

PRODUCT FEATURES

CONSTRUCTION

- 12MM ARMOR P1201 LAMINATED PANELS WITH GLOSS BLACK HONEYCOMB EXTERIOR
- PENN ELCOM HARDWARE
- ALUMINIUM EXTRUSIONS
- STEEL BALL CORNERS
- 2X MEDIUM RECESSED HANDLES
- HIGH DENSITY FOAM PROTECTION

FEATURES

- DEDICATED SPACE FOR YAMAHA TF1 16 CHANNEL DIGITAL AUDIO MIXER
- LIFT- OFF LID DESIGN
- CUSTOM FOAM INTERIOR FOR SECURE MIXER POSITIONING
- PROTECTION FOR KNOBS, FADERS, DISPLAYS AND INPUTS
- MINIMISES MOVEMENT OF EQUIPMENT DURING TRANSPORTATION
- SUITABLE FOR TRANSPORTATION AND STORAGE
- CUSTOM ENGRAVING ON FRONT AND BACK
- DESIGN SPECIFICATIONS
- HEAVY DUTY ROAD CASE CONSTRUCTION
- DESIGNED FOR TOURING, LIVE SOUND AND EVENT APPLICATIONS
- ROBUST HANDLES FOR EASY LIFTING AND TRANSPORTATION
- PROTECTS AGAINST IMPACTS, SCRATCHES AND MOISTURE

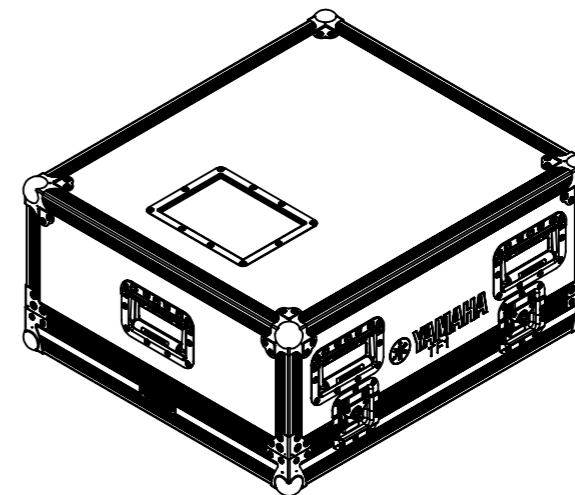
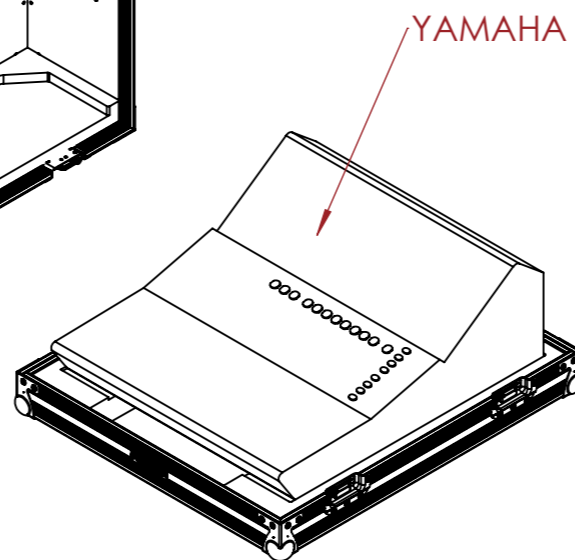
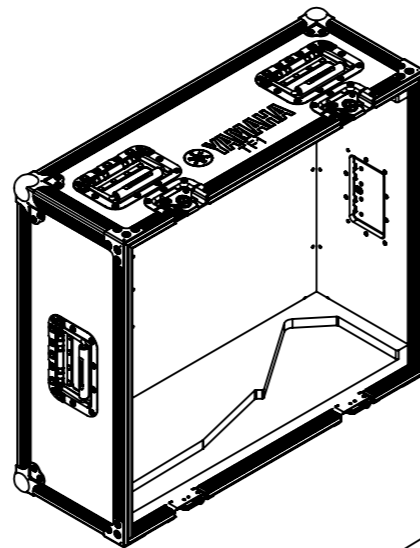

NOTES:

UNLESS SPECIFIED IN THE DRAWING, ALL PRODUCTS DISPLAYED IN THIS DRAWING OTHER THAN THE CASE ITSELF IS NOT PART OF OUR PRODUCT OFFERING.

ESTIMATED WEIGHT (CASE ONLY):

19.10 KG

ITEM CODE:

MIXR-YMH-TF1

DRAWN BY:

HA

CHECKED BY:

AS

SCALE:

NTS



MAIL : sales@armorcases.com.au
 WEB : www.armorcases.com.au