

# PRODUCT FEATURES

## CONSTRUCTION

- 9MM BIRCH VENEER PLYWOOD WITH HPL EXTERIOR FACE AND PVC INTERIOR FACE
- PENN ELCOM HARDWARE

## INSTALLED EQUIPMENT (INCLUDED)

- 10X LARGE RECESSED HANDLES
- 2X SLIM RECESSED HANDLES
- 10X LARGE LATCHES
- 1X LARGE LABEL DISH
- 2X CORNER HANDLES

## FEATURES

- 3 PIECE MIXER CASE WITH DOGBOX

## KEY MEASUREMENTS

- 200mm DEEP DOGBOX

## DESIGN SPECIFICATIONS

- 2U RACK UNDER THE MIXER

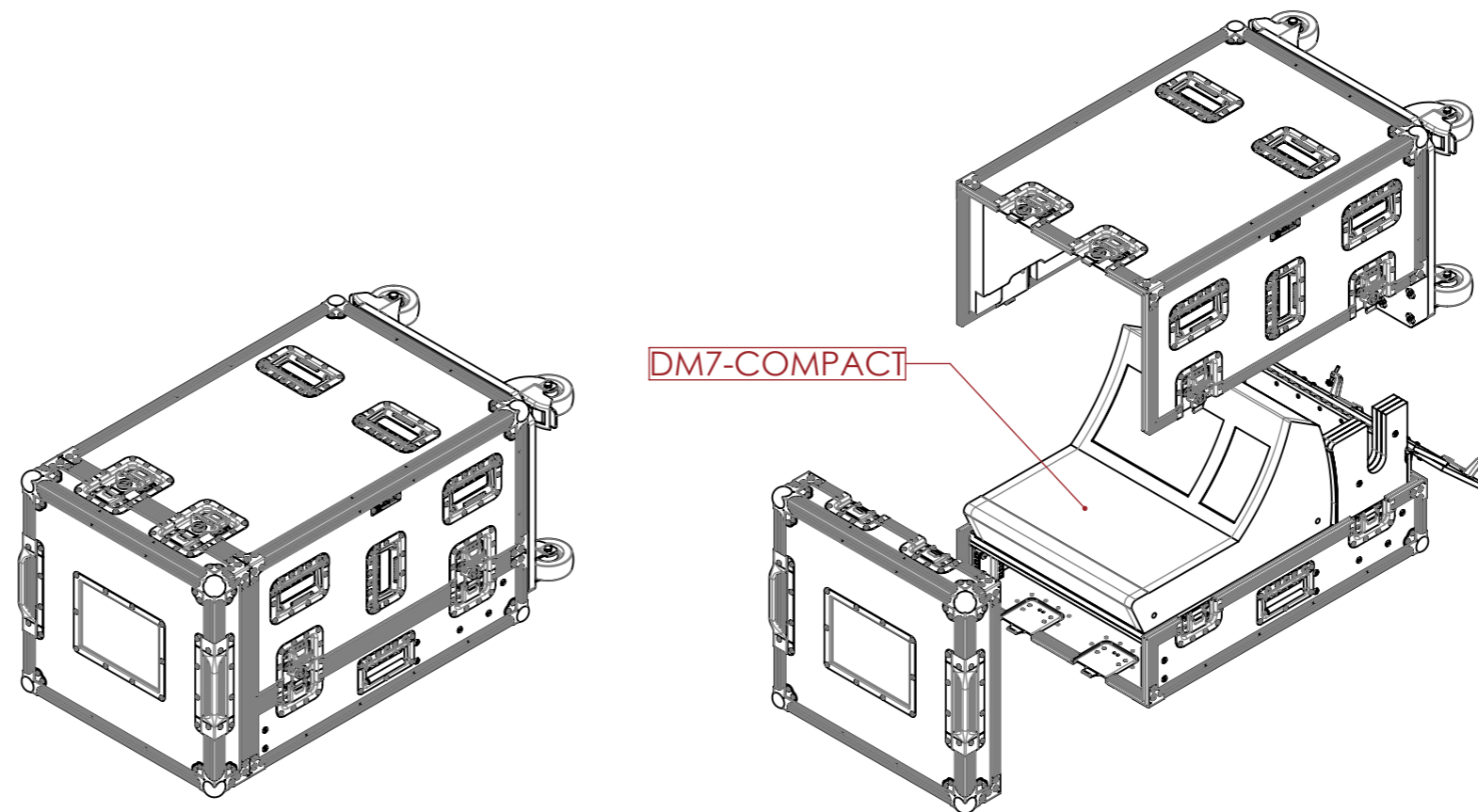
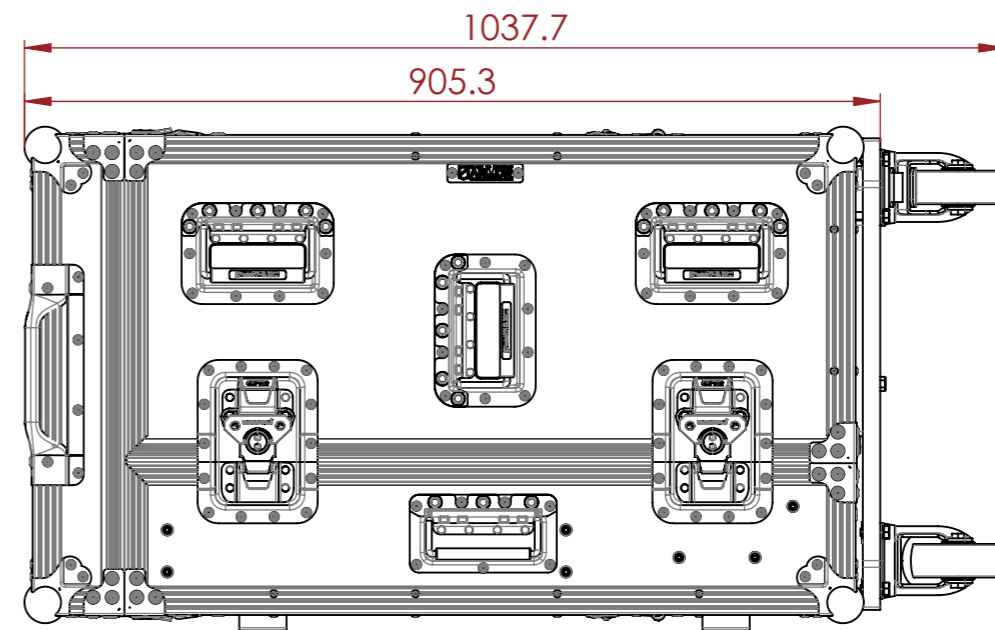
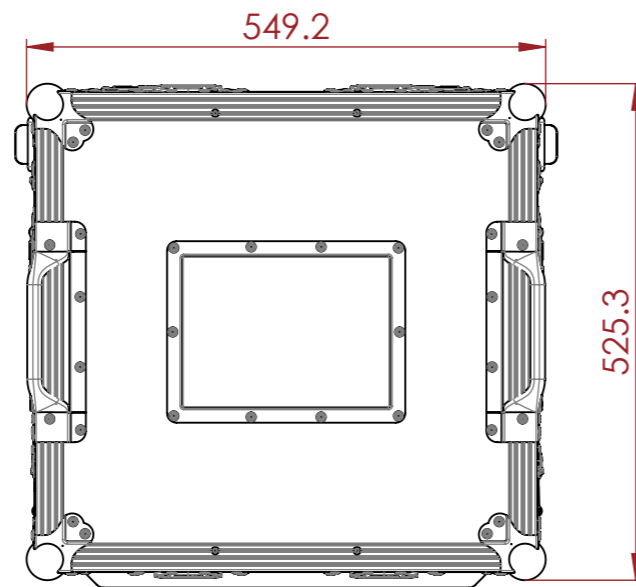

NOTES:  
UNLESS SPECIFIED IN THE DRAWING,  
ALL PRODUCTS DISPLAYED IN THIS  
DRAWING OTHER THAN THE CASE  
ITSELF IS NOT PART OF OUR PRODUCT  
OFFERING.

ESTIMATED WEIGHT (CASE ONLY):

46.5 KG

ITEM CODE:

MIXR-YMH-DM7C-3P

DRAWN BY:

HA

CHECKED BY:

AS

SCALE:

NTS



MAIL : [sales@armorcases.com.au](mailto:sales@armorcases.com.au)  
WEB : [www.armorcases.com.au](http://www.armorcases.com.au)