

NOTES:
UNLESS SPECIFIED IN THE DRAWING,
ALL PRODUCTS DISPLAYED IN THIS
DRAWING OTHER THAN THE CASE
ITSELF IS NOT PART OF OUR PRODUCT
OFFERING.

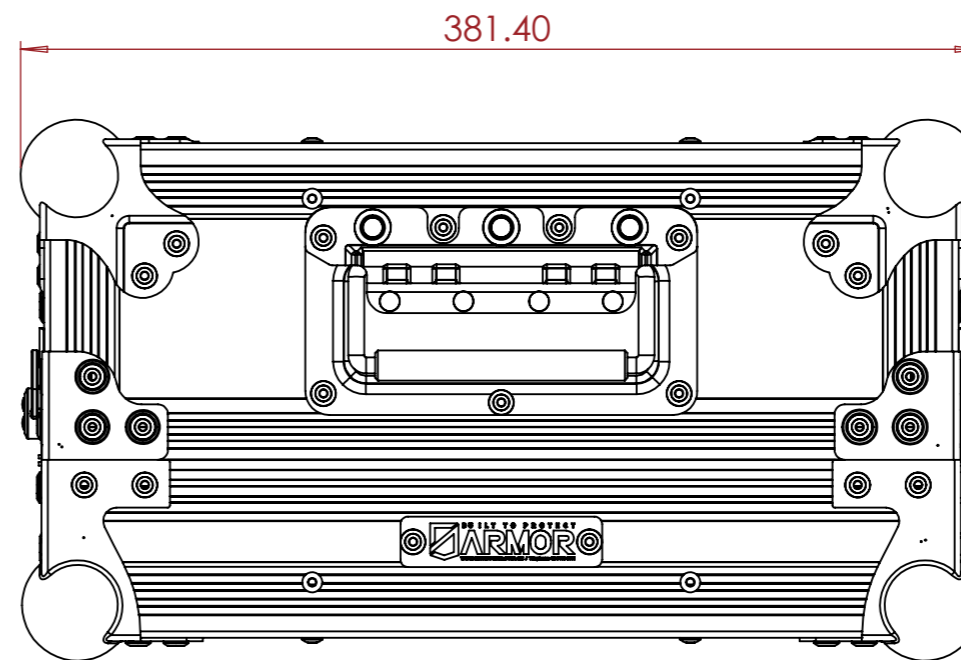
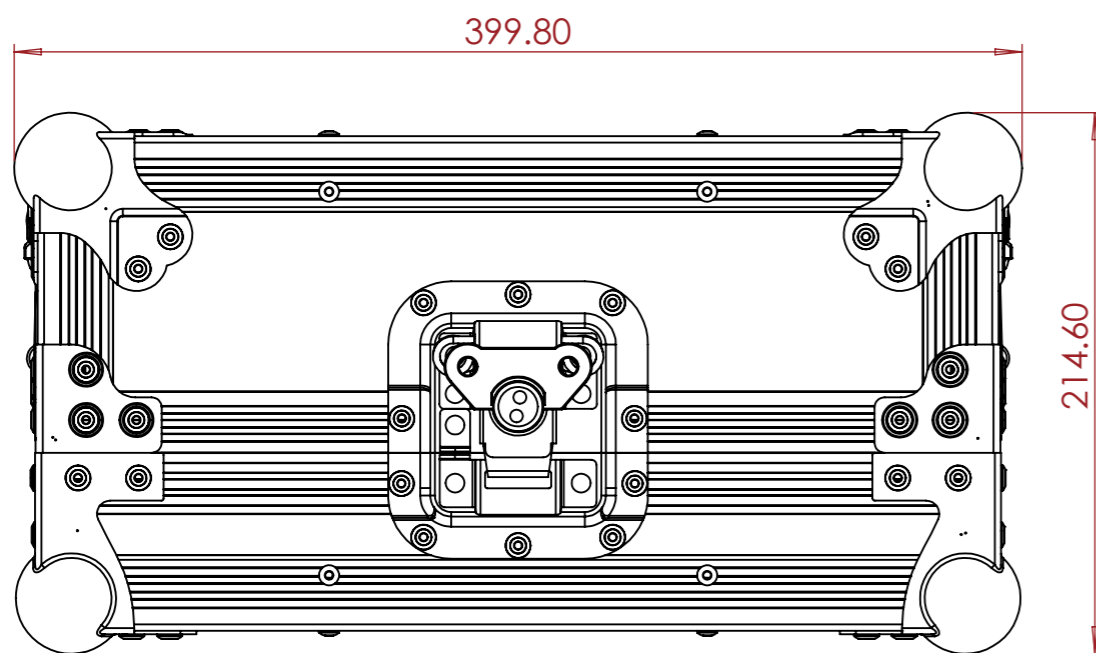

PRODUCT FEATURES

CONSTRUCTION

- 9MM ARMOR P901 LAMINATED PANELS WITH GLOSS BLACK HONEYCOMB EXTERIOR
- PENN ELCOM HARDWARE
- 2X MEDIUM RECESSED HANDLES
- HIGH DENSITY FOAM PROTECTION
- REINFORCED BALL CORNERS

FEATURES

- DEDICATED SPACE FOR ALLEN & HEATH ZEDI10 MIXER
- LIFT OFF LID DESIGN
- CUSTOM FOAM INTERIOR FOR SECURE MIXER POSITIONING
- CUSTOM ENGRAVING ON FRONT AND BACK
- PROTECTION AGAINST TRANSPORTATION DAMAGE

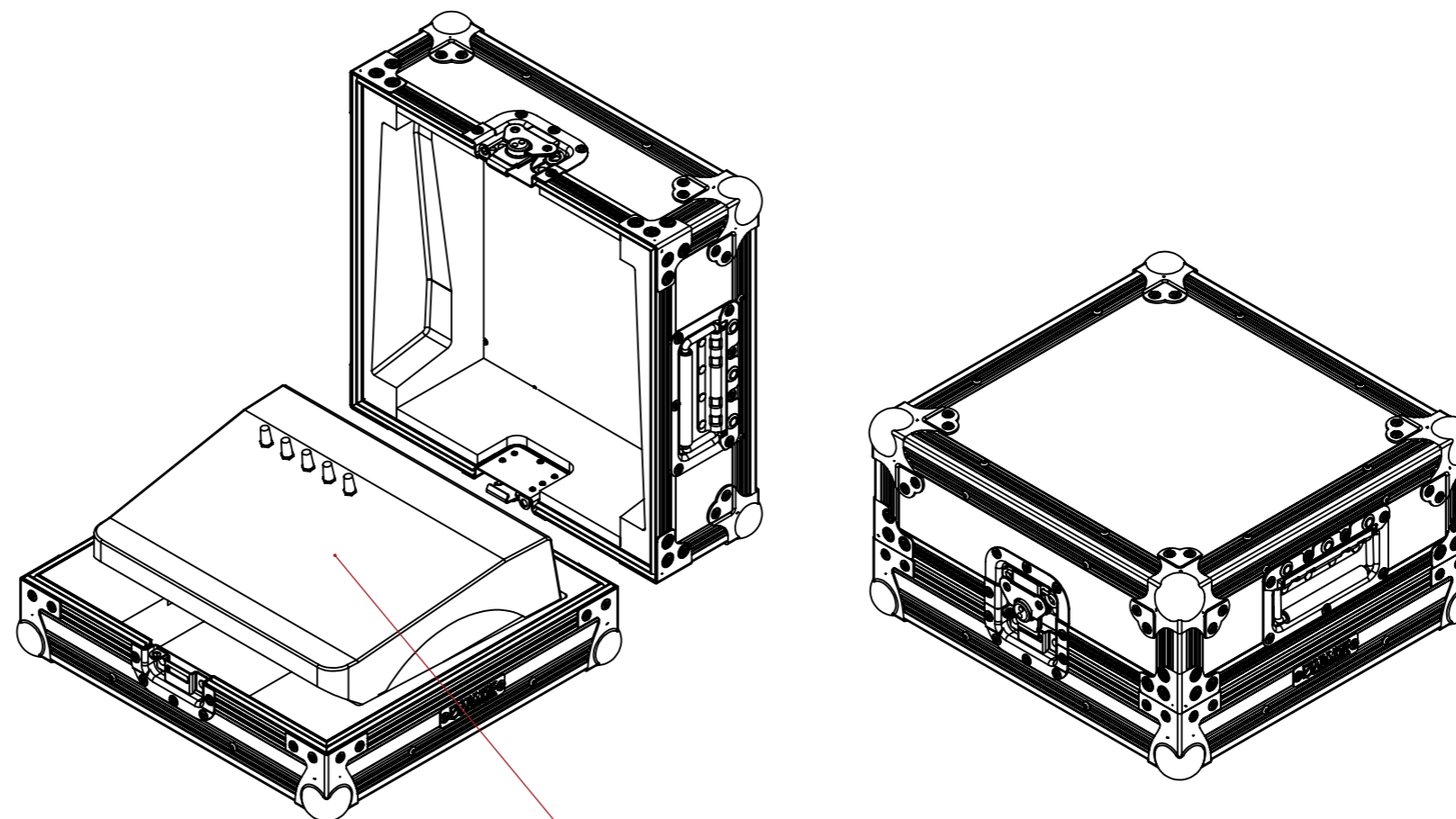

ALLEN & HEATH ZEDI10 MIXER

ESTIMATED WEIGHT (CASE ONLY):

6.6kg

ITEM CODE:

MIXR-AH-ZEDI10 Case

DRAWN BY:

RP

CHECKED BY:

AS

SCALE:

NTS



MAIL : sales@armorcases.com.au
WEB : www.armorcases.com.au