

# PRODUCT FEATURES

## CONSTRUCTION

- 12MM BIRCH VENEER PLYWOOD WITH HPL EXTERIOR FACE AND PVC INTERIOR FACE
- PENN ELCOM HARDWARE

## INSTALLED EQUIPMENT (INCLUDED)

- EVA 38 FOAM PROTECTION
- 2X RECESSED HANDLES
- 4X MEDIUM LATCHES
- 1X LABEL DISH

## FEATURES

- LIFT-OFF LID DESIGN
- ENGRAVING ON TOP OF LID

## KEY MEASUREMENTS

- N/A

## DESIGN SPECIFICATIONS

- DEDICATED SPACE FOR STORING 1X ALLEN & HEATH SQ7
- GENERAL STORAGE FOR ACCESSORIES UNDER THE MIXER

NOTES:  
UNLESS SPECIFIED IN THE DRAWING,  
ALL PRODUCTS DISPLAYED IN THIS  
DRAWING OTHER THAN THE CASE  
ITSELF IS NOT PART OF OUR PRODUCT  
OFFERING.

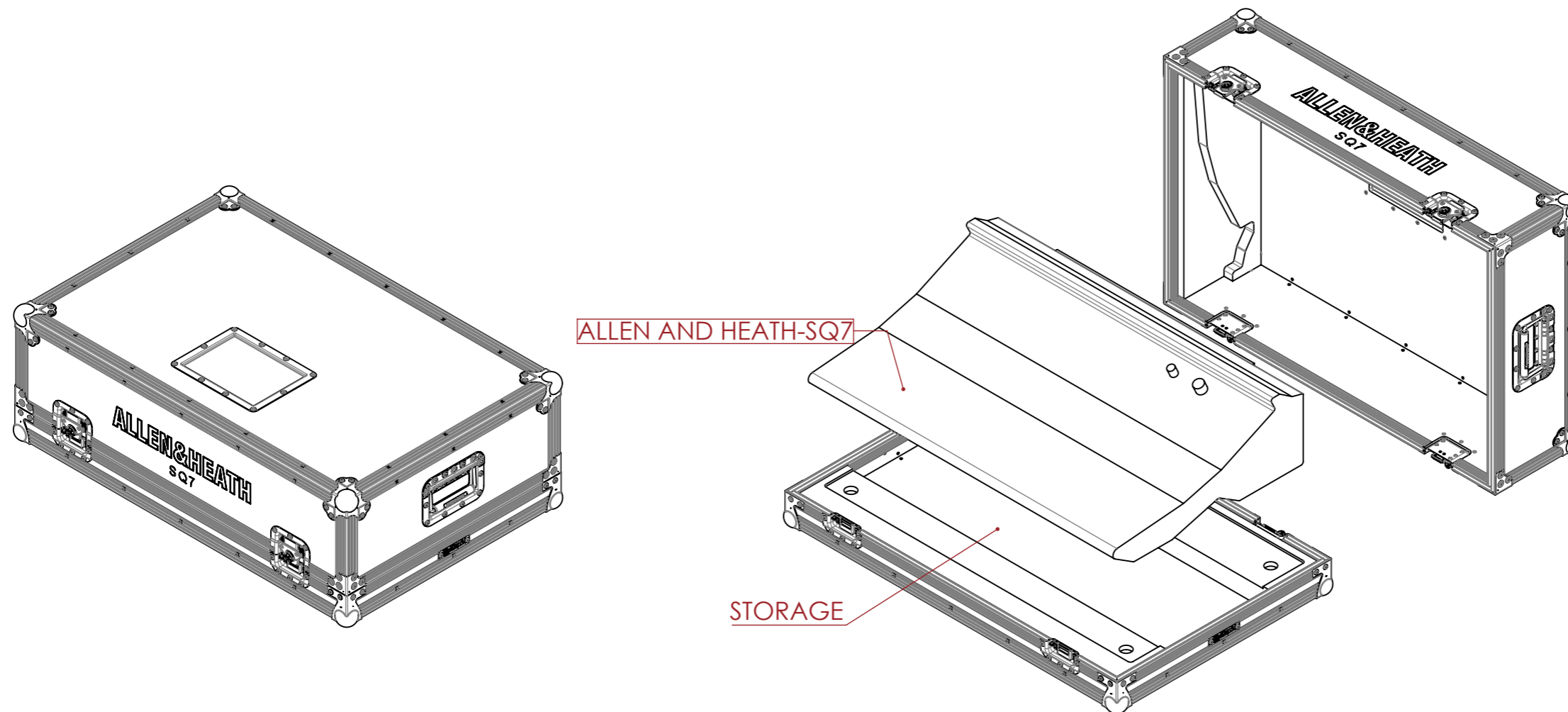
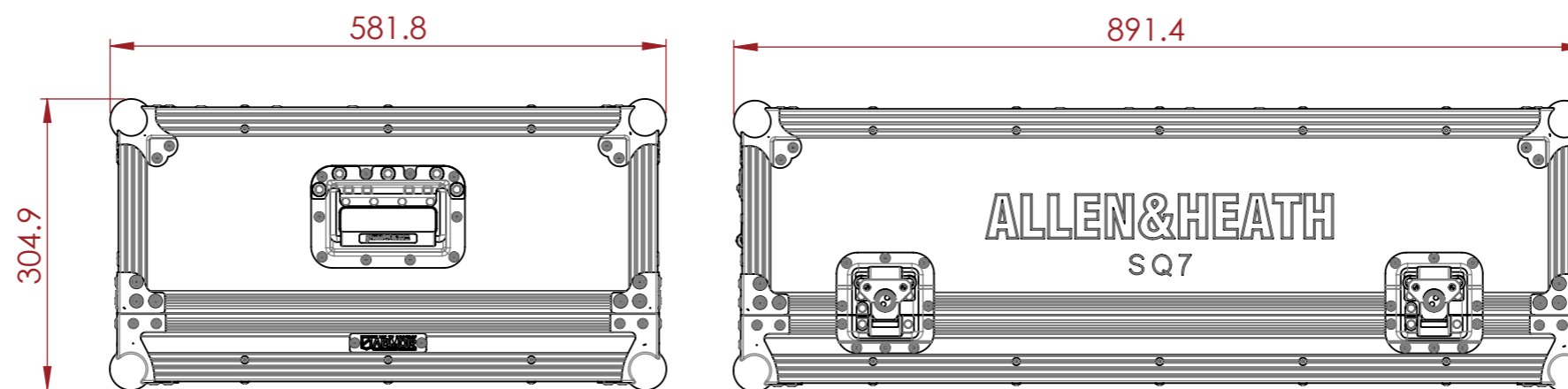

ESTIMATED WEIGHT (CASE ONLY):  
21.51 KG

ITEM CODE:  
MIXR-AH-SQ7

DRAWN BY: HA      CHECKED BY: AS

SCALE:  
NTS



MAIL : [sales@armorcases.com.au](mailto:sales@armorcases.com.au)  
WEB : [www.armorcases.com.au](http://www.armorcases.com.au)