

PRODUCT FEATURES

CONSTRUCTION

- 12MM BIRCH VENEER PLYWOOD WITH HPL EXTERIOR FACE AND PVC INTERIOR FACE
- PENN ELCOM HARDWARE

INSTALLED EQUIPMENT (INCLUDED)

- EVA 38 FOAM PROTECTION
- 2X RECESSED HANDLES
- 4X MEDIUM LATCHES

FEATURES

- DEDICATED ACCESSORY STORAGE COMPARTMENT FOR CABLES, ADAPTERS, AND TOOLS
- LIFT-OFF LID DESIGN

KEY MEASUREMENTS

- N/A

DESIGN SPECIFICATIONS

- DEDICATED SPACE FOR STORING 1X ALLEN & HEATH SQ6

NOTES:
UNLESS SPECIFIED IN THE DRAWING,
ALL PRODUCTS DISPLAYED IN THIS
DRAWING OTHER THAN THE CASE
ITSELF IS NOT PART OF OUR PRODUCT
OFFERING.

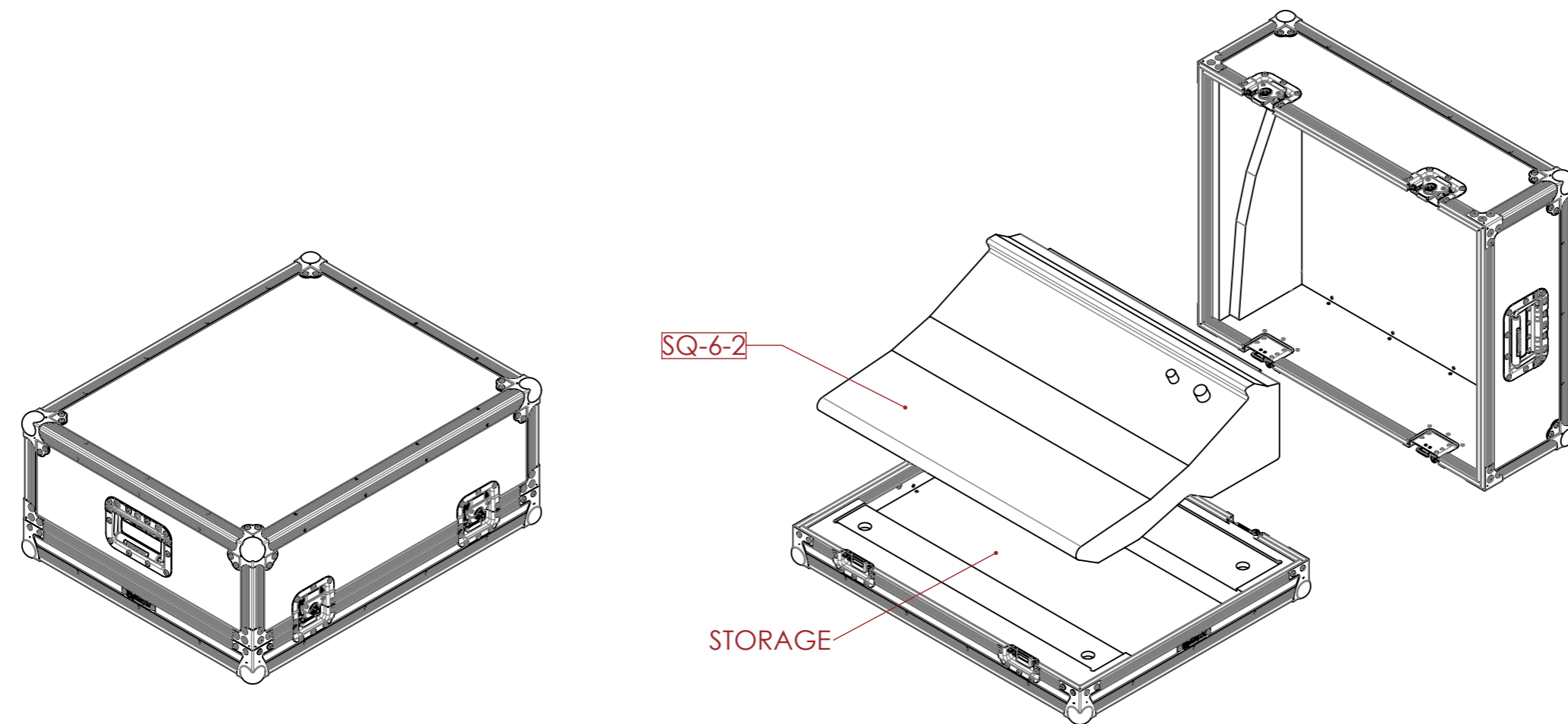
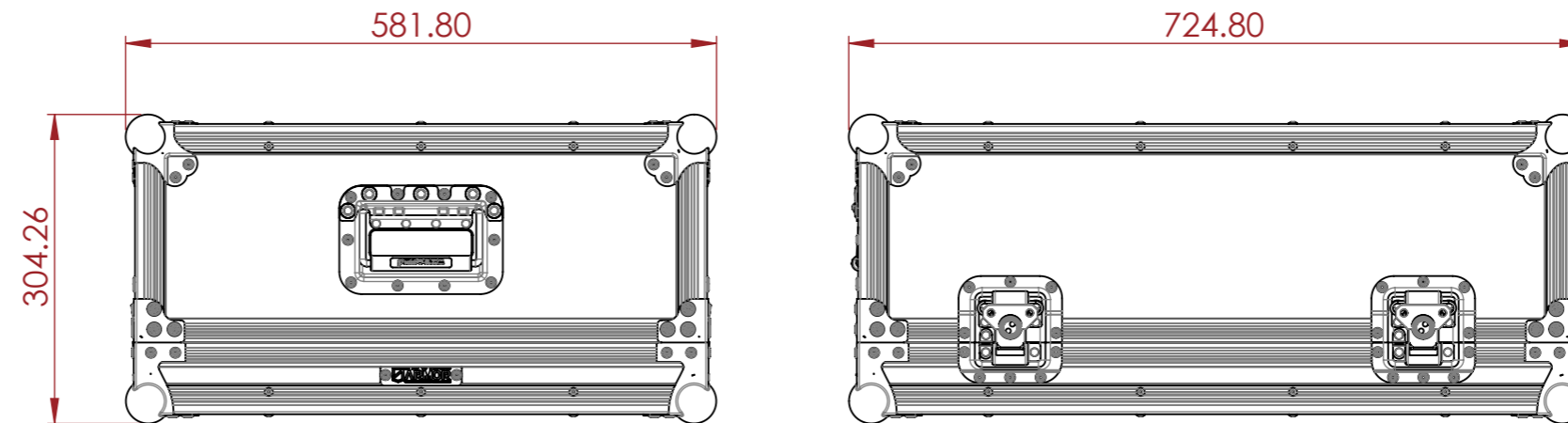

ESTIMATED WEIGHT (CASE ONLY):

17.30 KG

ITEM CODE:

MIXR-AH-SQ6

DRAWN BY:

K.I

CHECKED BY:

AS

SCALE:

NTS



MAIL : sales@armorcases.com.au
WEB : www.armorcases.com.au