

PRODUCT FEATURES

CONSTRUCTION

- 12MM BIRCH VENEER PLYWOOD WITH HPL EXTERIOR FACE AND PVC INTERIOR FACE
- PENN ELCOM HARDWARE

INSTALLED EQUIPMENT (INCLUDED)

- 10X LARGE RECESSED HANDLES
- 2X SLIM RECESSED HANDLES
- 10X LARGE LATCHES
- 1X MEDIUM LABEL DISH
- 4X CASTORS 2X BRAKED

FEATURES

- LIFT-OFF LIDS DESIGN WITH HANDLES

KEY MEASUREMENTS

- HEIGHT OF STORAGE UNDER THE MIXER - 50MM

DESIGN SPECIFICATIONS

- DEDICATED SPACE FOR STORING 1X ALLEN & HEATH C3500
- 3 PIECE DESIGN WITH CASTORS

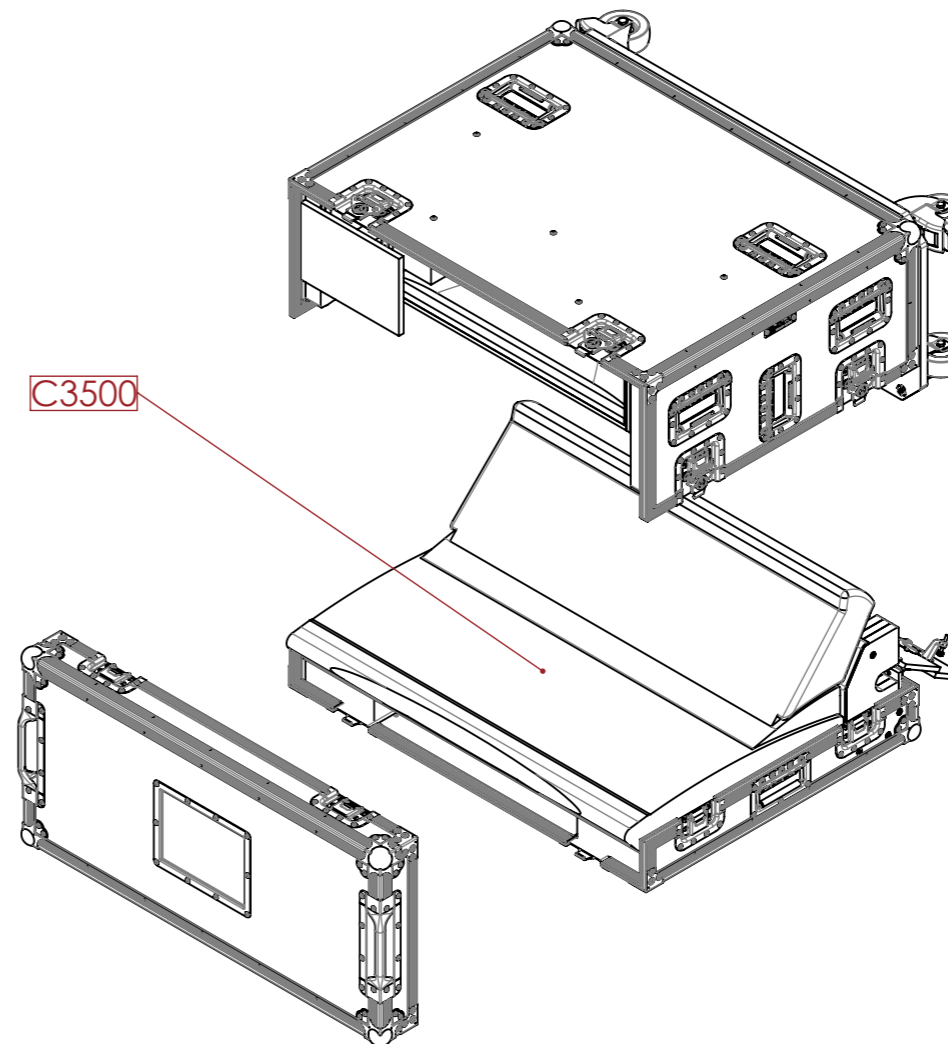
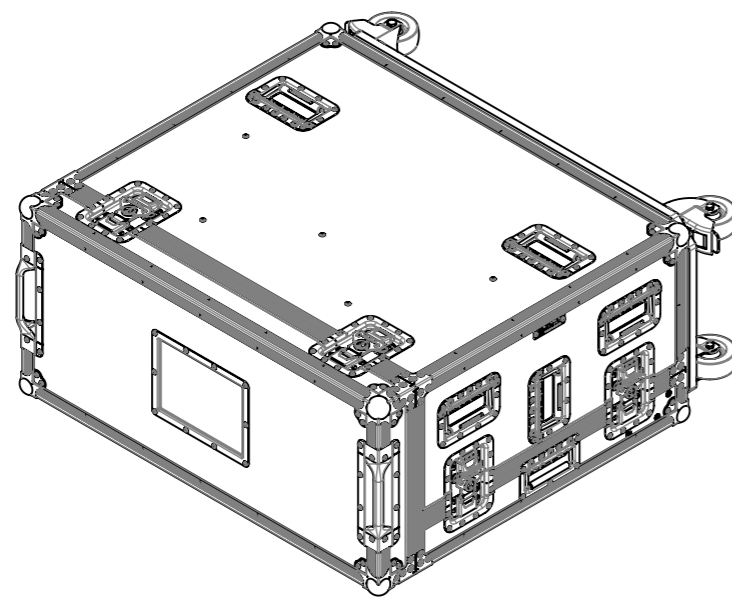
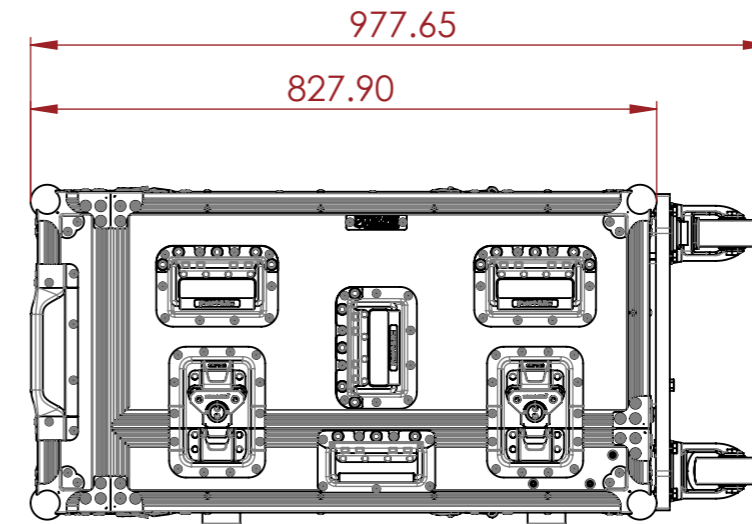
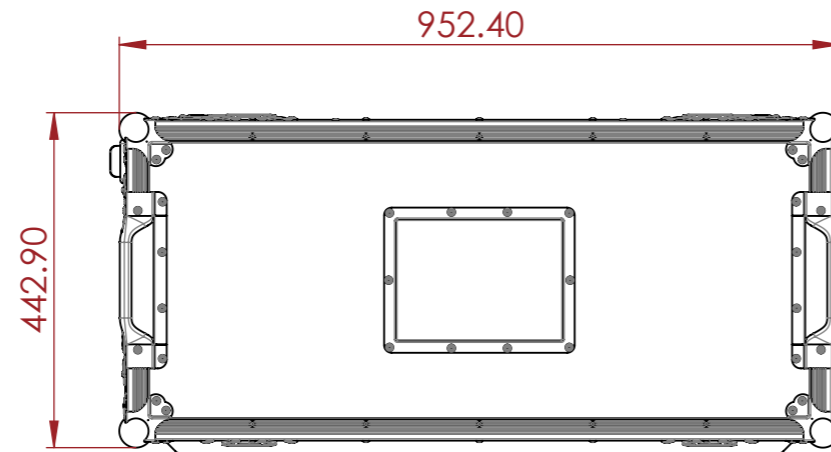

NOTES:

UNLESS SPECIFIED IN THE DRAWING, ALL PRODUCTS DISPLAYED IN THIS DRAWING OTHER THAN THE CASE ITSELF IS NOT PART OF OUR PRODUCT OFFERING.

ESTIMATED WEIGHT (CASE ONLY):

50.75 KG

ITEM CODE:

MIXR-AH-C3500

DRAWN BY:

RP

CHECKED BY:

AS

SCALE:

NTS



MAIL : sales@armorcases.com.au
WEB : www.armorcases.com.au