

# PRODUCT FEATURES

## CONSTRUCTION

- 12MM BIRCH VENEER PLYWOOD WITH HPL EXTERIOR FACE AND PVC INTERIOR FACE
- PENN ELCOM HARDWARE

## INSTALLED EQUIPMENT (INCLUDED)

- 8X LARGE RECESSED HANDLES
- 6X MEDIUM LATCHES
- 2X LID STAYS
- 5X CASTORS 2X BRAKED
- 5X CASTOR DISHES

## FEATURES

- 2X POCKET STORAGE ON THE FRONT LID FOR STORING CLAMPS AND BRACKETS
- STACKABLE FOR COMPACT STORAGE

## KEY MEASUREMENTS

- N/A

## DESIGN SPECIFICATIONS

- DEDICATED SPACE FOR STORING 1X AYRTON EURUS PROFILE

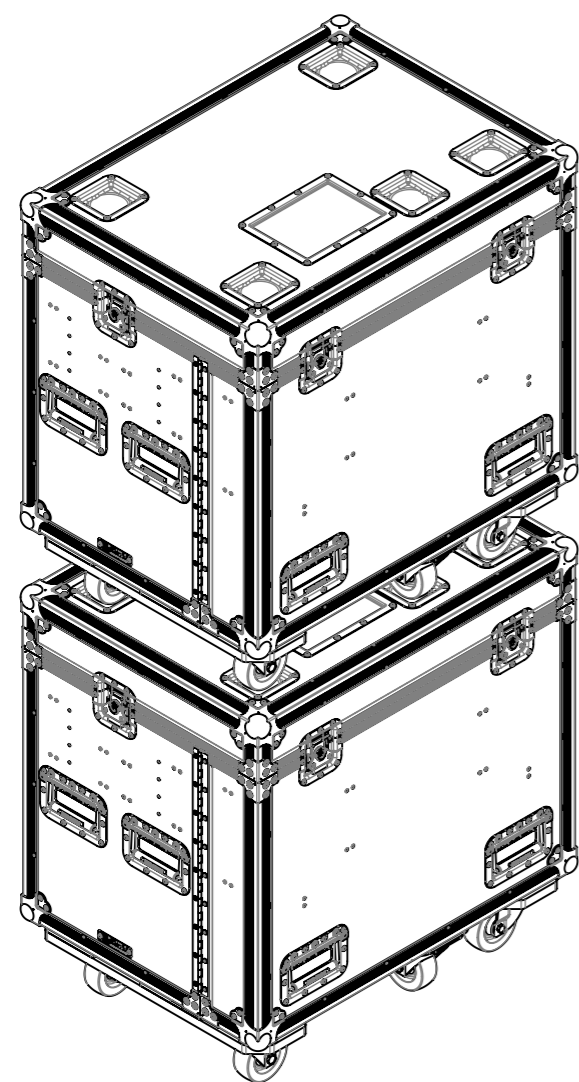
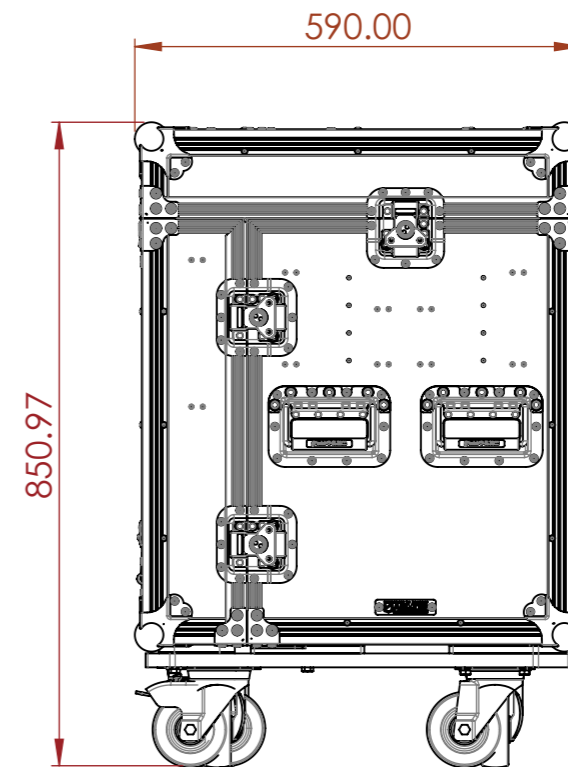
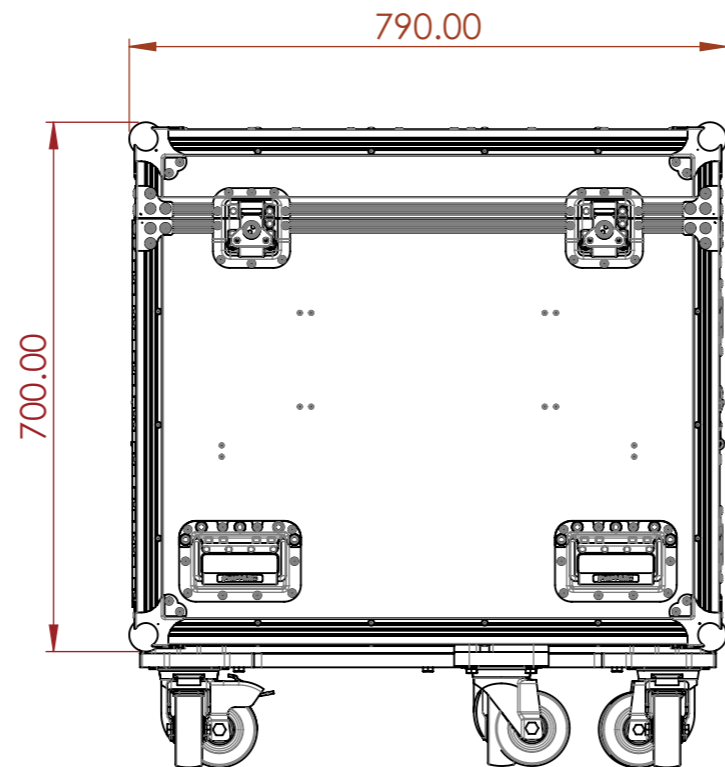

AYRTON EURUS PROFILE

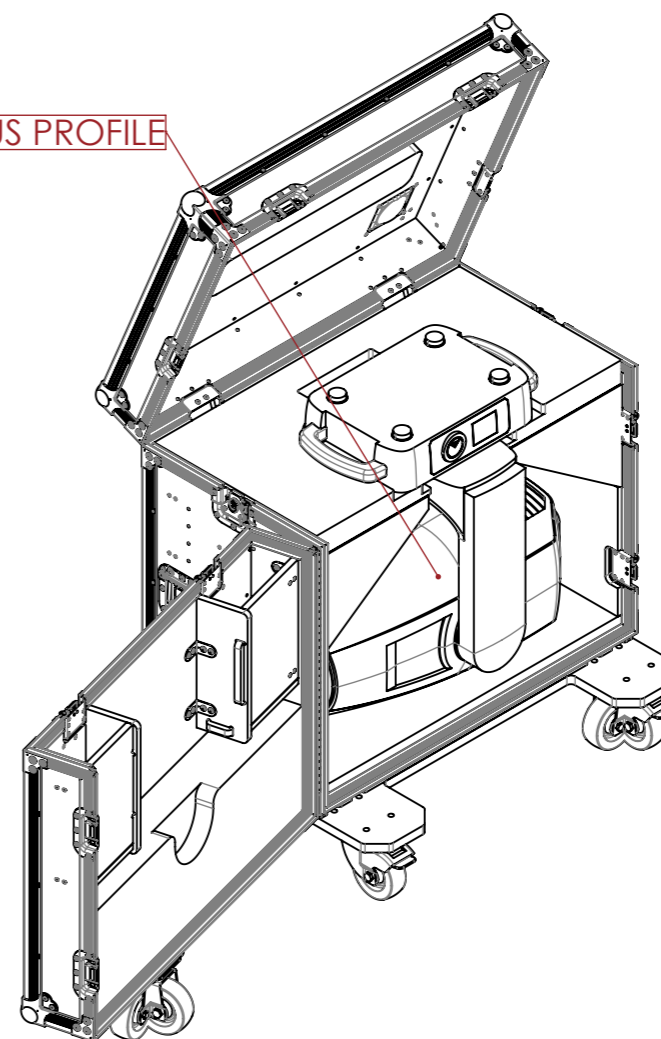

NOTES:  
UNLESS SPECIFIED IN THE DRAWING,  
ALL PRODUCTS DISPLAYED IN THIS  
DRAWING OTHER THAN THE CASE  
ITSELF IS NOT PART OF OUR PRODUCT  
OFFERING.

ESTIMATED WEIGHT (CASE ONLY):

61.52 KG

ITEM CODE:

LXMH-AYTN-EURUS

DRAWN BY:

HA

CHECKED BY:

AS

SCALE:

NTS



MAIL : [sales@armorcases.com.au](mailto:sales@armorcases.com.au)  
WEB : [www.armorcases.com.au](http://www.armorcases.com.au)