

PRODUCT FEATURES

CONSTRUCTION

- 7MM POLYPROPYLENE HONEYCOMB PLASTIC PANEL
- ARMOR HARDWARE

INSTALLED EQUIPMENT (INCLUDED)

- 1X RECESSED HANDLE
- 2X EDGE HANDLES
- 2X LATCHES
- 3X LID STAYS

FEATURES

- HINGED LID DESIGN

KEY MEASUREMENTS

- N/A

DESIGN SPECIFICATIONS

- DEDICATED SPACE FOR STORING 2X LENOVO L27M-30 MONITORS

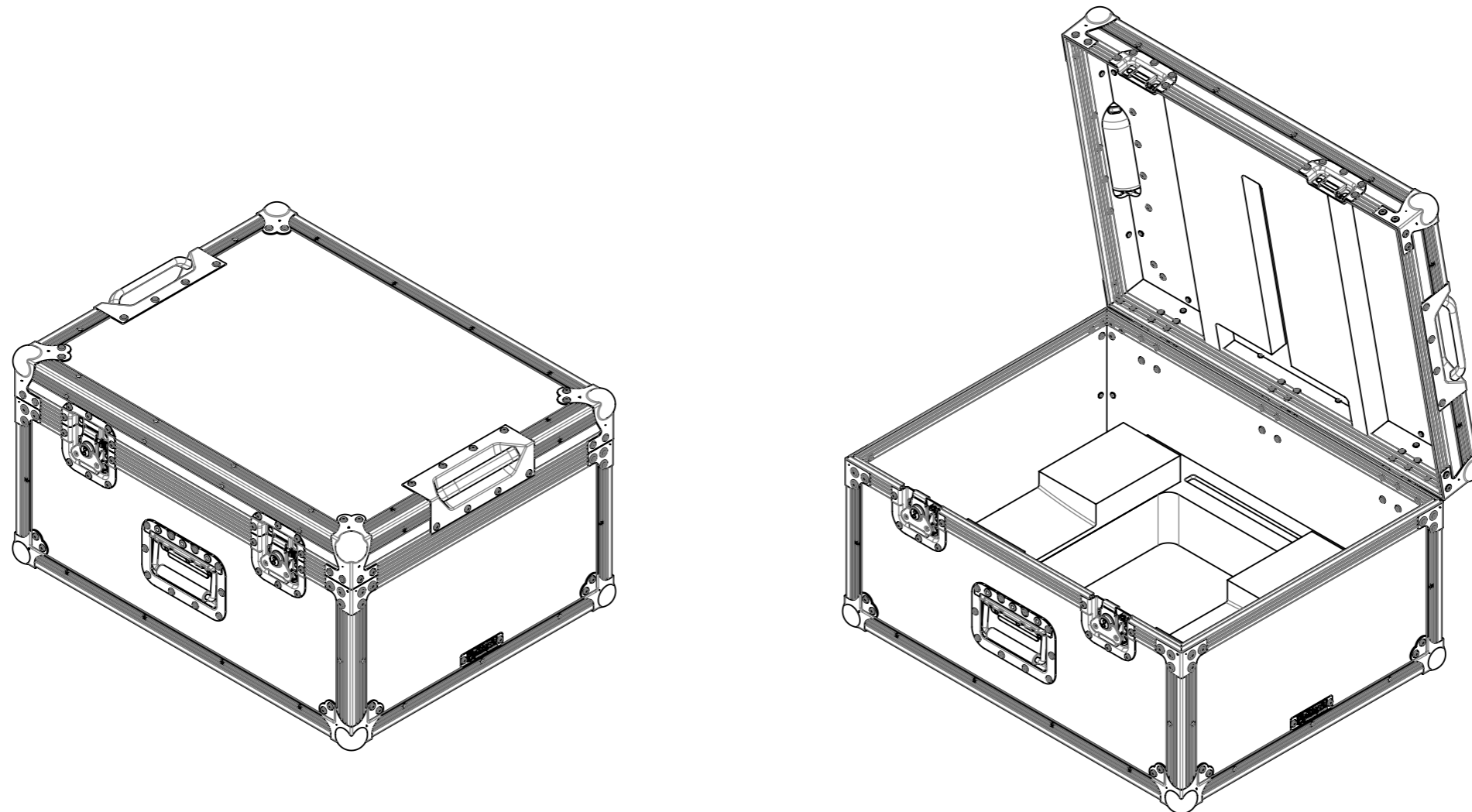
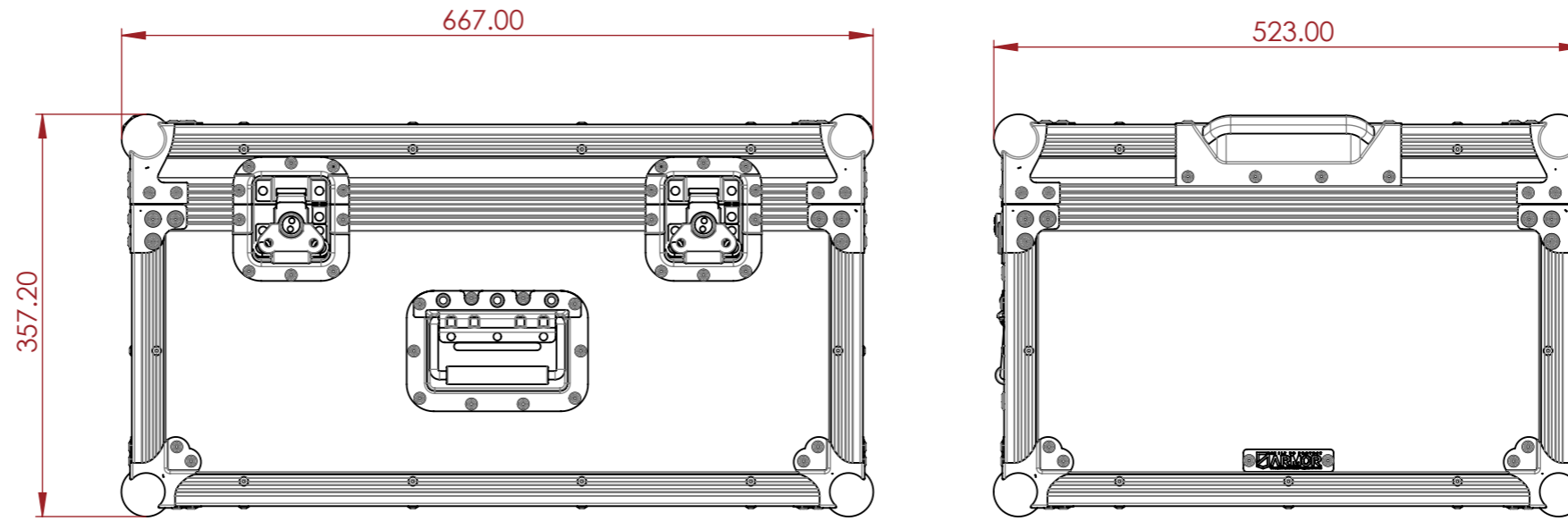

NOTES:

UNLESS SPECIFIED IN THE DRAWING, ALL PRODUCTS DISPLAYED IN THIS DRAWING OTHER THAN THE CASE ITSELF IS NOT PART OF OUR PRODUCT OFFERING.

ESTIMATED WEIGHT (CASE ONLY):

8.6 KG

ITEM CODE:

DISP-LENO-L27M30-01

DRAWN BY:

RP

CHECKED BY:

AS

SCALE:

NTS



MAIL : sales@armorcases.com.au
WEB : www.armorcases.com.au