

PRODUCT FEATURES

CONSTRUCTION

- 12MM BIRCH VENEER PLYWOOD WITH HPL EXTERIOR FACE AND PVC INTERIOR FACE
- PENN ELCOM HARDWARE

DIVIDERS & TRAY(NOT INCLUDED)

- DIVIDERS RKU: INST-CP1206-SDD , INST-CP1206-SDL , INST-CP1206-TDD , INST-CP1206-TDL
- TRAY RKU: INST-CP1206-TRY

INSTALLED EQUIPMENT (INCLUDED)

- 8X LARGE RECESSED HANDLES
- 2X LARGE LATCHES
- 2X LIDSTAYS
- 1X CORNER HANDLE ON THE LID
- 2X NON-BRAKED CASTORS
- 2X BRAKED CASTORS
- 4X CASTOR DISHES FOR THE EASE OF STACKING
- 1X LABEL DISH FOR THE EASE OF RECOGNITION

FEATURES

- ADJUSTABLE STORAGE COMPARTMENTS
- TRUCK FRIENDLY DIMENSIONS

DESIGN SPECIFICATIONS

- STACKABLE DESIGN

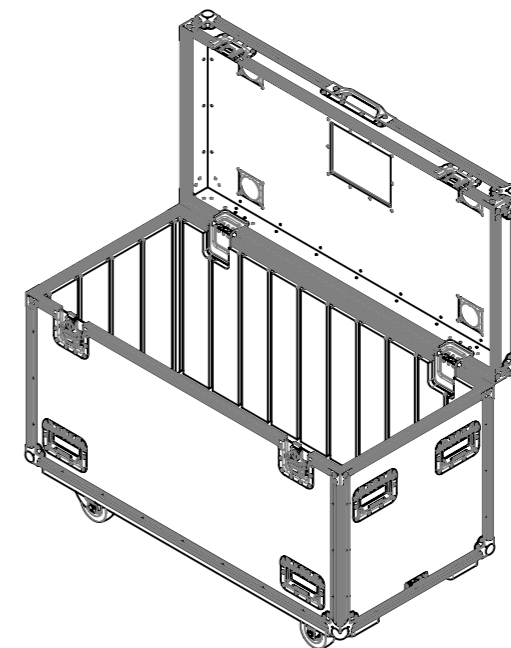
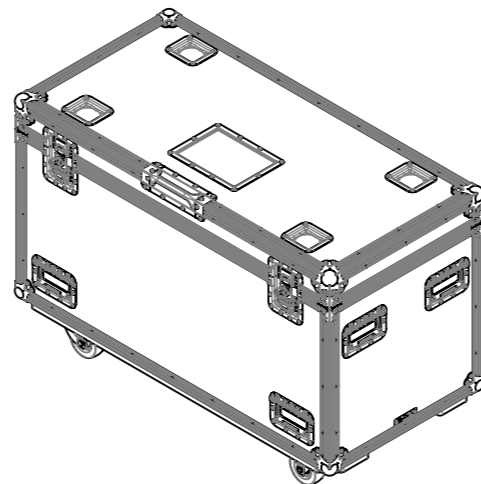
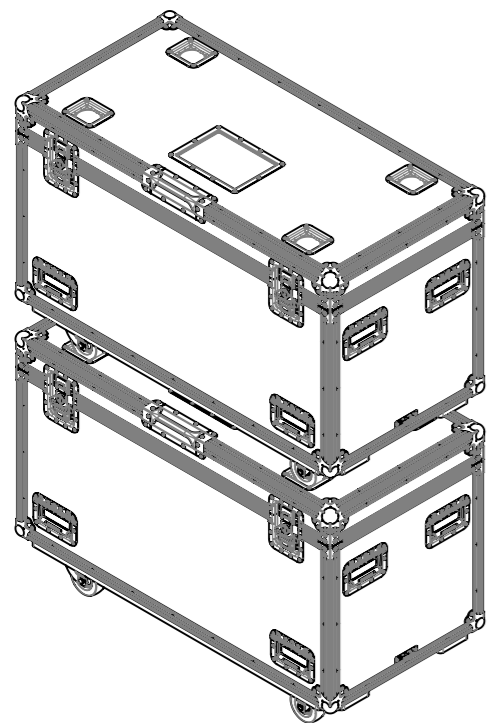
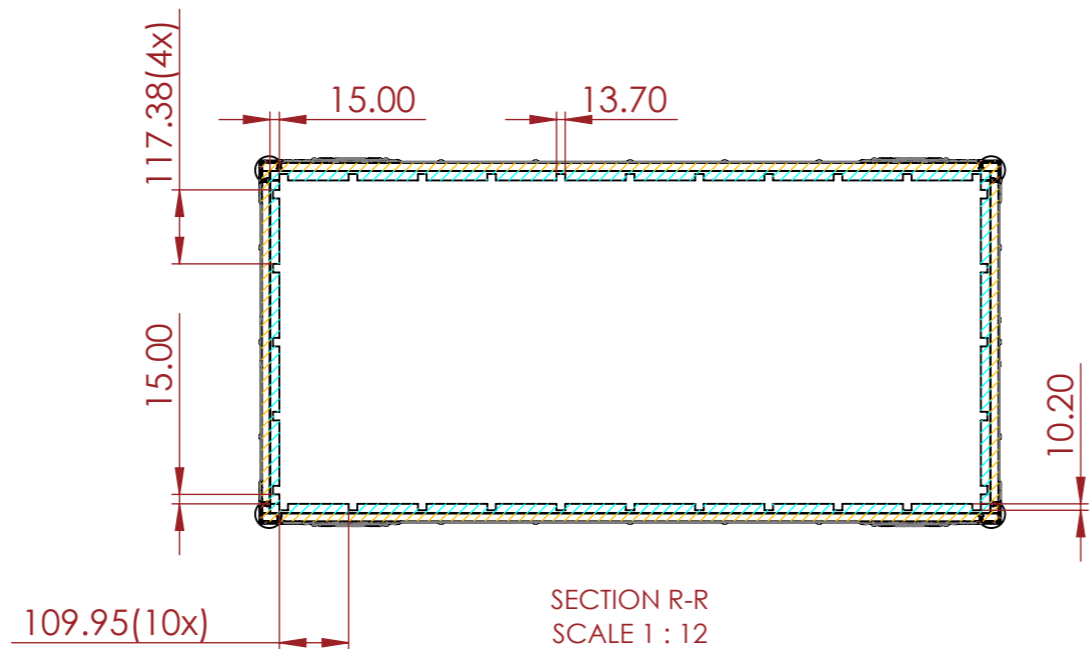
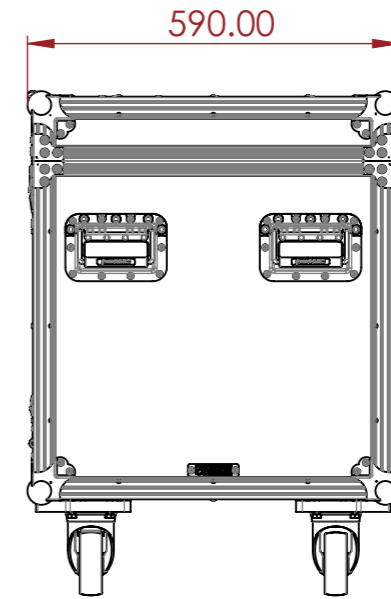
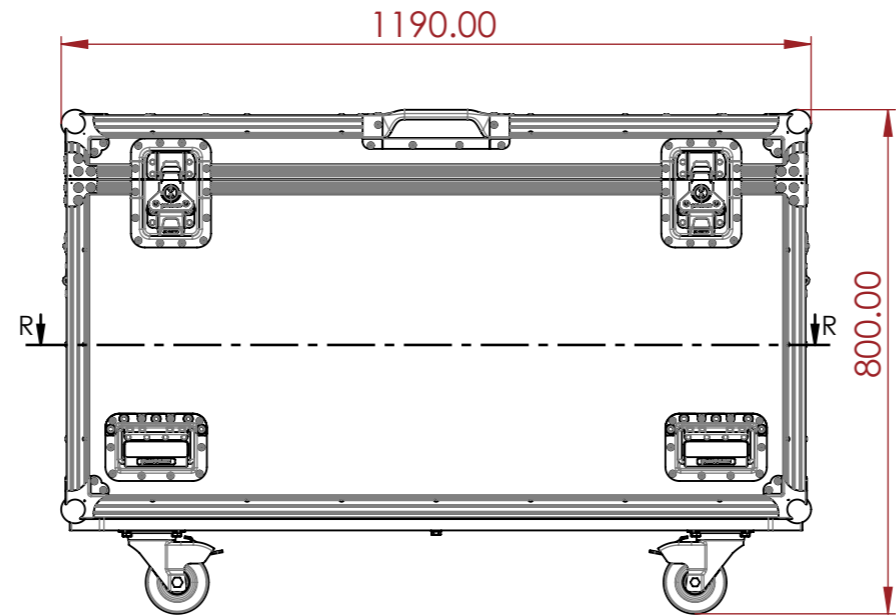

NOTES:
UNLESS SPECIFIED IN THE DRAWING,
ALL PRODUCTS DISPLAYED IN THIS
DRAWING OTHER THAN THE CASE
ITSELF IS NOT PART OF OUR PRODUCT
OFFERING.

ESTIMATED WEIGHT (CASE ONLY):

51.91 KG

ITEM CODE:

UTL-CP1206T

DRAWN BY:

K.I

CHECKED BY:

AS

SCALE:

NTS



MAIL : sales@armorcases.com.au
WEB : www.armorcases.com.au