

PRODUCT FEATURES

CONSTRUCTION

- 12MM BIRCH VENEER PLYWOOD WITH HPL EXTERIOR FACE AND PVC INTERIOR FACE
- PENN ELCOM HARDWARE

DIVIDERS & TRAY (NOT INCLUDED)

- DIVIDERR SKU: INST-CP1206-SDD , INST-CP1206-SDL

INSTALLED EQUIPMENT (INCLUDED)

- 8X LARGE RECESSED HANDLES
- 2X LARGE LATCHES
- 2X LIDSTAYS
- 1X CORNER HANDLE ON THE LID
- 2X NON-BRAKED CASTORS
- 2X BRAKED CASTORS
- 4X CASTOR DISHES FOR EASE OF STACKING
- 1X LABEL DISH FOR THE EASE OF RECOGNITION

FEATURES

- ADJUSTABLE STORAGE COMPARTMENTS
- TRUCK FRIENDLY DIMENSIONS

DESIGN SPECIFICATIONS

- STACKABLE DESIGN

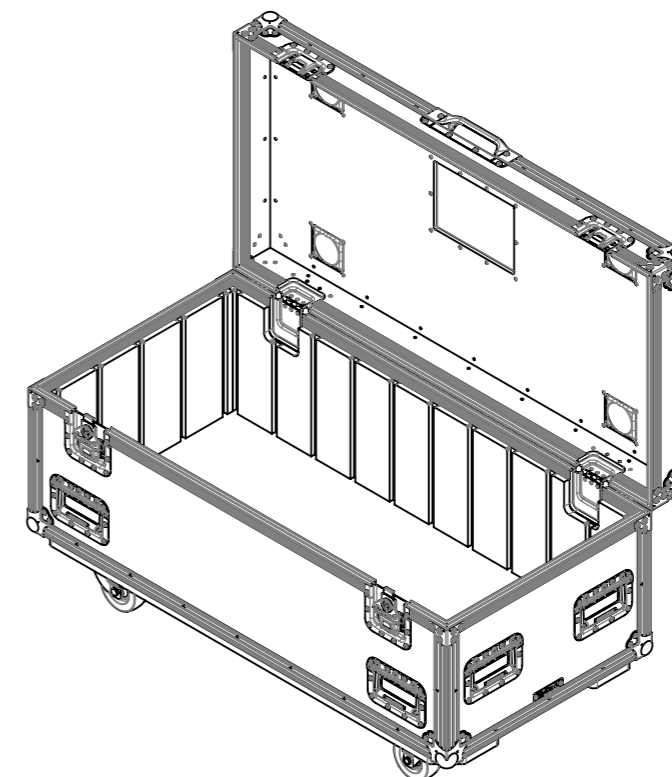
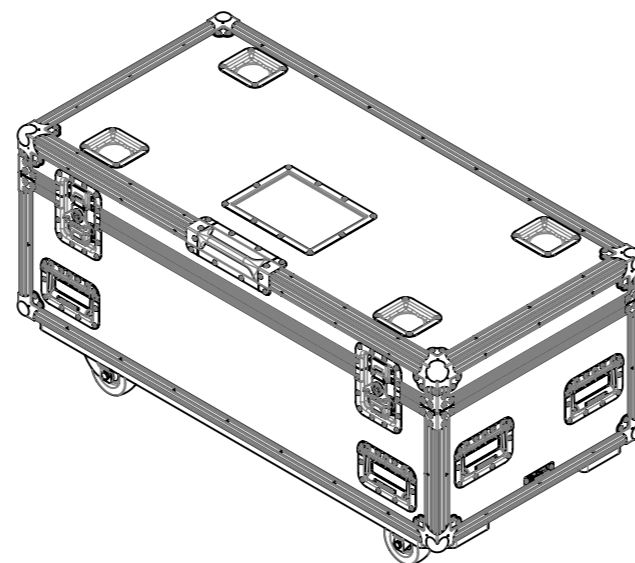
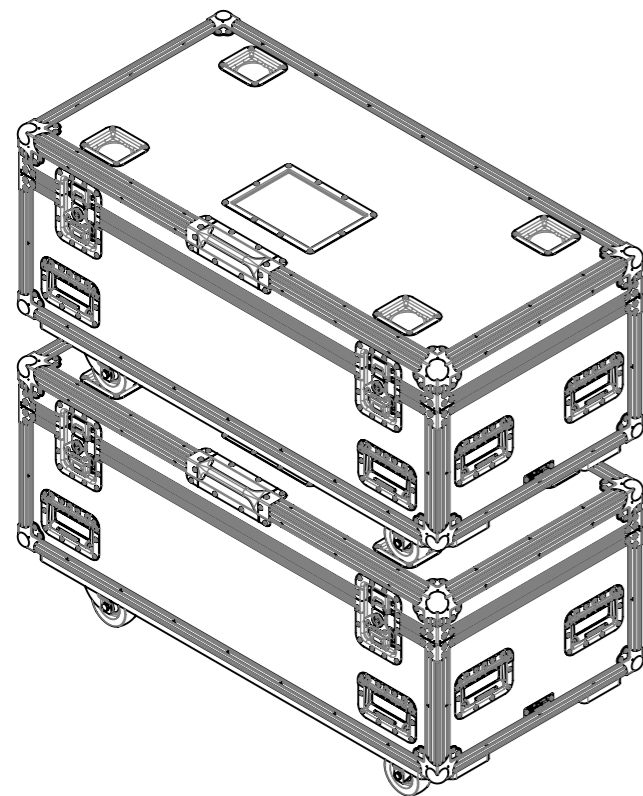
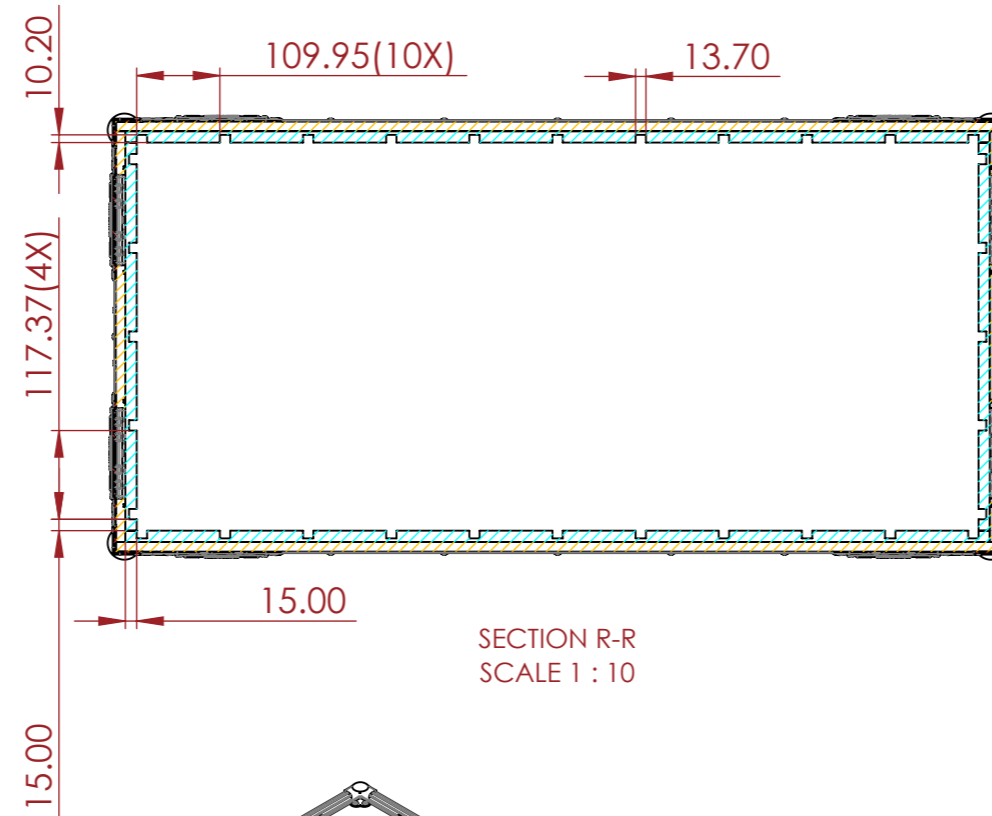
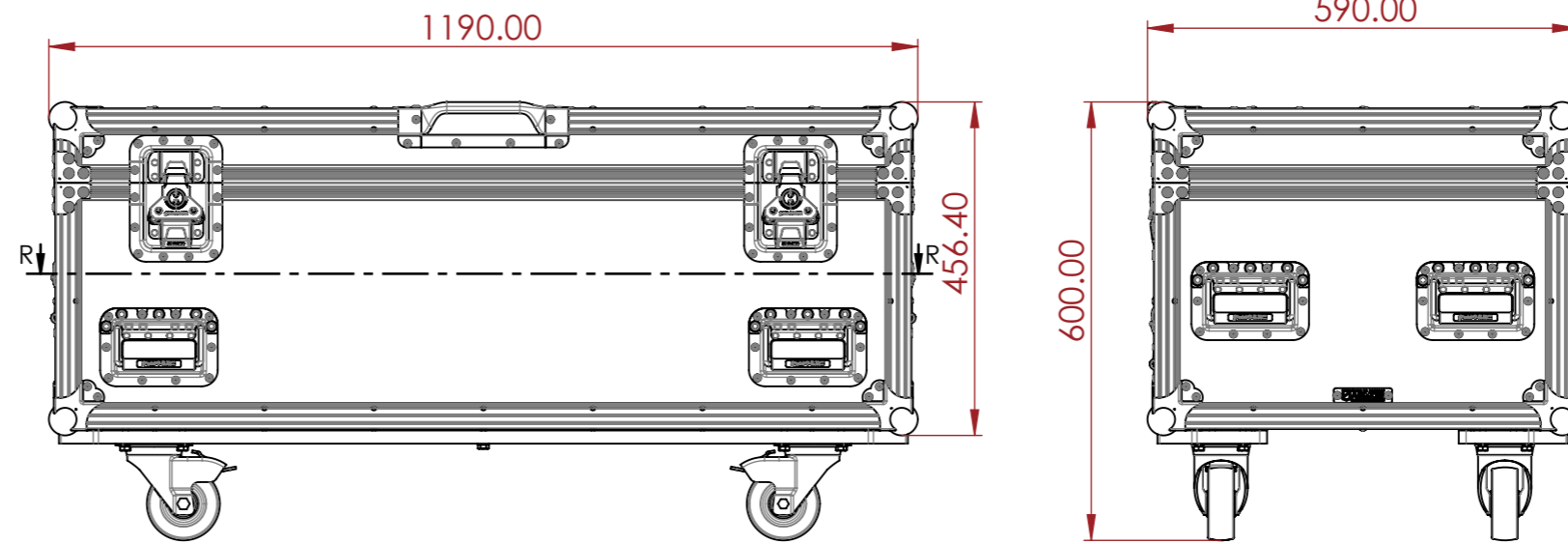

NOTES:

UNLESS SPECIFIED IN THE DRAWING, ALL PRODUCTS DISPLAYED IN THIS DRAWING OTHER THAN THE CASE ITSELF IS NOT PART OF OUR PRODUCT OFFERING.

ESTIMATED WEIGHT (CASE ONLY):

45.00 KG

ITEM CODE:

UTL-CP1206S

DRAWN BY:

K.I

CHECKED BY:

AS

SCALE:

NTS



MAIL : sales@armorcases.com.au
WEB : www.armorcases.com.au