

PRODUCT FEATURES

CONSTRUCTION

- 12MM BIRCH VENEER PLYWOOD WITH HPL EXTERIOR FACE AND PVC INTERIOR FACE
- PENN ELCOM HARDWARE

INSTALLED EQUIPMENT (INCLUDED)

- 1X MEDIUM LABEL DISH
- 8X LARGE RECESSED HANDLES
- 8X LARGE LATCHES
- 4X 100mm CASTORS 2X BRAKED
- 4X STEEL CASTOR DISHES

FEATURES

- HINGED LID DESIGN

KEY MEASUREMENTS

- N/A

DESIGN SPECIFICATIONS

- TRUCK FRIENDLY DIMENSIONS
- 2X STORAGE COMPARTMENTS FOR ACCESSORIES

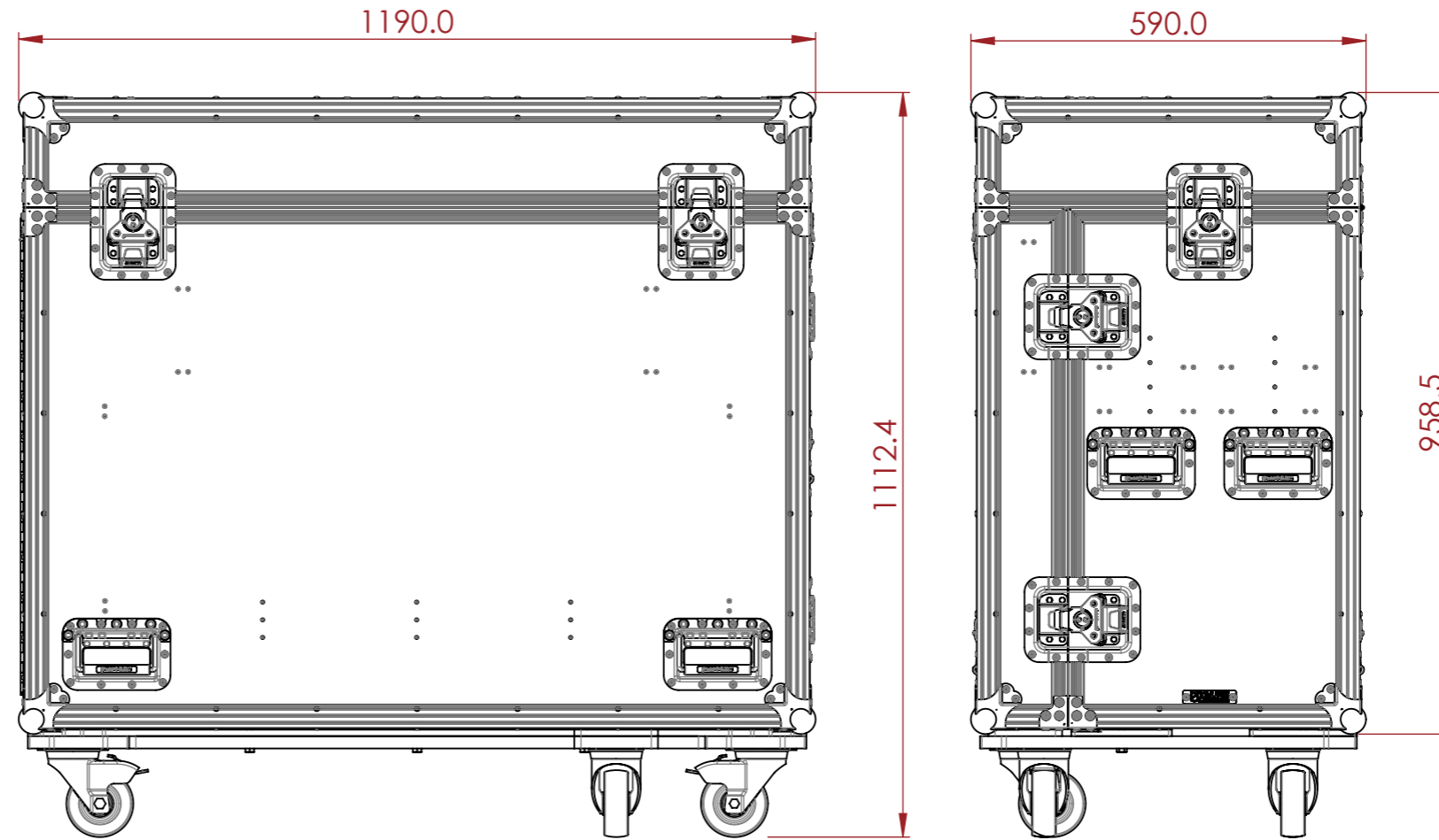

NOTES:

UNLESS SPECIFIED IN THE DRAWING, ALL PRODUCTS DISPLAYED IN THIS DRAWING OTHER THAN THE CASE ITSELF IS NOT PART OF OUR PRODUCT OFFERING.

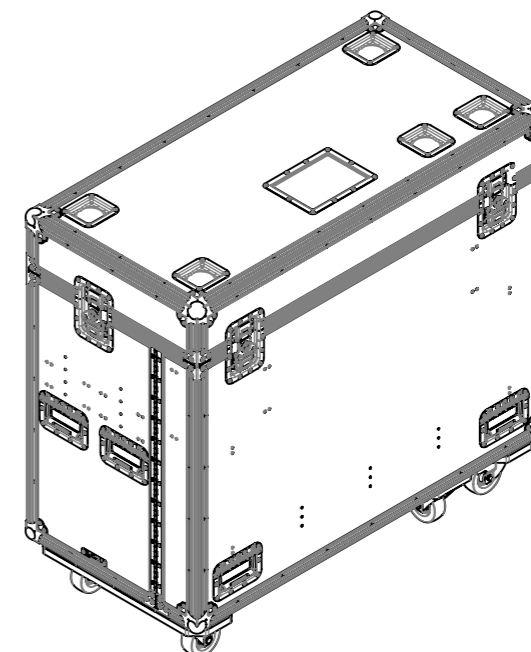
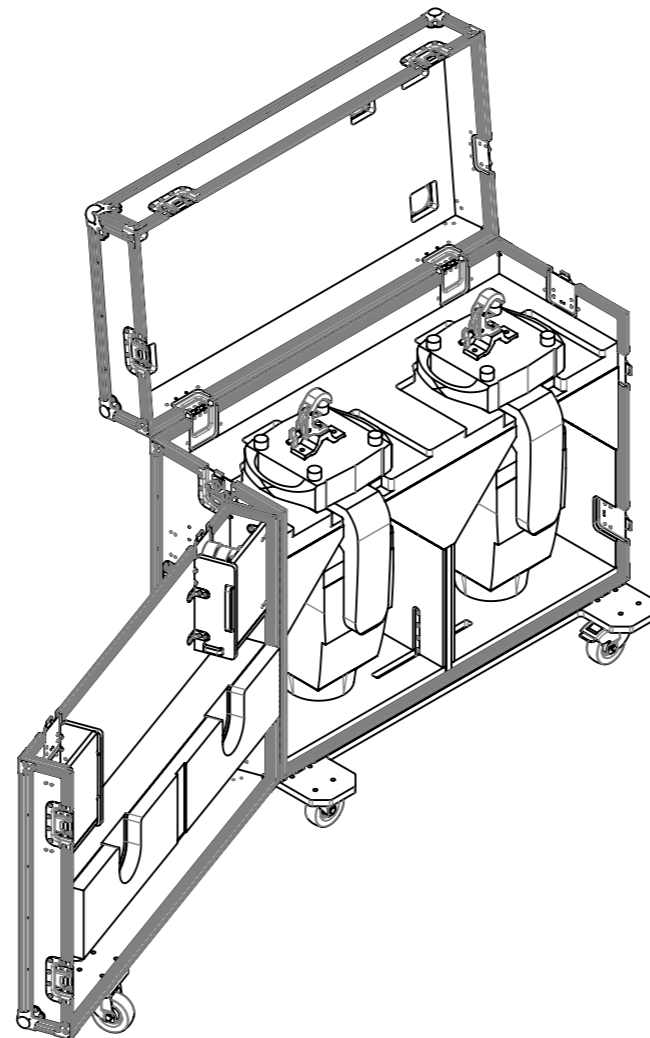
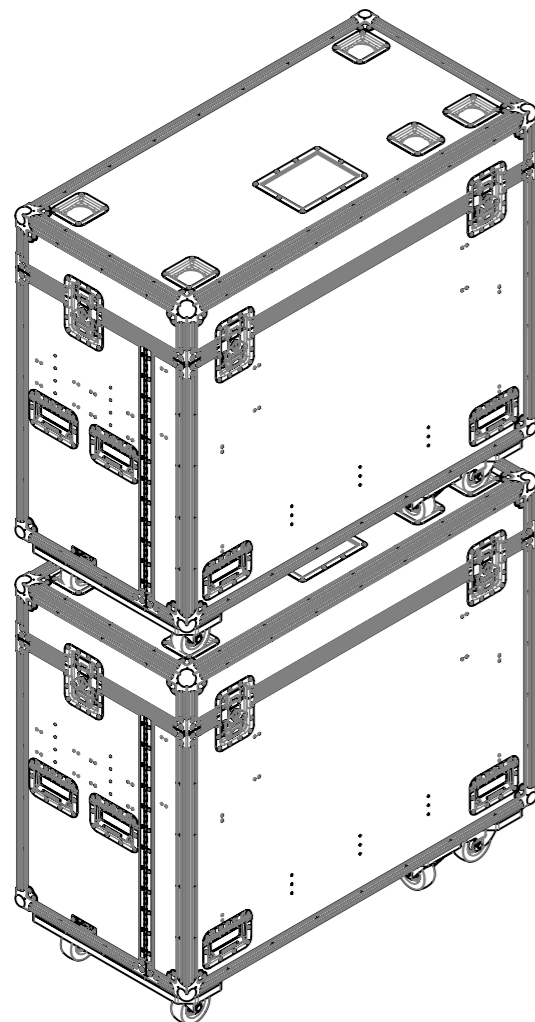

ESTIMATED WEIGHT (CASE ONLY):

100.8 KG

ITEM CODE:

LXMHFL-SPRO-P550H

DRAWN BY:

HA

CHECKED BY:

AS

SCALE:

NTS



MAIL : sales@armorcases.com.au
WEB : www.armorcases.com.au