

YOUR SIGNATURE IS REQUIRED FOR APPROVAL BEFORE ANY RELEASE OF PRODUCTION DRAWINGS

SIGNATURE

DATE

TOLERANCES

CUTOUTS +/- 1/16

OVERALL FOAM THICKNESS & CAVITY DEPTHS +/- 1/8

GLUED TO CASE TOP BASE VELCRO EXTRA

REVISIONS

REV.	DESCRIPTION	DATE	INIT
p.00	PRODUCTION DRAWING	2/1/2018	MK

LID TRAY - ELEVATION

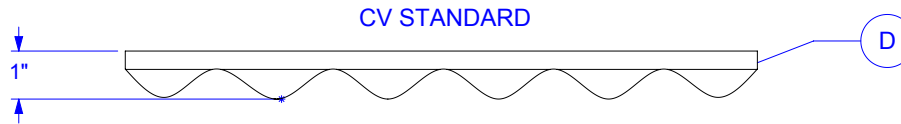

BASE TRAY

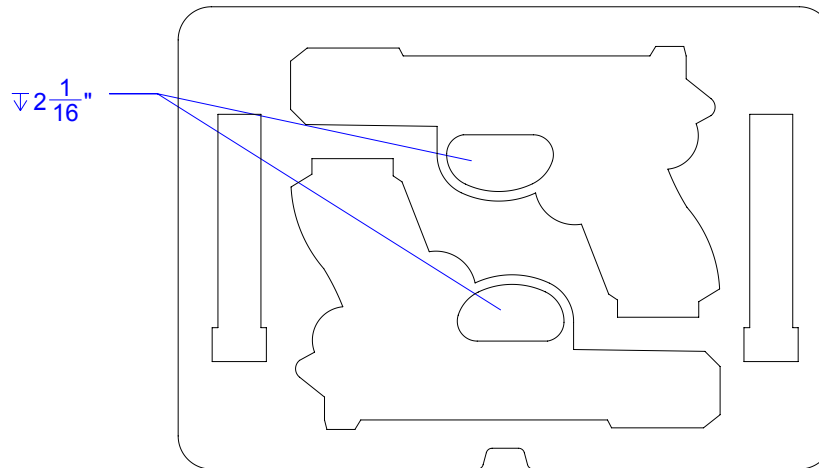

CAVITIES ARE ∇ 1"
 UNLESS OTHERWISE INDICATED

TOUTES LES CAVITÉES ONT ∇ 1"
 SAUF CELLES INDIQUÉES

BASE TRAY - ELEVATION

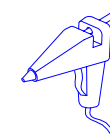
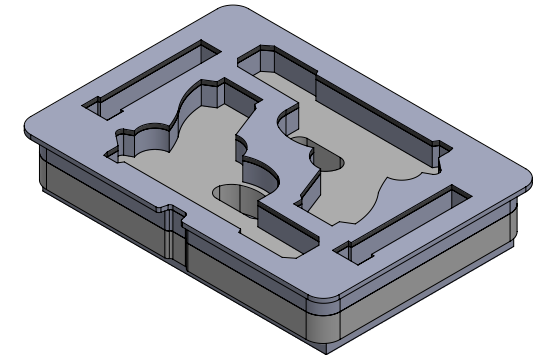
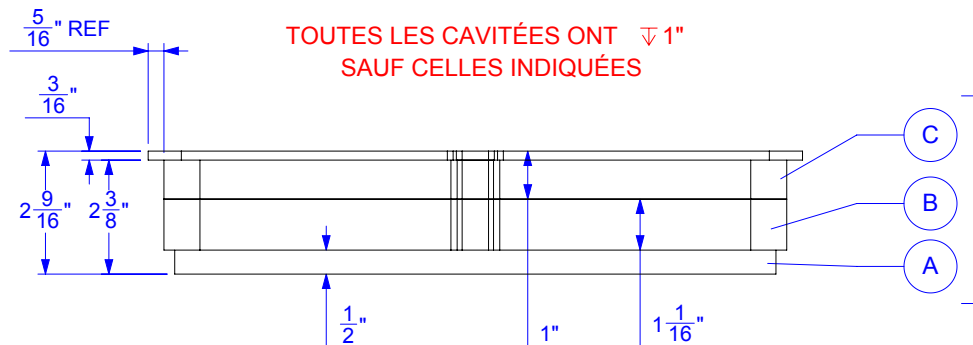

FOAM DENSITY MAY VARY
 DIMENSIONS ARE IN INCHES UNLESS OTHERWISE SPECIFIED

YOUR SIGNATURE IS REQUIRED FOR APPROVAL BEFORE ANY RELEASE OF PRODUCTION DRAWINGS

SIGNATURE

DATE

TOLERANCES

CUTOUTS +/- 1/16

OVERALL FOAM THICKNESS & CAVITY DEPTHS +/- 1/8

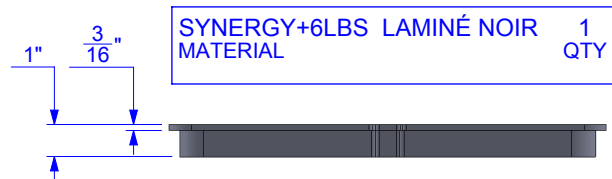
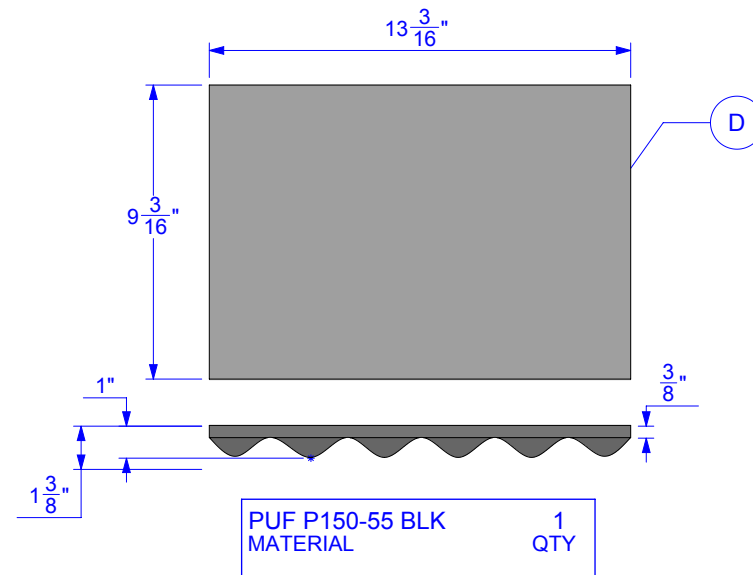
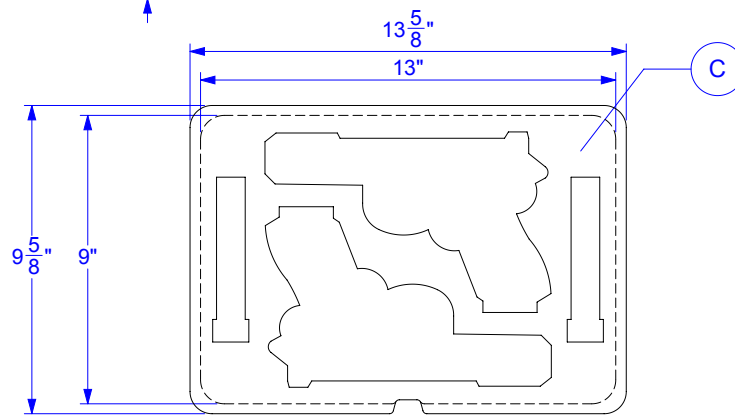
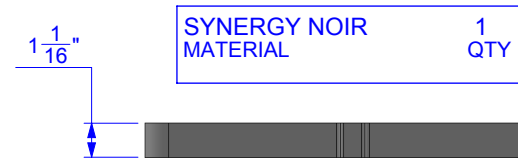
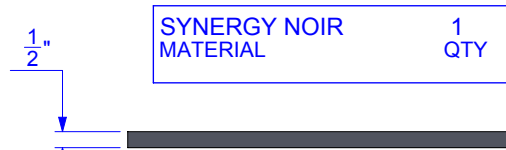
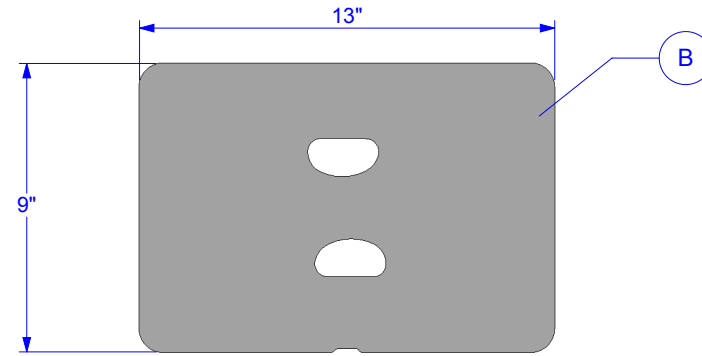
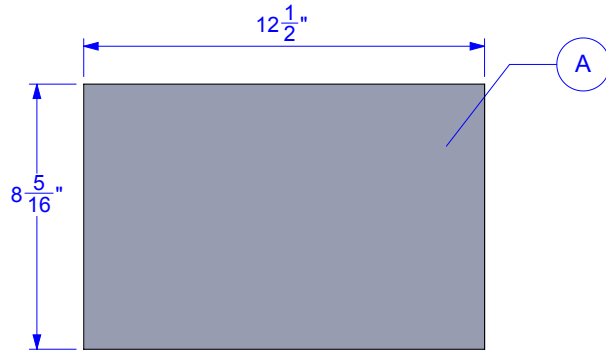

FOAM DENSITY MAY VARY
 DIMENSIONS ARE IN INCHES UNLESS OTHERWISE SPECIFIED



1059, boulevard des Entreprises Ouest
 Terrebonne, QC Canada J6Y 1V2
 Tel 450-628-1006 1.800.783.6883
 Fax 450-628-7801 1.888.783.6883
 www.plasticase.com

2 GLOCKS

PROJECT

910_NANUK

PRODUCT

18002FV.910_PLASTICASE_2_GLOCKS_p.00

DWG ID

STATUS

YOUR SIGNATURE IS REQUIRED FOR APPROVAL BEFORE ANY RELEASE OF PRODUCTION DRAWINGS

TOLERANCES

CUTOUTS +/- 1/16

OVERALL FOAM THICKNESS & CAVITY DEPTHS +/- 1/8

SIGNATURE

DATE

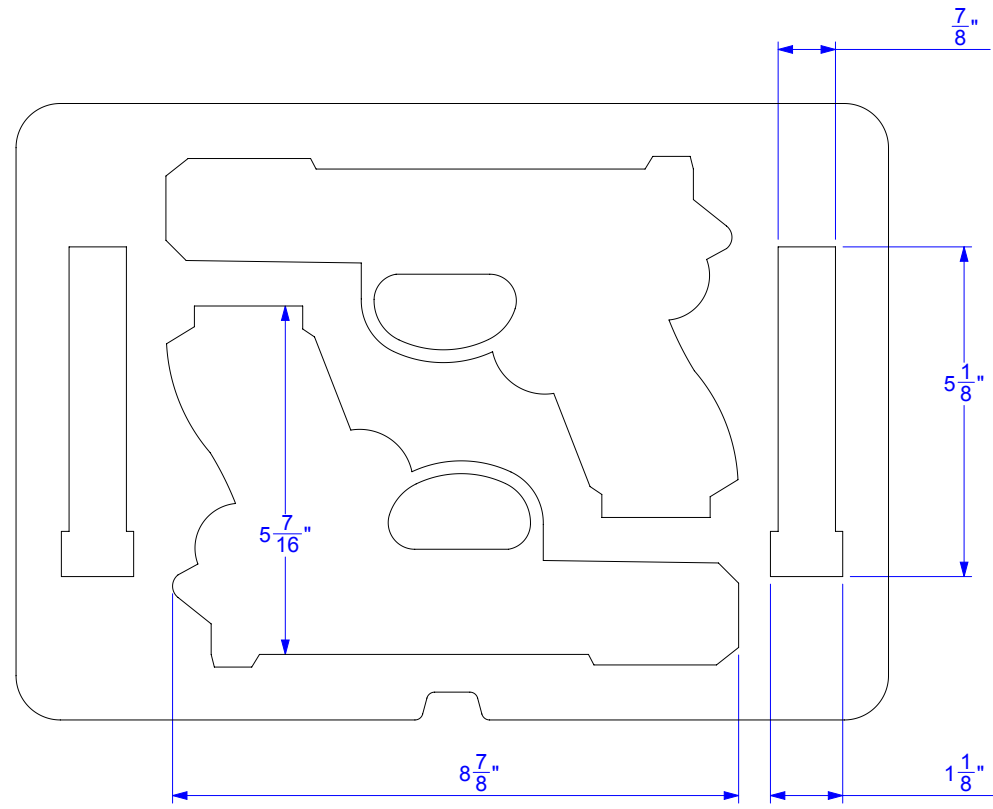

FOAM DENSITY MAY VARY. DIMENSIONS ARE IN INCHES UNLESS OTHERWISE SPECIFIED

PROPRIETARY AND CONFIDENTIAL

THE INFORMATION CONTAINED IN THIS DRAWING IS THE SOLE & EXCLUSIVE PROPERTY OF PLASTICASE INC. ANY REPRODUCTION IN PART OR WHOLE WITHOUT THE WRITTEN PERMISSION OF PLASTICASE INC. IS PROHIBITED.

DO NOT SCALE DRAWING
 SHEET SCALE 1:3

Frank Vitiello
 REPRESENTATIVE

Martin Keighan
 DESIGNER

2018-01-11
 DATE

3/6