

YOUR SIGNATURE IS REQUIRED FOR APPROVAL BEFORE ANY RELEASE OF PRODUCTION DRAWINGS

SIGNATURE

DATE

TOLERANCES

CUTOUTS +/- 1/16

OVERALL FOAM THICKNESS & CAVITY DEPTHS +/- 1/8

GLUED TO CASE TOP BASE VELCRO EXTRA

REVISIONS

REV.	DESCRIPTION	DATE	INIT
p.00	MODIFICATION AND PRODUCTION OF a.00	2023-05-19	DB

LID TRAY - ELEVATION

1-92503

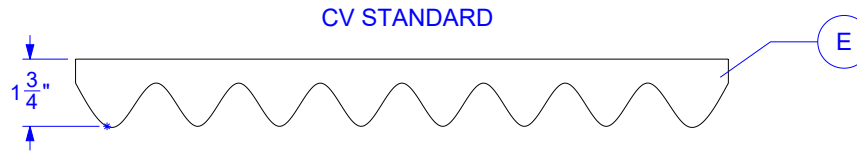

CV STANDARD

BASE TRAY

1-925-C1268-B

CAVITIES ARE 3 3/4" UNLESS OTHERWISE INDICATED

TOUTES LES CAVITÉS ONT 3 3/4" SAUF CELLES INDIQUÉES

PLUG

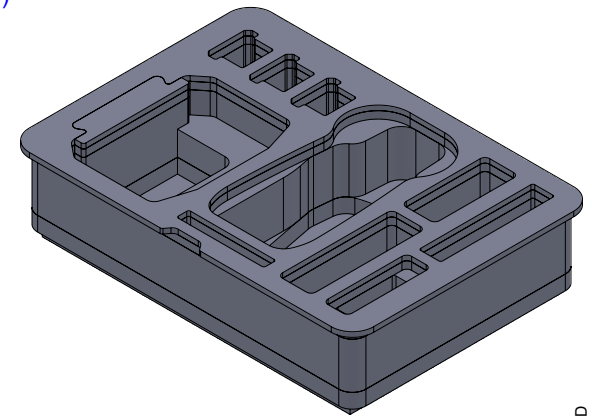
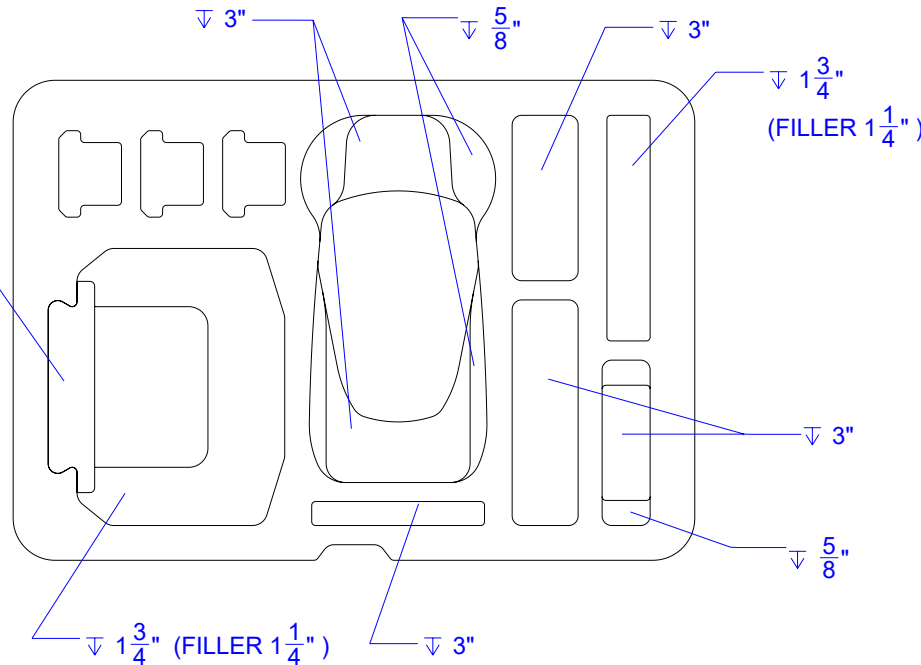

BASE TRAY - ELEVATION

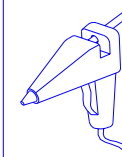
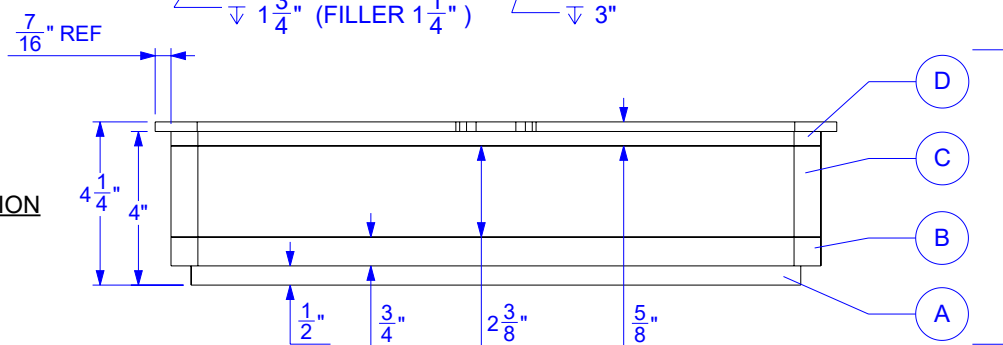

FOAM DENSITY MAY VARY. DIMENSIONS ARE IN INCHES UNLESS OTHERWISE SPECIFIED

YOUR SIGNATURE IS REQUIRED FOR APPROVAL BEFORE ANY RELEASE OF PRODUCTION DRAWINGS

TOLERANCES

CUTOUTS +/- 1/16

OVERALL FOAM THICKNESS & CAVITY DEPTHS +/- 1/8

SIGNATURE

DATE

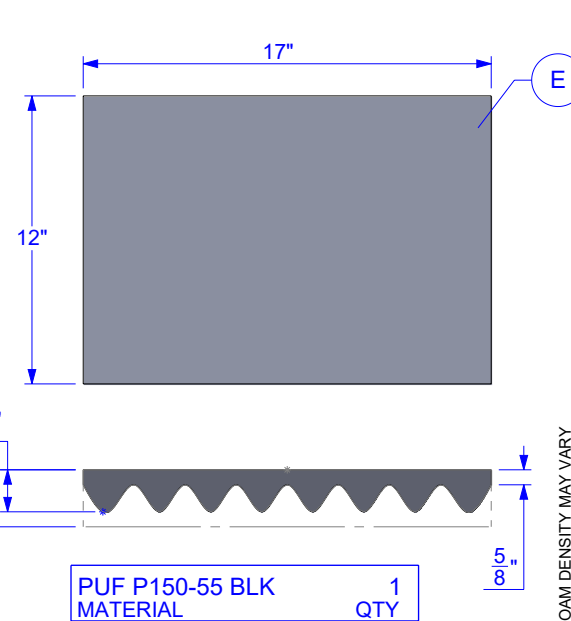
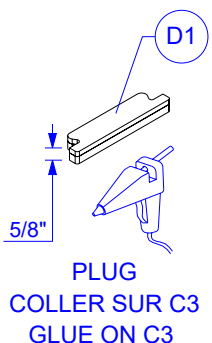
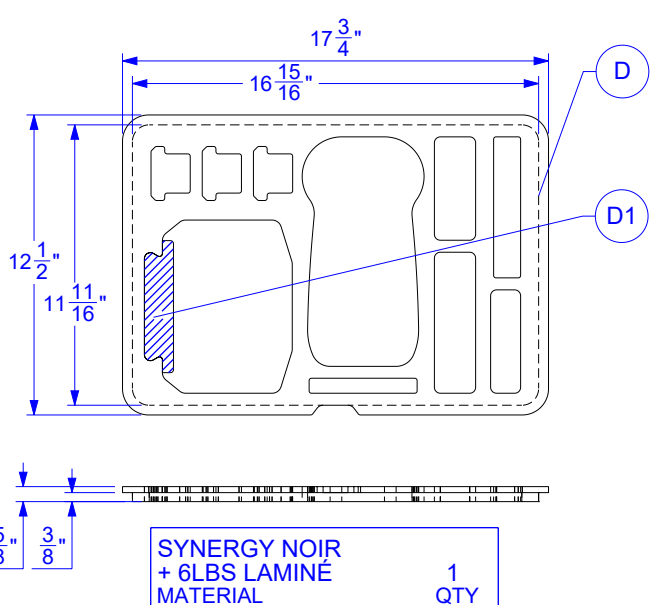
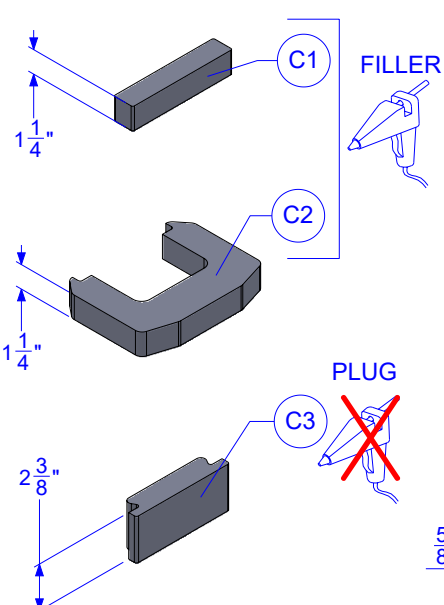
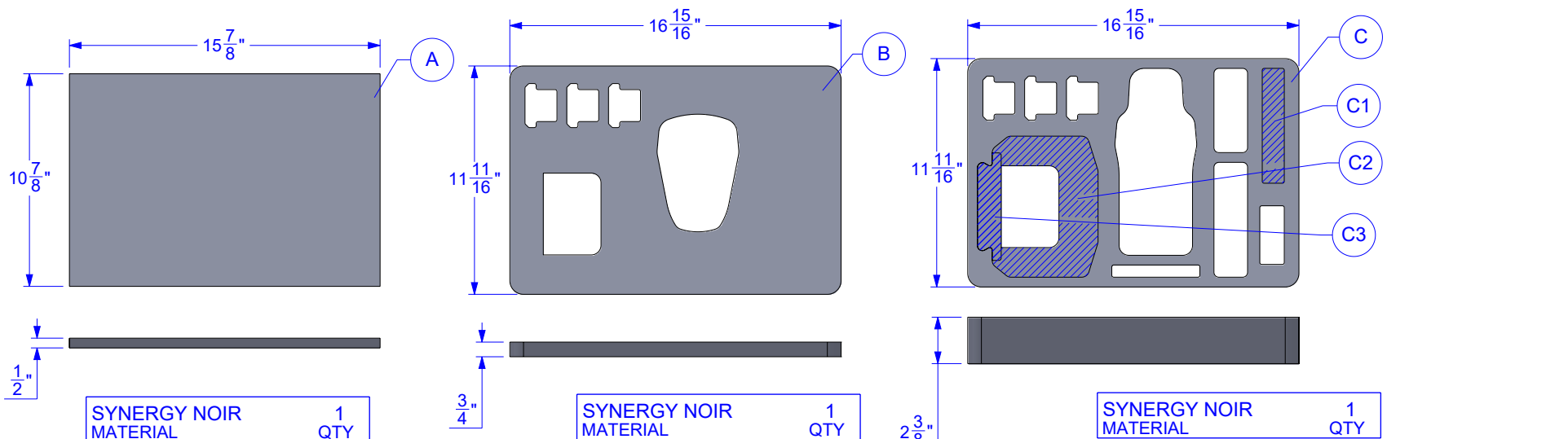

FOAM DENSITY MAY VARY. DIMENSIONS ARE IN INCHES UNLESS OTHERWISE SPECIFIED

