

YOUR SIGNATURE IS REQUIRED FOR APPROVAL BEFORE ANY RELEASE OF PRODUCTION DRAWINGS

SIGNATURE

DATE

TOLERANCES

CUTOUTS +/- 1/16

OVERALL FOAM THICKNESS & CAVITY DEPTHS +/- 1/8

GLUED TO CASE TOP BASE VELCRO EXTRA

REVISIONS

REV.	DESCRIPTION	DATE	INIT
a.01	MODIFIED CUTOUT	21-11-18	WV
a.02	ADDED THUMBS-CUT	21-11-25	WV
a.03	MODIFIED CUTOUT	2021-12-21	DB
p.00	MISE EN PRODUCTION VERSION a.03	2022-04-26	WV

LID TRAY - ELEVATION

631-9103

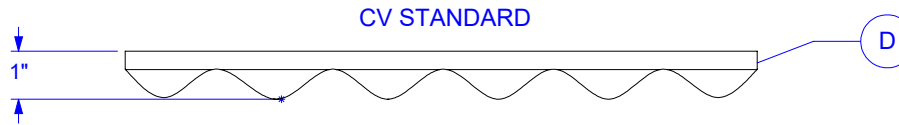

METTRE PLUS DE COLLE
ADD MORE GLUE

BASE TRAY

631-910_21312_B

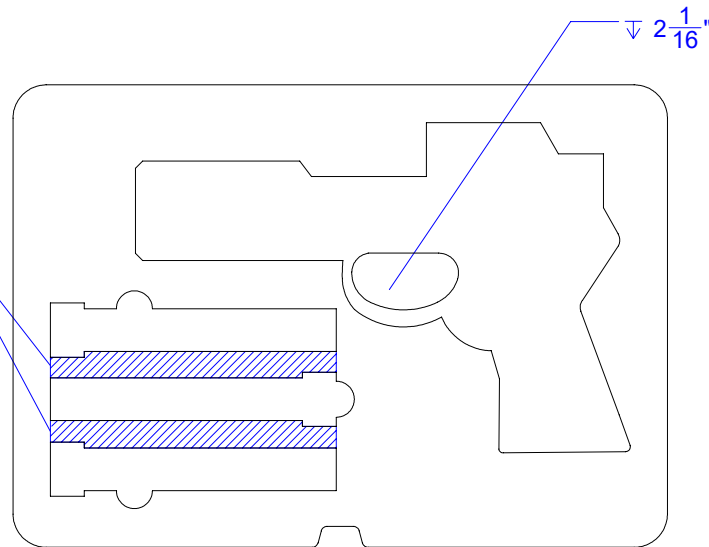

CAVITIES ARE 1" UNLESS OTHERWISE INDICATED

TOUTES LES CAVITÉES ONT 1" SAUF CELLES INDIQUÉES

BASE TRAY - ELEVATION

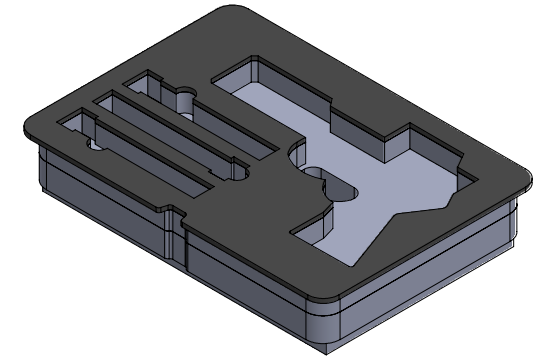
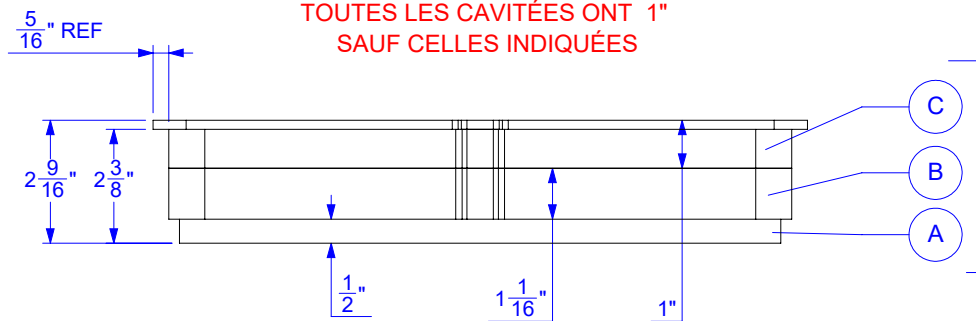

FOAM DENSITY MAY VARY. DIMENSIONS ARE IN INCHES UNLESS OTHERWISE SPECIFIED



1059, boulevard des Entreprises Ouest
 Terrebonne, QC Canada J6Y 1V2
 Tel 450-628-1006 1.800.783.6883
 Fax 450-628-7801 1.888.783.6883
 www.plasticase.com

OPTIC READY HANDGUN

910_NANUK

21312FV.910_PLASTICASE_OPTIC READY
 HANDGUN_p.00

PROJECT

PRODUCT

DWG ID

STATUS

YOUR SIGNATURE IS REQUIRED FOR APPROVAL BEFORE ANY RELEASE OF PRODUCTION DRAWINGS

TOLERANCES

CUTOUTS +/- 1/16

OVERALL FOAM THICKNESS & CAVITY DEPTHS +/- 1/8

SIGNATURE

DATE

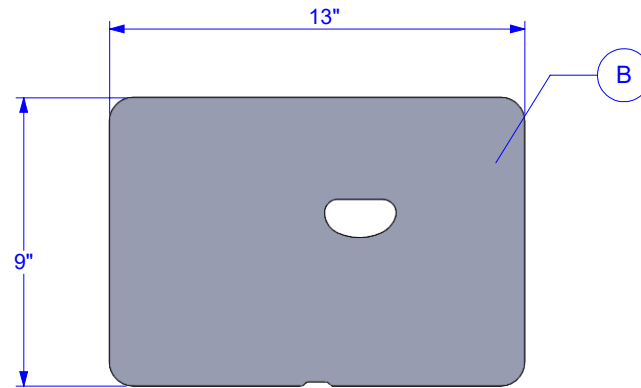
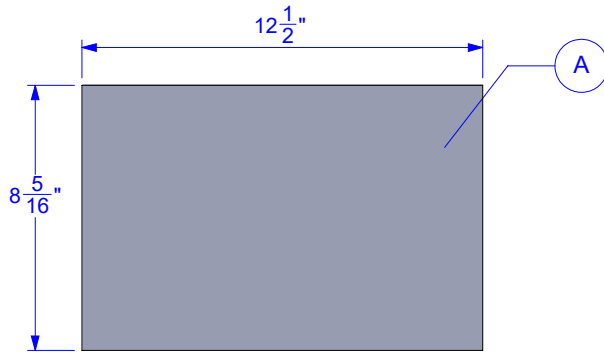

SYNERGY NOIR MATERIAL 1 QTY

SYNERGY NOIR MATERIAL 1 QTY

FOAM DENSITY MAY VARY. DIMENSIONS ARE IN INCHES UNLESS OTHERWISE SPECIFIED

PROPRIETARY AND CONFIDENTIAL

THE INFORMATION CONTAINED IN THIS DRAWING IS THE SOLE & EXCLUSIVE PROPERTY OF PLASTICASE INC. ANY REPRODUCTION IN PART OR WHOLE WITHOUT THE WRITTEN PERMISSION OF PLASTICASE INC. IS PROHIBITED.

DO NOT SCALE DRAWING
 SHEET SCALE 1:6

Frank Vitiello
 REPRESENTATIVE

Woodyne Veillard
 DESIGNER

2022-07-12
 DATE

2/7



1059, boulevard des Entreprises Ouest
 Terrebonne, QC Canada J6Y 1V2
 Tel 450-628-1006 1.800.783.6883
 Fax 450-628-7801 1.888.783.6883
 www.plasticase.com

OPTIC READY HANDGUN

910_NANUK

21312FV.910_PLASTICASE_OPTIC READY
 HANDGUN_p.00

PROJECT

PRODUCT

DWG ID

STATUS

YOUR SIGNATURE IS REQUIRED FOR APPROVAL BEFORE ANY RELEASE OF PRODUCTION DRAWINGS

TOLERANCES

CUTOUTS +/- 1/16

OVERALL FOAM THICKNESS & CAVITY DEPTHS +/- 1/8

SIGNATURE

DATE

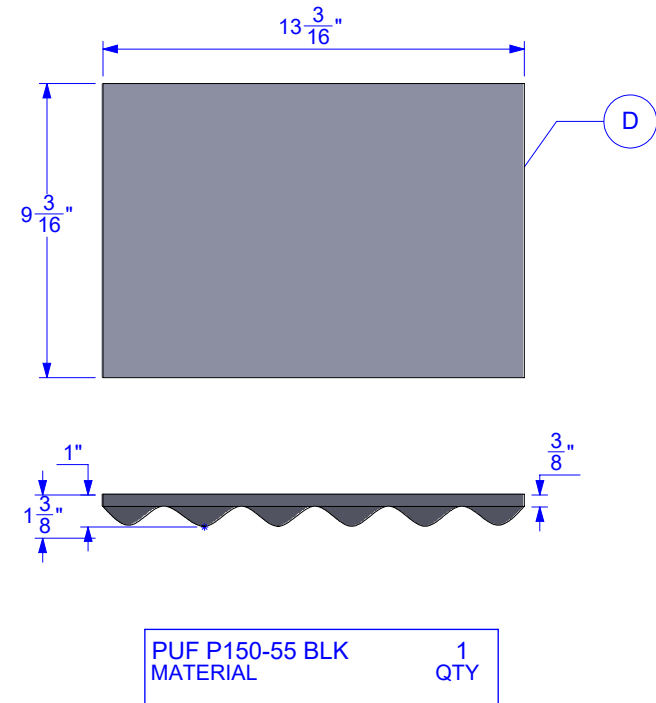
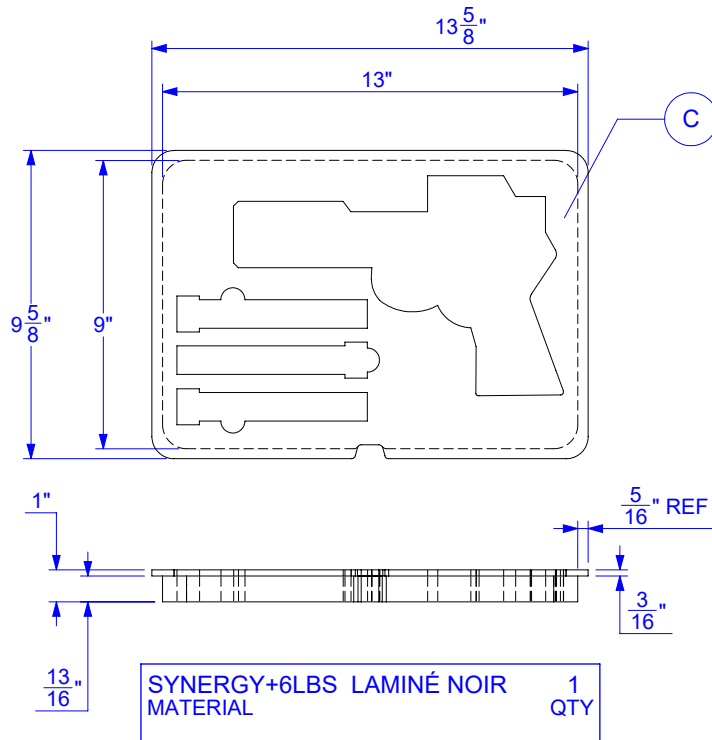

FOAM DENSITY MAY VARY
 DIMENSIONS ARE IN INCHES UNLESS OTHERWISE SPECIFIED

PROPRIETARY AND CONFIDENTIAL

THE INFORMATION CONTAINED IN THIS DRAWING IS THE SOLE & EXCLUSIVE PROPERTY OF PLASTICASE INC.
 ANY REPRODUCTION IN PART OR WHOLE WITHOUT THE WRITTEN PERMISSION OF PLASTICASE INC. IS PROHIBITED.

DO NOT SCALE DRAWING
 SHEET SCALE 1:6

Frank Vitiello
 REPRESENTATIVE

Woodyne Veillard
 DESIGNER

2022-07-12
 DATE

3/7



1059, boulevard des Entreprises Ouest
 Terrebonne, QC Canada J6Y 1V2
 Tel 450-628-1006 1.800.783.6883
 Fax 450-628-7801 1.888.783.6883
 www.plasticase.com

OPTIC READY HANDGUN

PROJECT

910_NANUK

PRODUCT

21312FV.910_PLASTICASE_OPTIC READY
 HANDGUN_p.00

DWG ID

STATUS

YOUR SIGNATURE IS REQUIRED FOR APPROVAL BEFORE ANY RELEASE OF PRODUCTION DRAWINGS

TOLERANCES

CUTOUTS +/- 1/16

OVERALL FOAM THICKNESS & CAVITY DEPTHS +/- 1/8

SIGNATURE

DATE

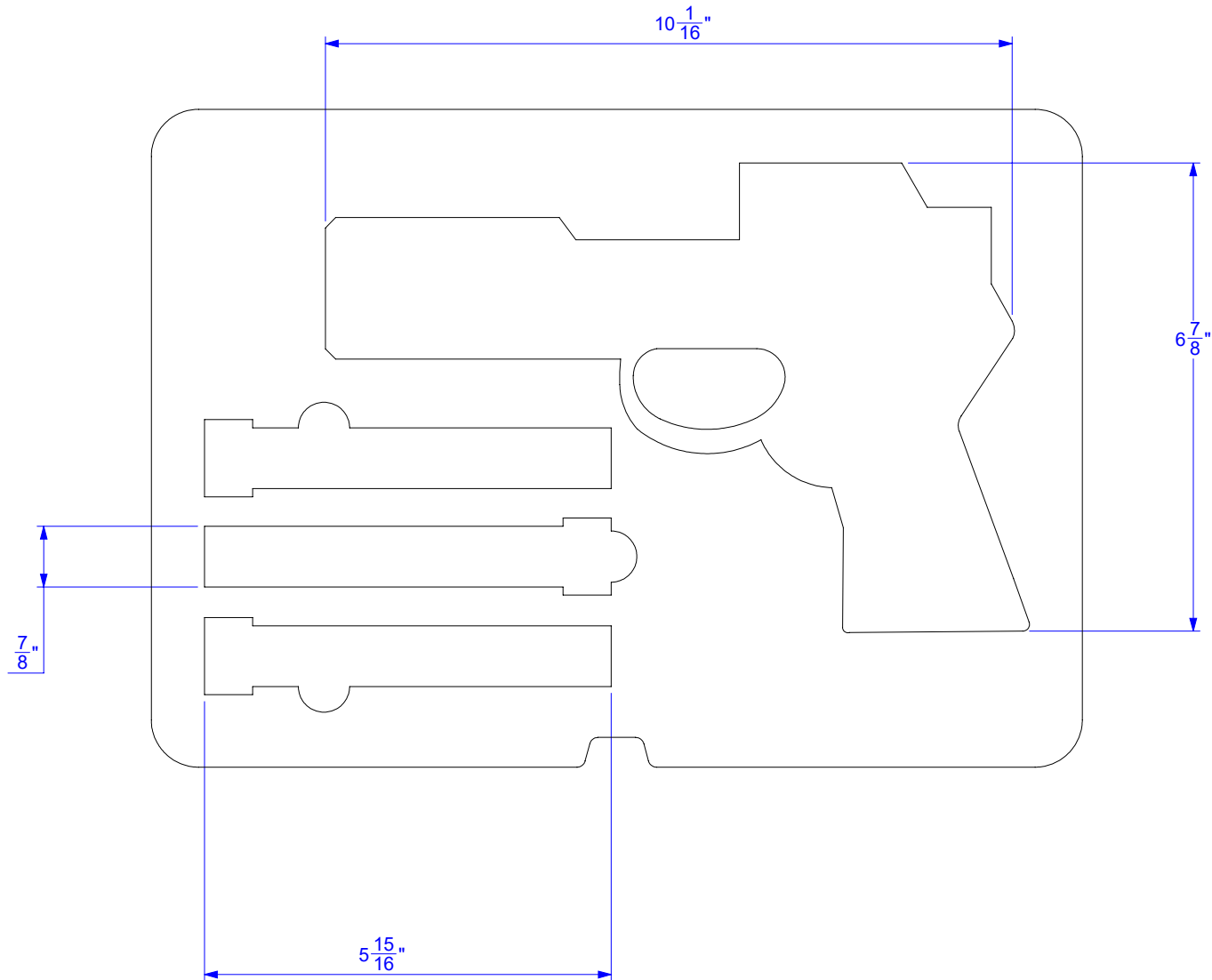

FOAM DENSITY MAY VARY.
 DIMENSIONS ARE IN INCHES UNLESS OTHERWISE SPECIFIED

PROPRIETARY AND CONFIDENTIAL

THE INFORMATION CONTAINED IN THIS DRAWING IS THE SOLE & EXCLUSIVE PROPERTY OF PLASTICASE INC.
 ANY REPRODUCTION IN PART OR WHOLE WITHOUT THE WRITTEN PERMISSION OF PLASTICASE INC. IS PROHIBITED.

DO NOT SCALE DRAWING
 SHEET SCALE 1:3

Frank Vitiello
 REPRESENTATIVE

Woodyne Veillard
 DESIGNER

2022-07-12
 DATE

4/7