

YOUR SIGNATURE IS REQUIRED FOR APPROVAL BEFORE ANY RELEASE OF PRODUCTION DRAWINGS

SIGNATURE

DATE

TOLERANCES

CUTOUTS +/- 1/16

OVERALL FOAM THICKNESS & CAVITY DEPTHS +/- 1/8

GLUED TO CASE TOP BASE VELCRO EXTRA

REVISIONS			
REV.	DESCRIPTION	DATE	INIT
p.00	INITIAL RELEASE	8/11/2016	MK
p.01	MFG REVISION	9/16/2016	MK
p.03	GENERAL REVISION	10/14/2016	MK
p.03.1	NOTE GLUE TO TOP REMOVED	11/7/2017	MK
p.03.2	DRAWING CORRECTION	2/8/2019	MK

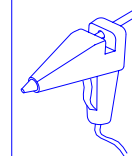
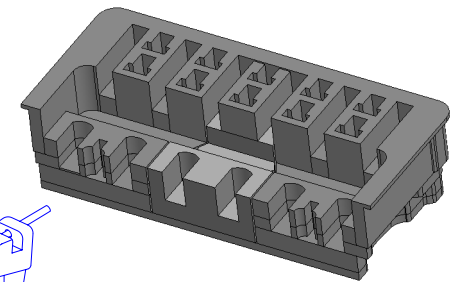
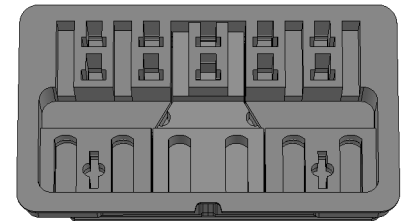
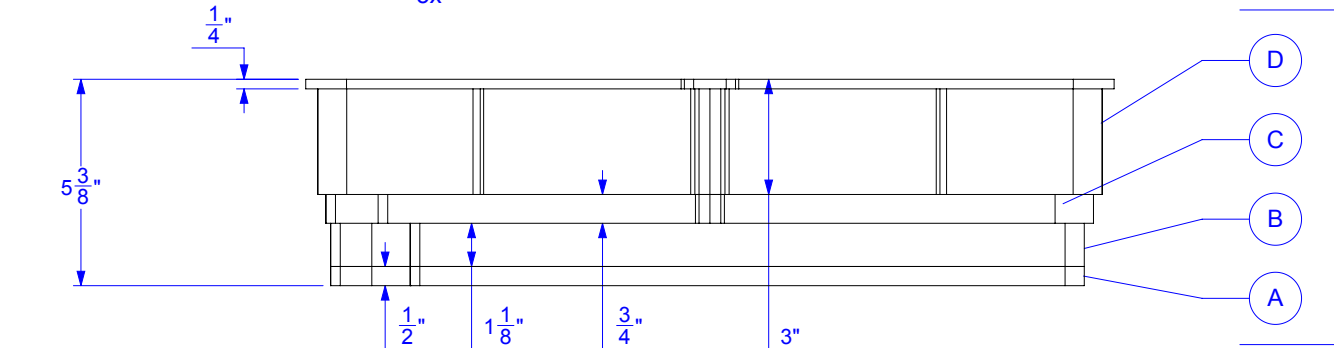
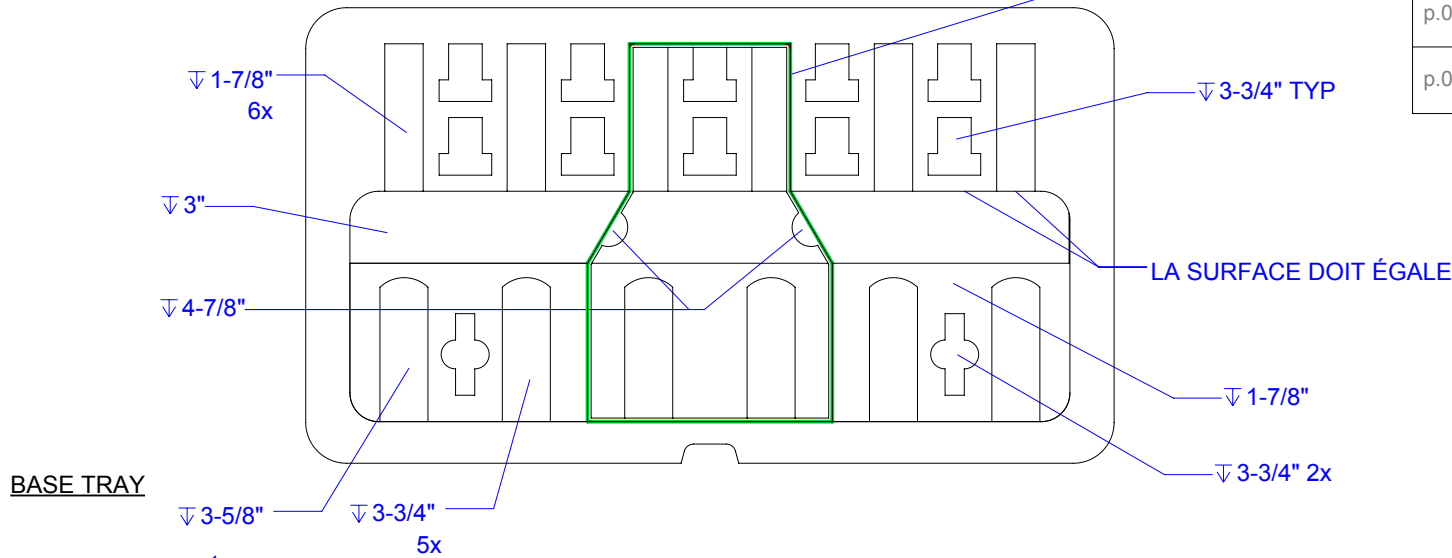
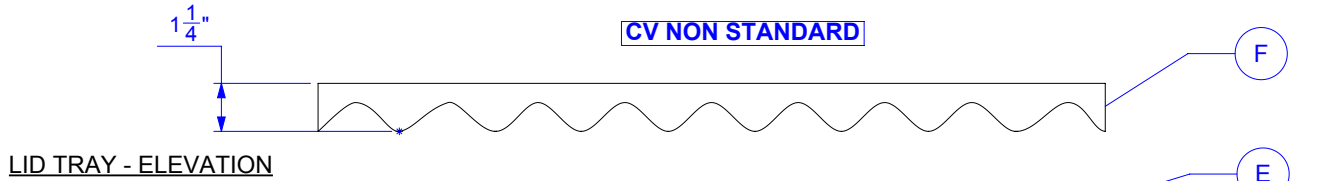

ASSEMBLER DU HAUT
VERS LE BAS

FOAM DENSITY MAY VARY
DIMENSIONS ARE IN INCHES UNLESS OTHERWISE SPECIFIED

YOUR SIGNATURE IS REQUIRED FOR APPROVAL BEFORE ANY RELEASE OF PRODUCTION DRAWINGS

TOLERANCES

CUTOUTS +/- 1/16

OVERALL FOAM THICKNESS & CAVITY DEPTHS +/- 1/8

SIGNATURE

DATE

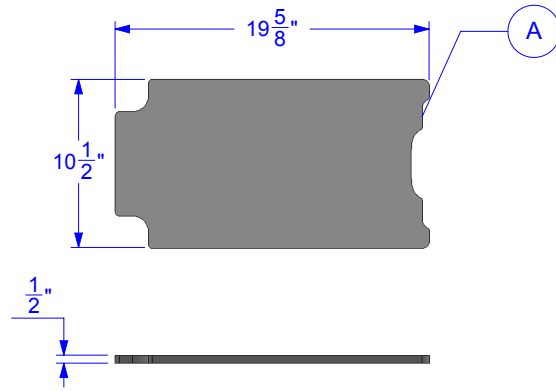

SYNERGY 2.0LBS NOIR		
-	60"	1
LINEAR IN	DETAIL	QTY

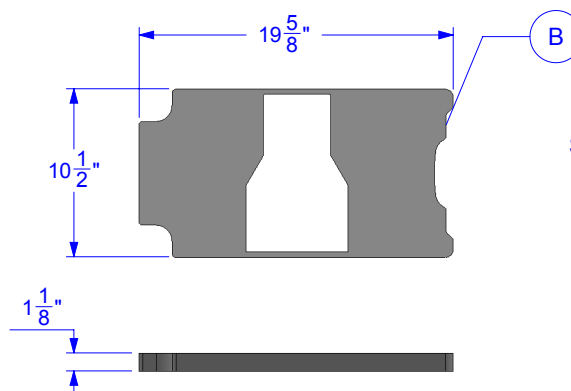

SYNERGY 2.0LBS NOIR		
-	87"	1
LINEAR IN	DETAIL	QTY

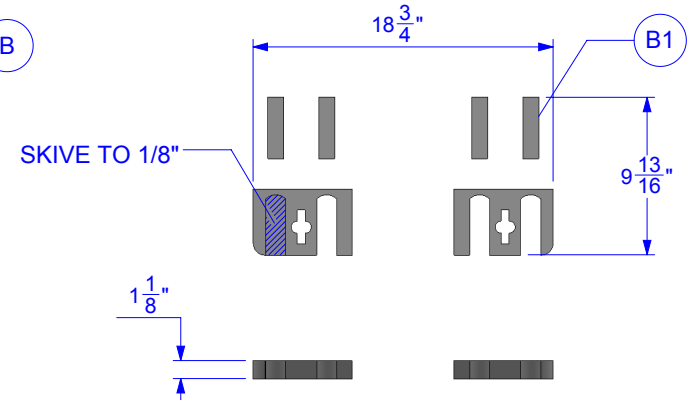

SYNERGY 2.0LBS NOIR		
-	87"	1
LINEAR IN	DETAIL	QTY

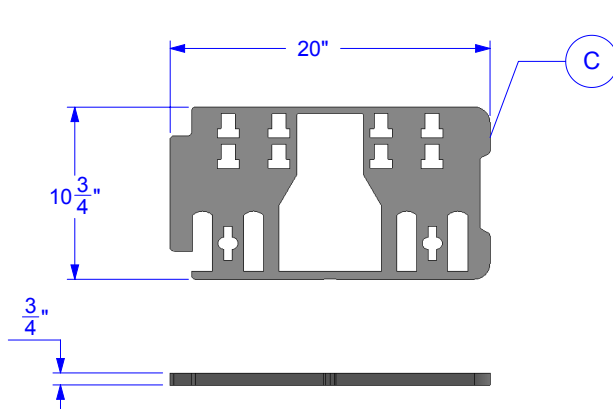

SYNERGY 2.0LBS NOIR		
-	135"	1
LINEAR IN	DETAIL	QTY

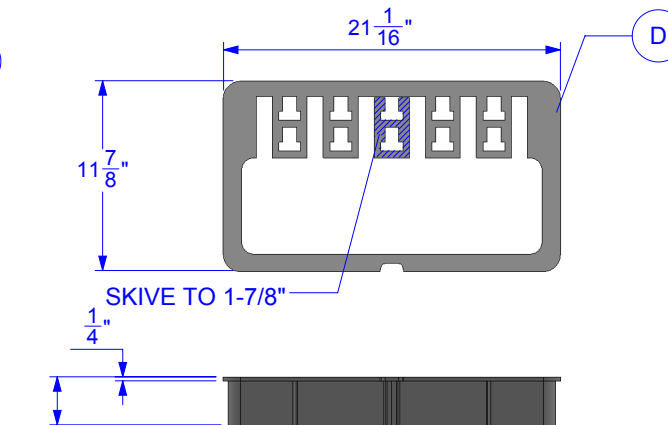

SYNERGY 2.0LBS+6LBS LAMINÉ NOIR		
-	198"	1
LINEAR IN	DETAIL	QTY

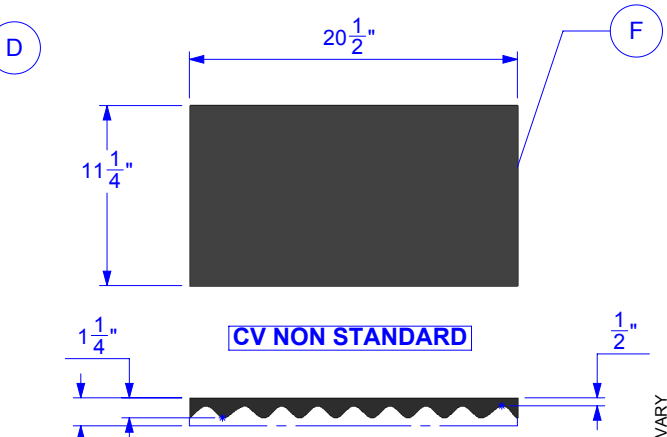

PUF P150-55 BLK 1 3/4" THICK 1/2" BASE		
-	64"	1
LINEAR IN	DETAIL	QTY

FOAM DENSITY MAY VARY
DIMENSIONS ARE IN INCHES UNLESS OTHERWISE SPECIFIED

YOUR SIGNATURE IS REQUIRED FOR APPROVAL BEFORE ANY RELEASE OF PRODUCTION DRAWINGS

SIGNATURE

DATE

TOLERANCES

CUTOUTS +/- 1/16

OVERALL FOAM THICKNESS & CAVITY DEPTHS +/- 1/8

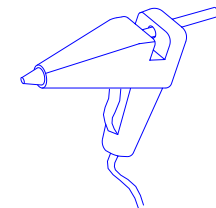
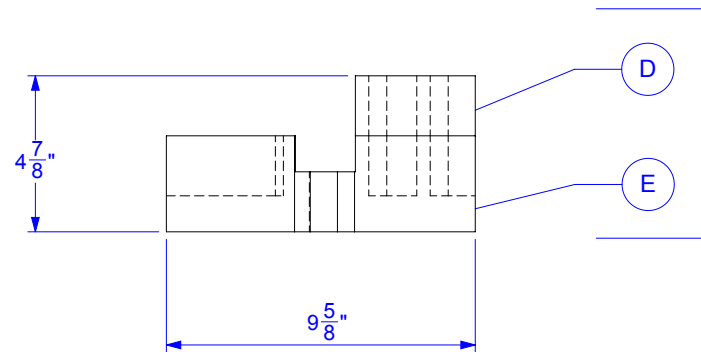
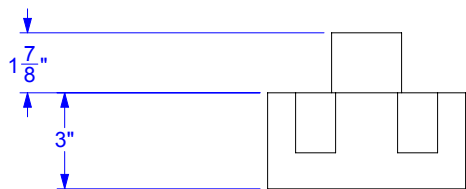
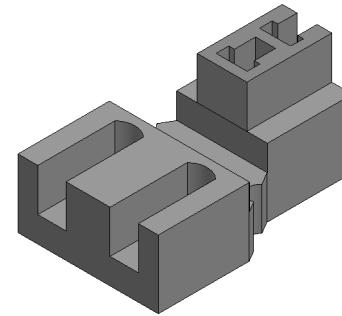
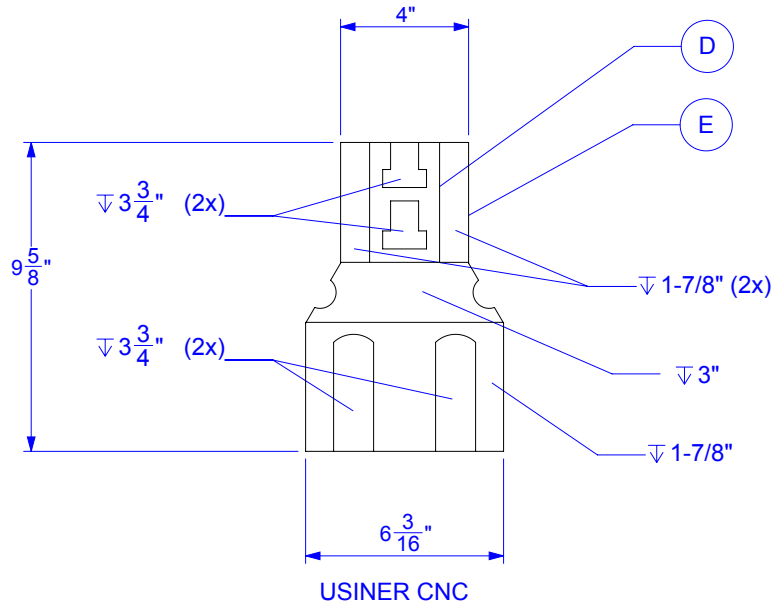

SYNERGY 2.0LBS NOIR		
-	87"	1
LINEAR IN	DETAIL	QTY

FOAM DENSITY MAY VARY. DIMENSIONS ARE IN INCHES UNLESS OTHERWISE SPECIFIED

YOUR SIGNATURE IS REQUIRED FOR APPROVAL BEFORE ANY RELEASE OF PRODUCTION DRAWINGS

TOLERANCES

CUTOUTS +/- 1/16

OVERALL FOAM THICKNESS & CAVITY DEPTHS +/- 1/8

SIGNATURE

DATE

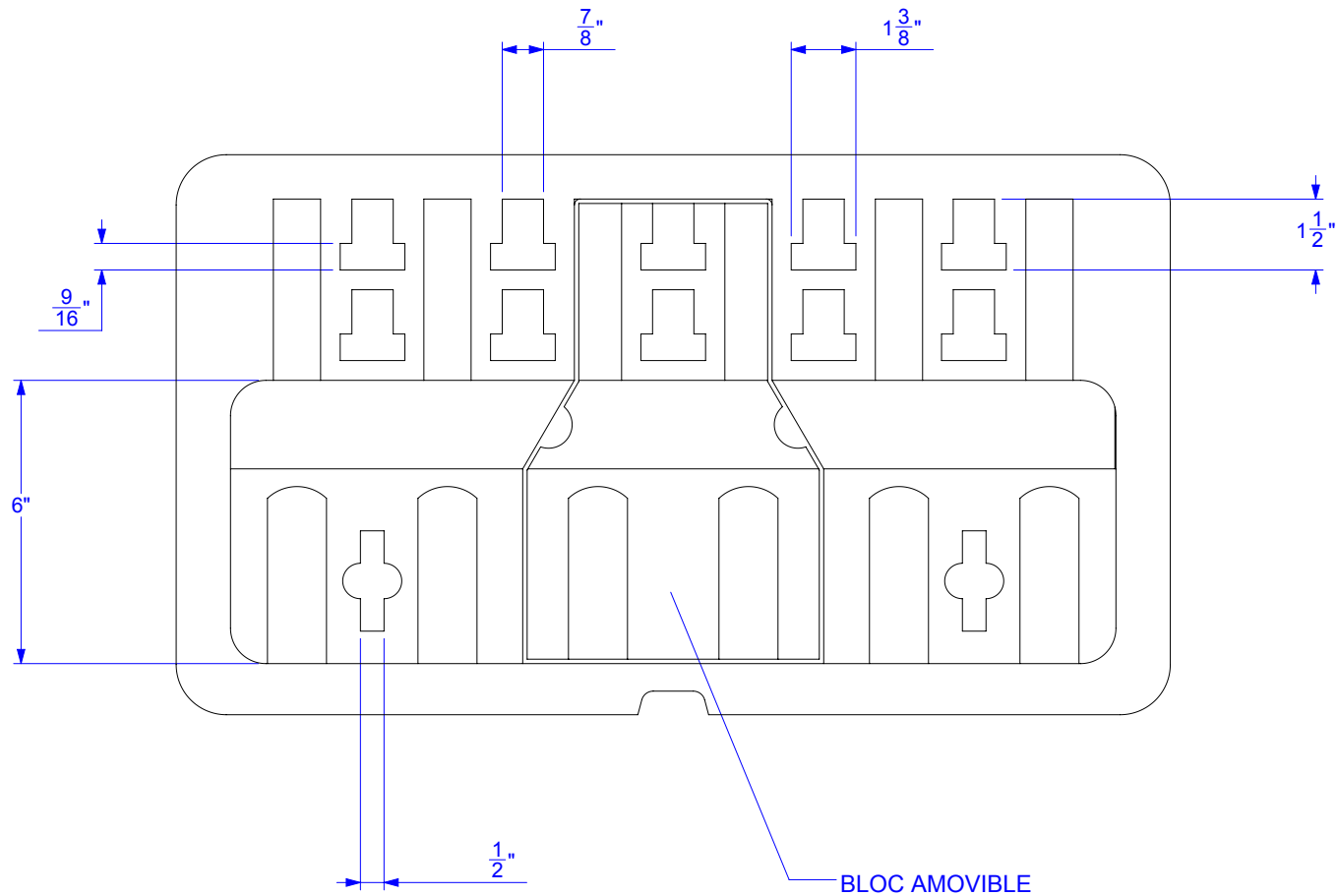

FOAM DENSITY MAY VARY
 DIMENSIONS ARE IN INCHES UNLESS OTHERWISE SPECIFIED