

NOTES:
UNLESS SPECIFIED IN THE DRAWING,
ALL PRODUCTS DISPLAYED IN THIS
DRAWING OTHER THAN THE CASE
ITSELF IS NOT PART OF OUR PRODUCT
OFFERING.

PRODUCT FEATURES

CONSTRUCTION

- 12MM BIRCH VENEER PLYWOOD WITH HPL EXTERIOR FACE AND PVC INTERIOR FACE
- PENN ELCOM HARDWARE.
- 2X ERGONOMICALLY PLACED HANDLES FOR LIFTING AND TRANSPORTING
- MEDIUM LATCHES
- EVA38B FOAM PROTECTION
- 1X D2115 LABEL DISH

FEATURES

- DEDICATED SPACE FOR ALLEN AND HEATH-SQ5
- GENERAL STORAGE SPACE FOR ACCESSORIES
- EASY TO USE LIFT-OFF-LID DESIGN
- COMPACT DESIGN

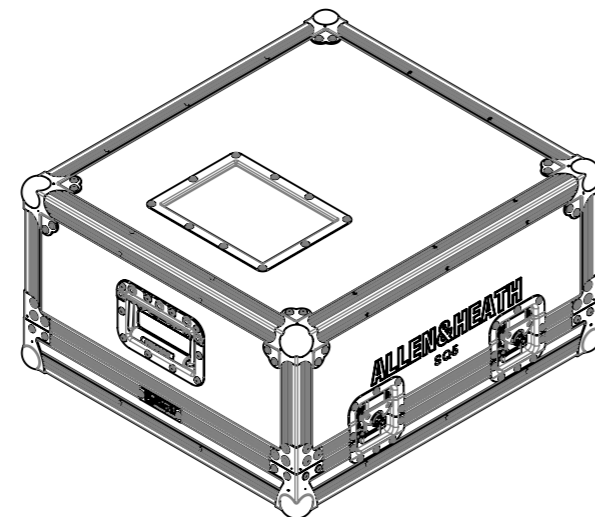

ALLEN AND HEATH SQ-5

STORAGE

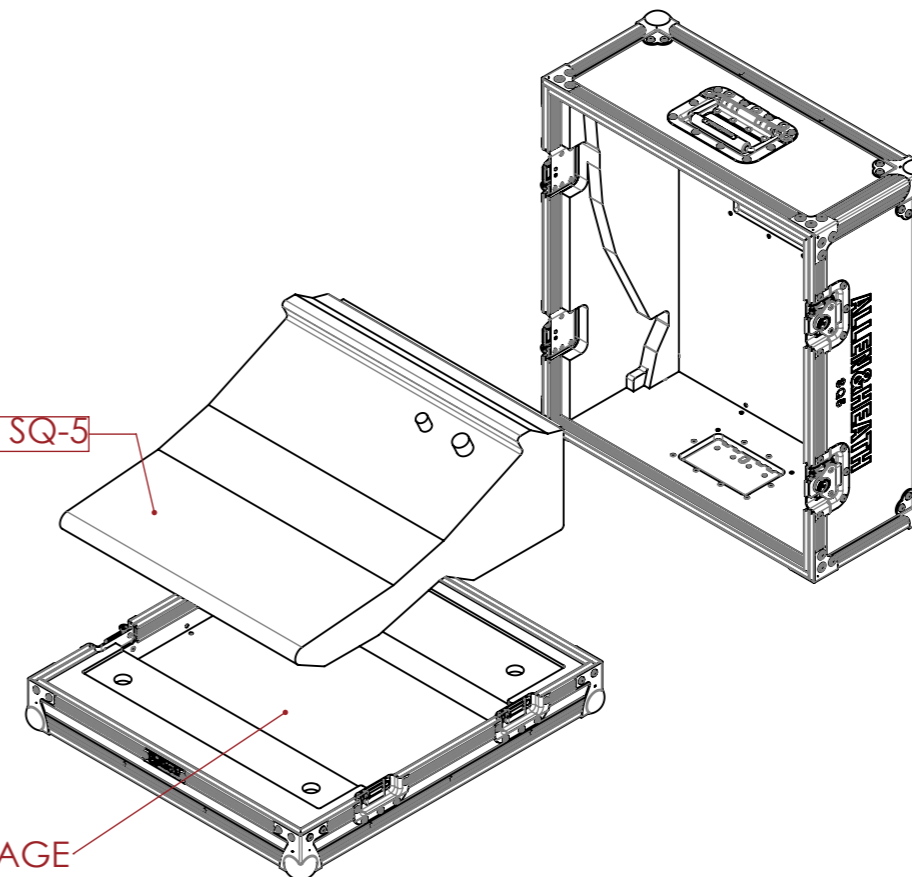

ESTIMATED WEIGHT (CASE ONLY):

14.19 KG

ITEM CODE:

MIXR-AH-SQ5

DRAWN BY:

HA

CHECKED BY:

AS

SCALE:

NTS



MAIL : sales@armorcases.com.au
WEB : www.armorcases.com.au