

PRODUCT FEATURES

CONSTRUCTION

- 9MM BIRCH VENEER PLYWOOD WITH HPL EXTERIOR FACE AND PVC INTERIOR FACE
- PENN ELCOM HARDWARE

INSTALLED EQUIPMENT (INCLUDED)

- VESA MOUNT ARM FOR SUPPORTING A 24 INCH MONITOR (MONITOR NOT INCLUDED)
- FIXED 100X100 VESA MOUNT FOR SUPPORTING A 24 INCH MONITOR (MONITOR NOT INCLUDED)
- LED STRIPS FOR BETTER VIEWING
- 12X RECESSED HANDLES
- 2X BRAKED, 2X NON-BRAKED CASTORS

FEATURES

- STORAGE SPACE FOR 1X GRAND MA3 ONPC COMMAND WING XT
- LABEL DISH FOR EACH OF RECOGNITION
- DRAWER FOR KEYBOARD & MOUSE SETUP

KEY MEASUREMENTS

- N/A

DESIGN SPECIFICATIONS

- 600mm STRAPS WILL BE PROVIDED TO CLIENT FOR ATTACHING EQUIPMENT IN THE DOGBOX

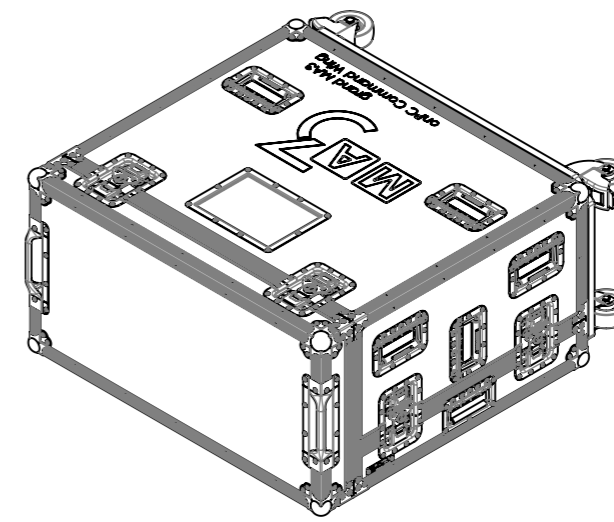
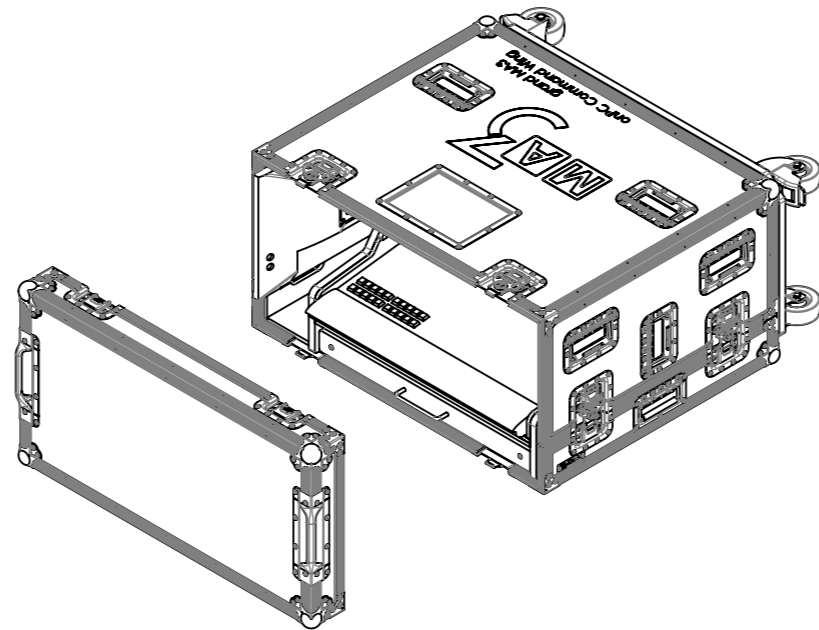
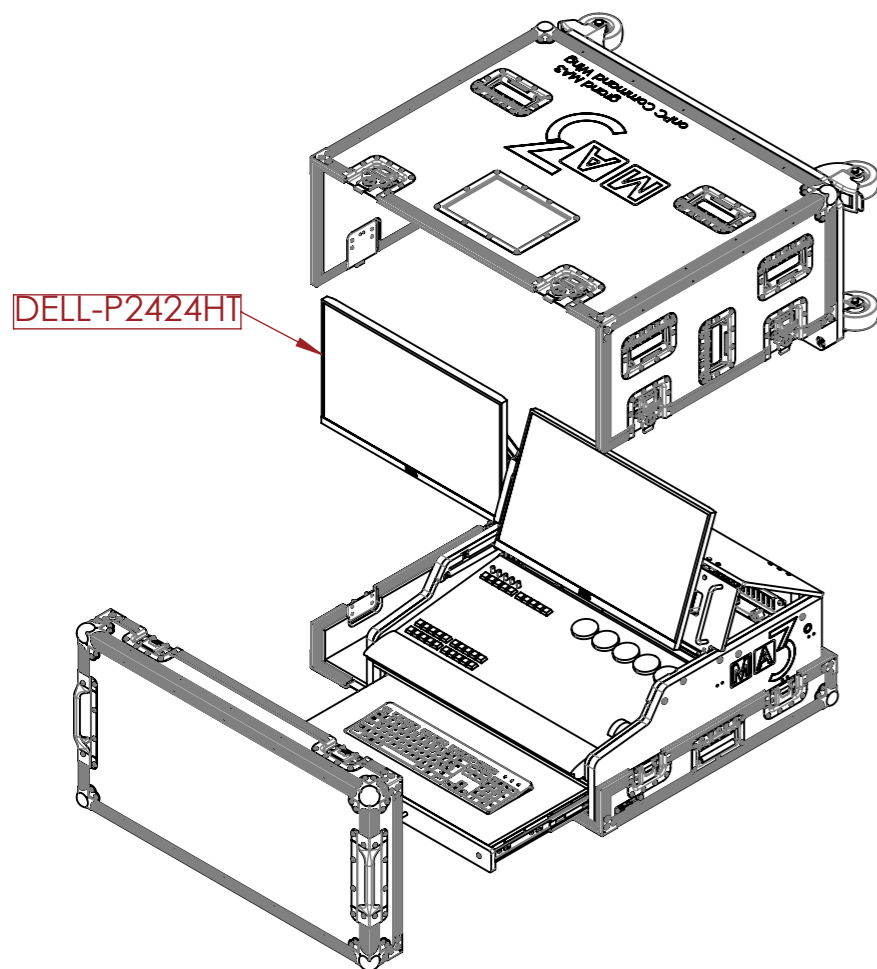
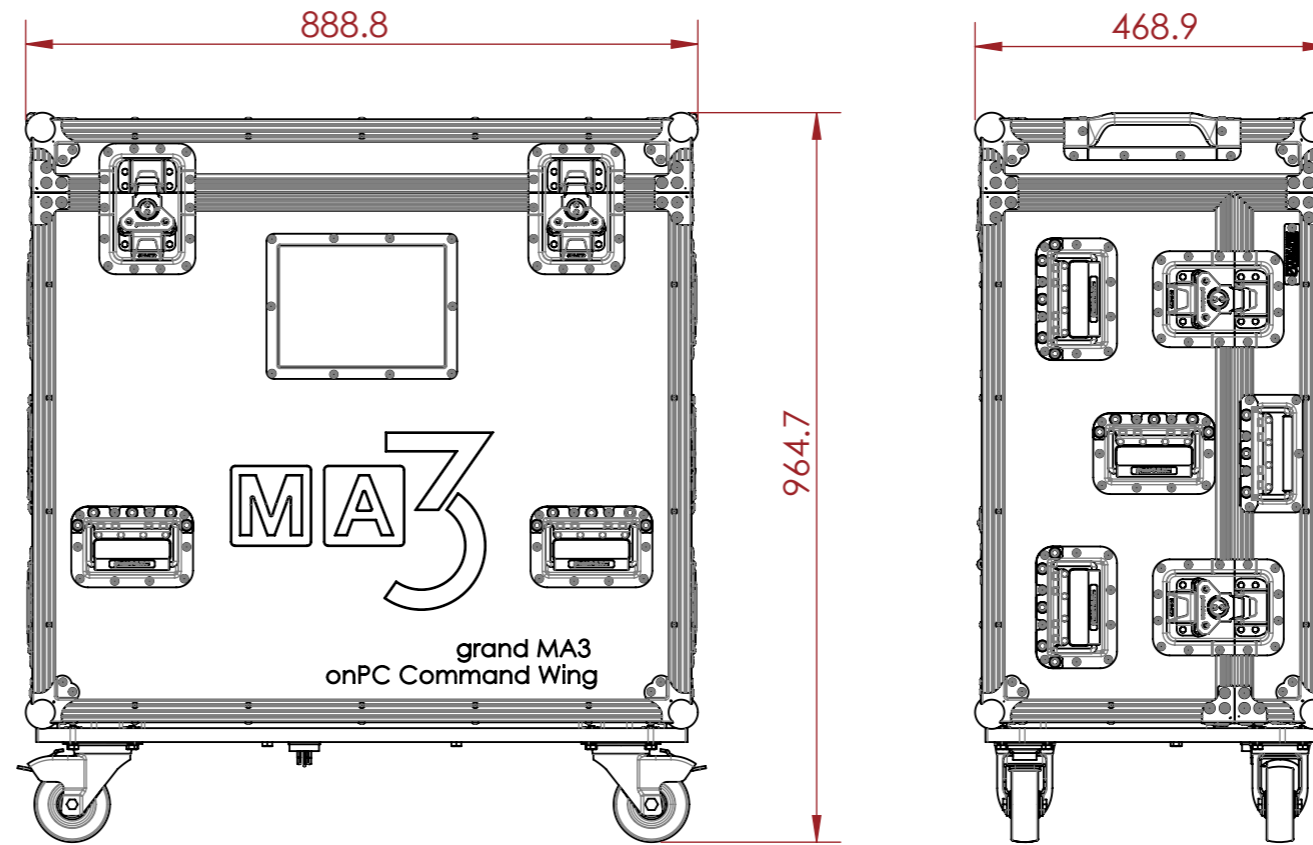

NOTES:
UNLESS SPECIFIED IN THE DRAWING,
ALL PRODUCTS DISPLAYED IN THIS
DRAWING OTHER THAN THE CASE
ITSELF IS NOT PART OF OUR PRODUCT
OFFERING.

ESTIMATED WEIGHT (CASE ONLY):
68.9 KG

ITEM CODE:
LXCTRL-MA3CW-M2

DRAWN BY: HA CHECKED BY: AS

SCALE:
NTS



MAIL : sales@armorcases.com.au
WEB : www.armorcases.com.au