

PRODUCT FEATURES

CONSTRUCTION

- EPA 38 FOAM PROTECTION

INSTALLED EQUIPMENT (INCLUDED)

- N/A

FEATURES

- N/A

KEY MEASUREMENTS

- N/A

DESIGN SPECIFICATIONS

- N/A

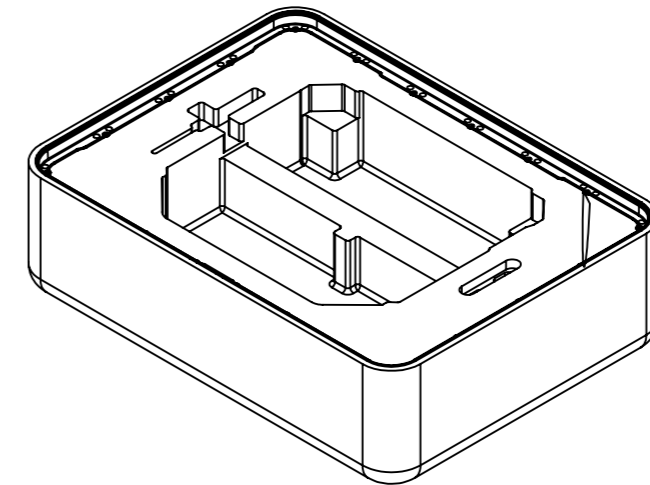
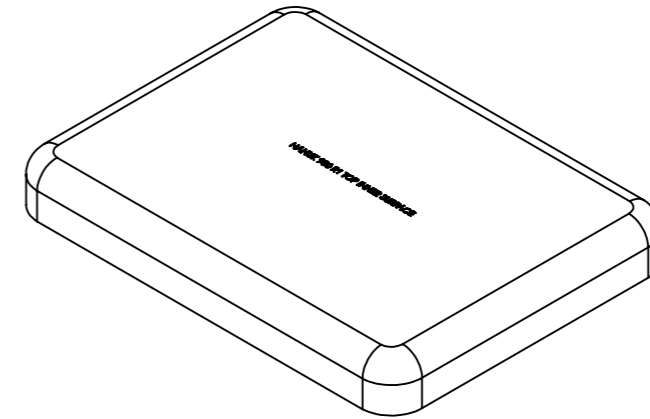
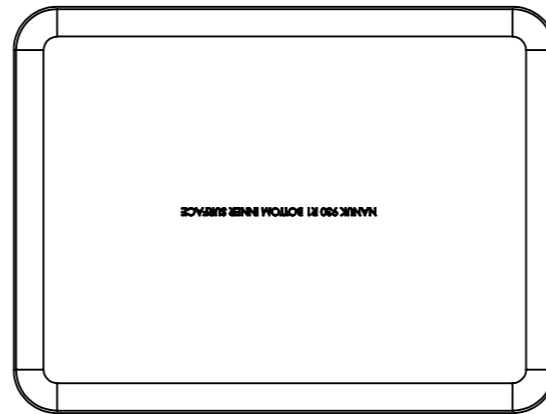
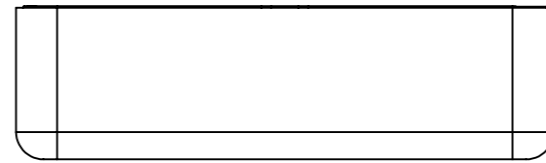
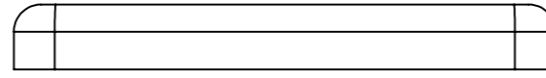

NOTES:

UNLESS SPECIFIED IN THE DRAWING, ALL PRODUCTS DISPLAYED IN THIS DRAWING OTHER THAN THE CASE ITSELF IS NOT PART OF OUR PRODUCT OFFERING.

ESTIMATED WEIGHT (CASE ONLY):

31.29 KG

ITEM CODE:

FI-NNK930-DL7230RE

DRAWN BY:

RP

CHECKED BY:

AS

SCALE:

NTS



MAIL : sales@armorcases.com.au
WEB : www.armorcases.com.au