

PRODUCT FEATURES

CONSTRUCTION

- 12MM BIRCH VENEER PLYWOOD WITH HPL EXTERIOR FACE AND PVC INTERIOR FACE
- PENN ELCOM HARDWARE

INSTALLED EQUIPMENT (INCLUDED)

- SIX MONITOR VESA ATTACHMENTS FOR 27 INCH MONITORS, 100 X 100 VESA MOUNTS
- MONITOR LIFT TO ALLOW SCREENS TO BE ADJUSTED IN HEIGHT

FEATURES

- FRONT LID CAN BE SETUP ON THE RIGHT OR LEFT SIDE OF THE WORKSTATION
- SLAM LID LOCATED ON THE BACK
- DUAL POCKETS LOCATED ON THE LEFT SIDE WITH 100MM WIDTH
- PULL OUT KEYBOARD DRAWER WITH FLIP OUT MOUSE PAD
- GAS STRUTS SUPPORTED TOP LID
- FLIP OUT SECOND MONITOR

KEY MEASUREMENTS

- WORKBENCH HEIGHT AT 920MM
- FOLDABLE TABLE TOP HEIGHT 870MM

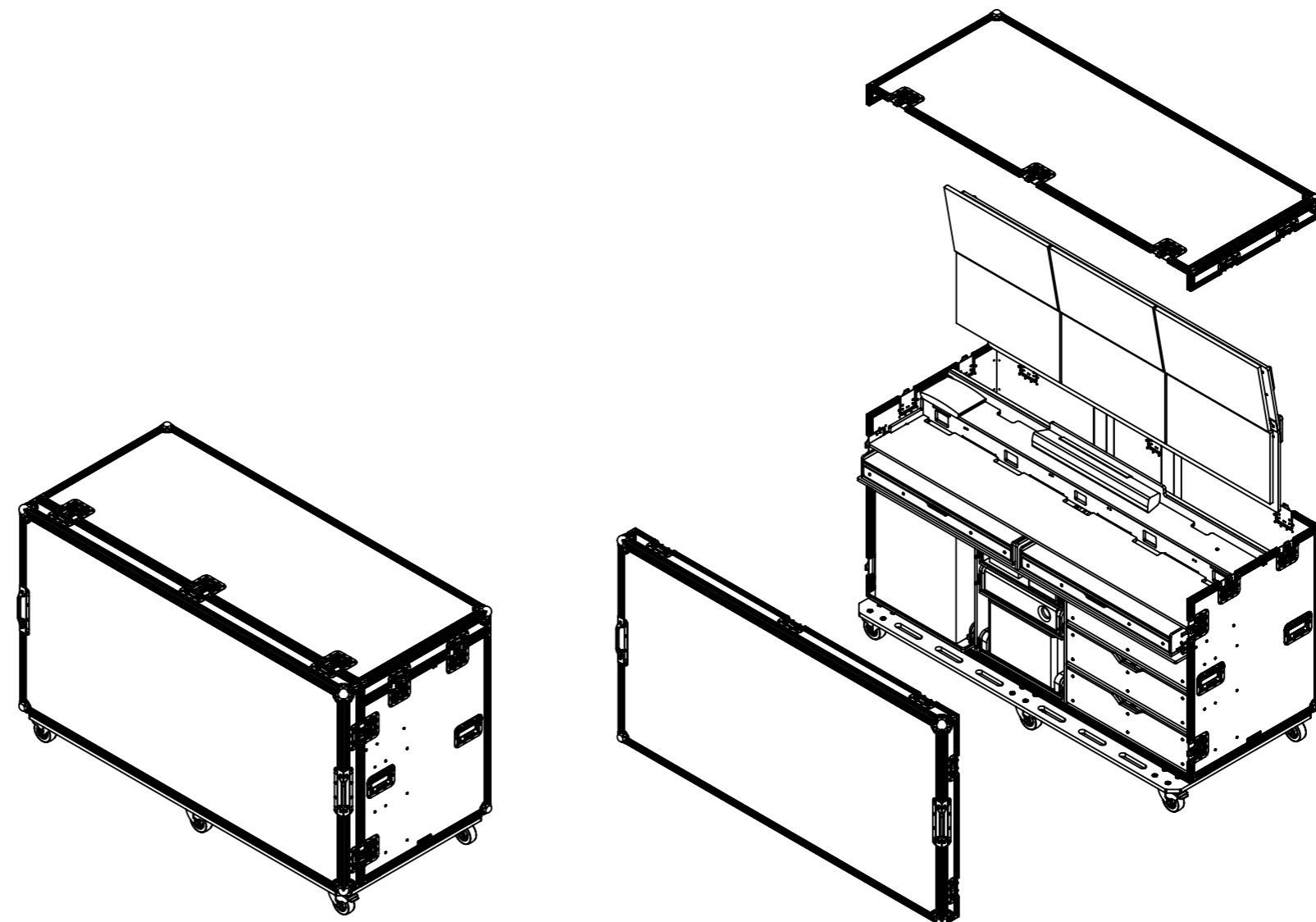
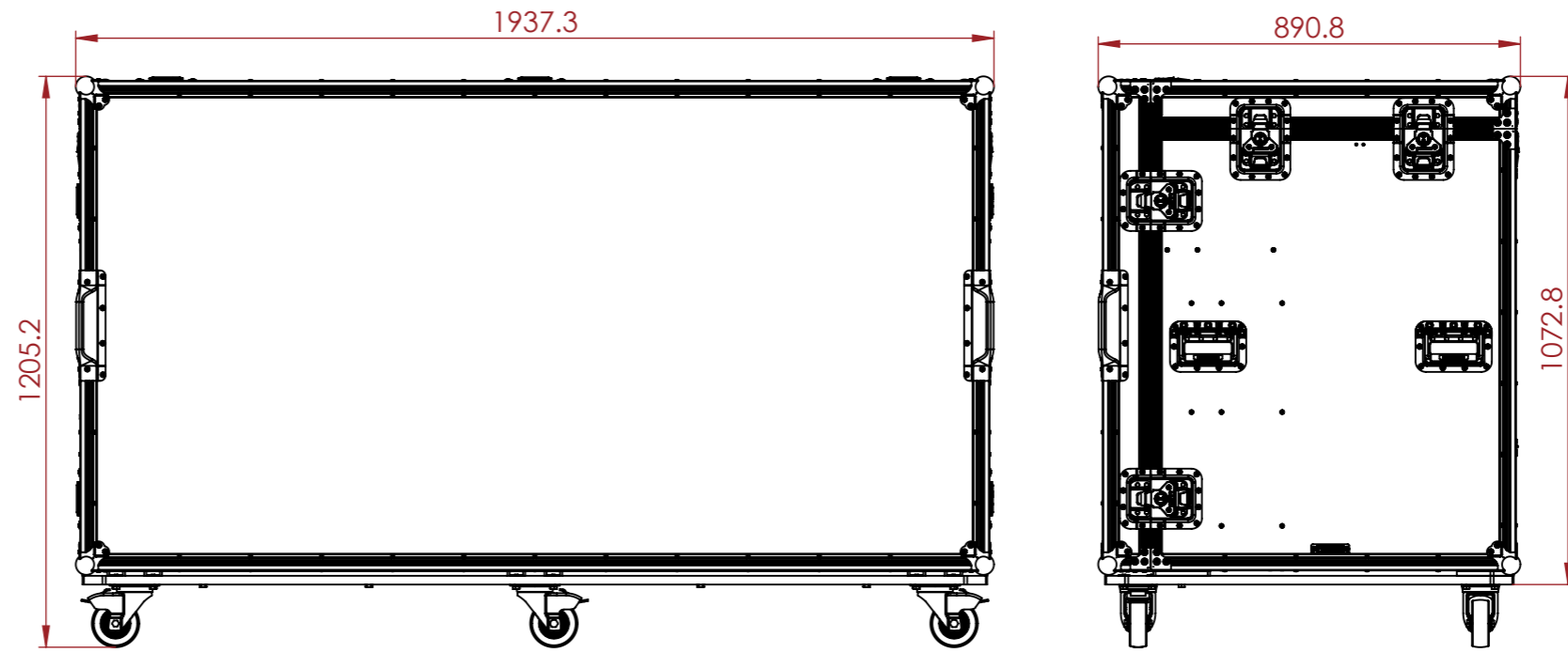

NOTES:

UNLESS SPECIFIED IN THE DRAWING, ALL PRODUCTS DISPLAYED IN THIS DRAWING OTHER THAN THE CASE ITSELF IS NOT PART OF OUR PRODUCT OFFERING.

ESTIMATED WEIGHT (CASE ONLY):

317.66 KG

ITEM CODE:

WS-FP3-SL627

DRAWN BY:

K.I

CHECKED BY:

AS

SCALE:

NTS



MAIL : sales@armorcases.com.au
WEB : www.armorcases.com.au