

# PRODUCT FEATURES

## CONSTRUCTION

- 9MM BIRCH VENEER PLYWOOD WITH HPL EXTERIOR FACE AND PVC INTERIOR FACE
- ARMOR HARDWARE

## FEATURES

- STORAGE SPACE FOR 12" VINYL RECORDS
- EASY TO USE LIFT-OFF-LID CASE
- 4X MEDIUM LATCHES
- 2X RECESSED HANDLES

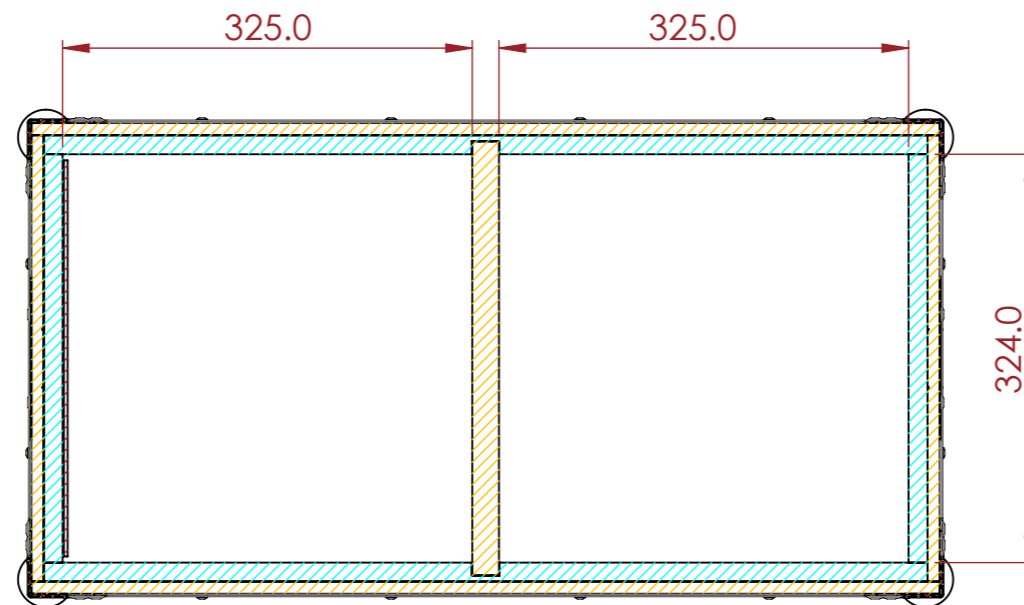
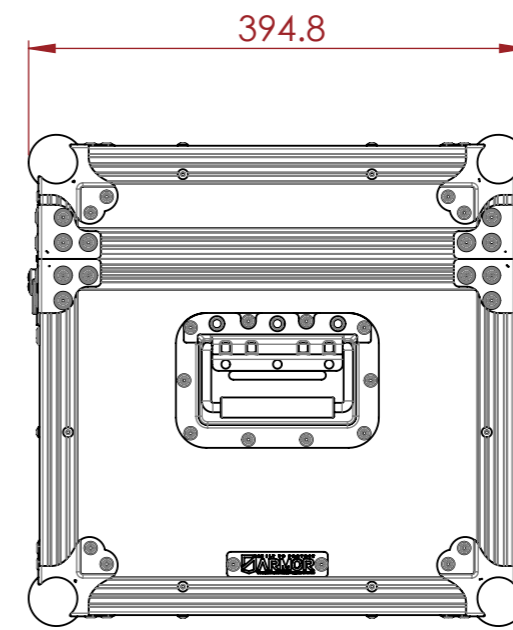
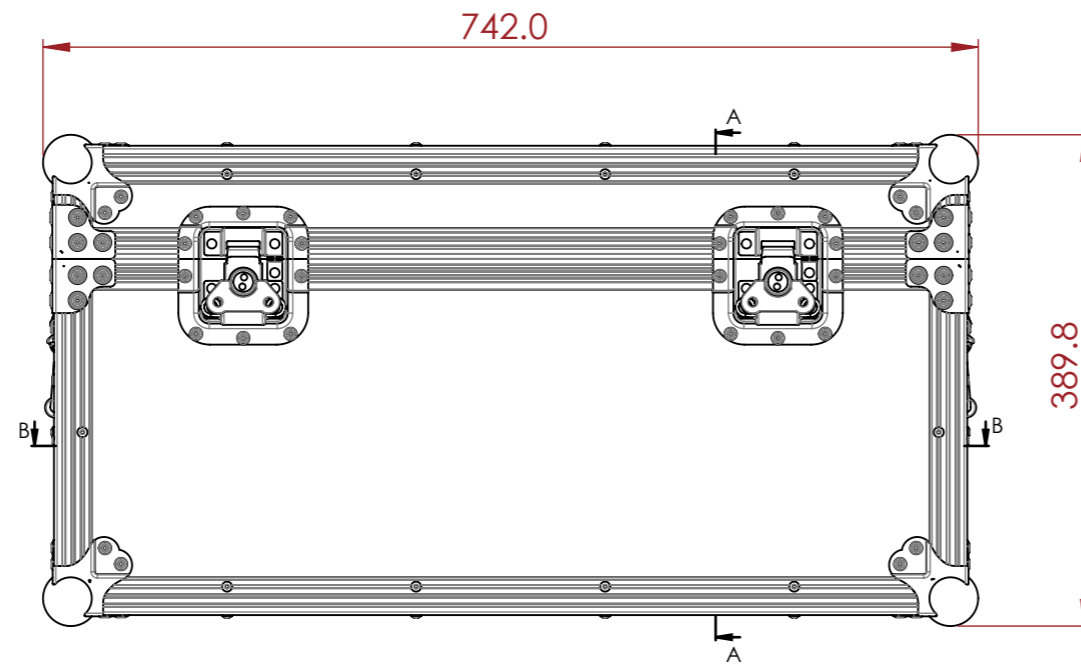

SECTION B-B

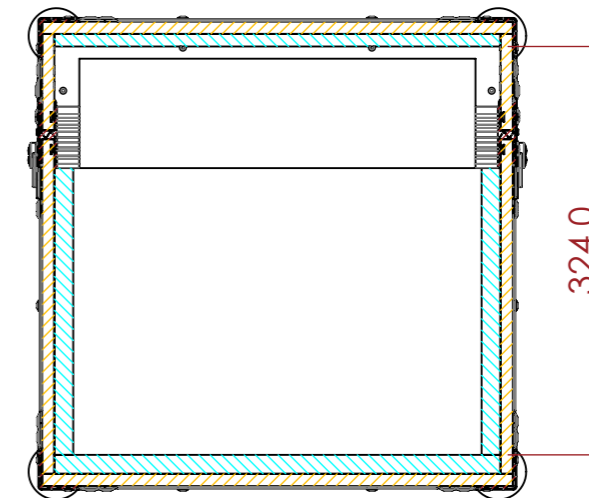

SECTION A-A

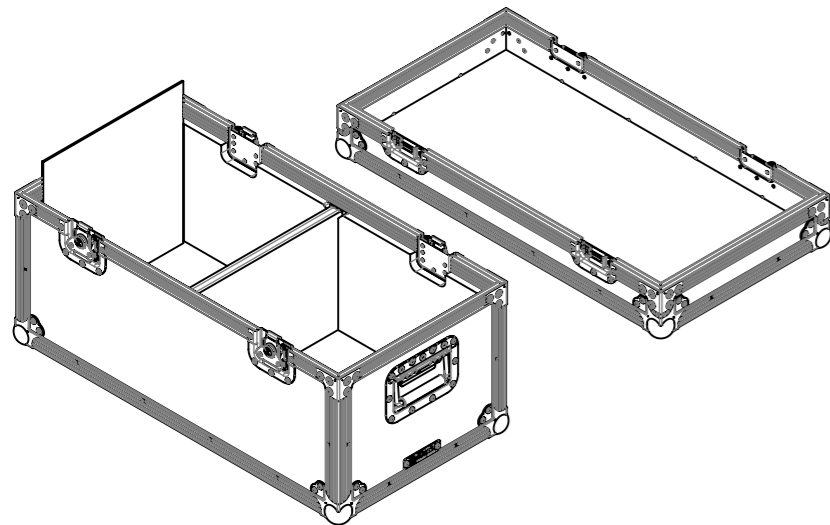
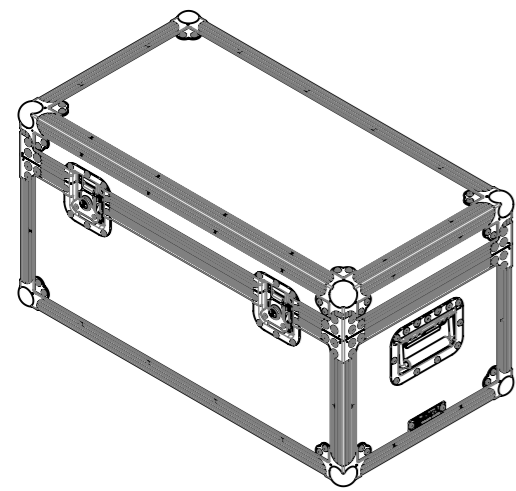

NOTES:  
UNLESS SPECIFIED IN THE DRAWING,  
ALL PRODUCTS DISPLAYED IN THIS  
DRAWING OTHER THAN THE CASE  
ITSELF IS NOT PART OF OUR PRODUCT  
OFFERING.

ESTIMATED WEIGHT (CASE ONLY):

15.87 KG

ITEM CODE:

LOL-LP12-200

DRAWN BY:

K.I

CHECKED BY:

AS

SCALE:

NTS



MAIL : [sales@armorcases.com.au](mailto:sales@armorcases.com.au)  
WEB : [www.armorcases.com.au](http://www.armorcases.com.au)