

PRODUCT FEATURES

CONSTRUCTION

- 12MM BIRCH VENEER PLYWOOD WITH HPL EXTERIOR FACE AND PVC INTERIOR FACE
- ARMOR HARDWARE

INSTALLED EQUIPMENT(NOT INCLUDED)

- 2X SAMSUNG 75" QE75T (LH75QETEPGCXXY)

FEATURES

- FOAM AND 18MM PLYWOOD STRUCTURE DESIGNED TO PROVIDE STABLE AND SECURE SUPPORT FOR TELEVISIONS
- 2X FABRIC BAGS TO STORE ACCESSORIES
- CASE DIMENSIONS ALLOW ACCOMMODATION OF SIMILAR TV SIZES FOR POTENTIAL REUSE
- REMOVABLE LID

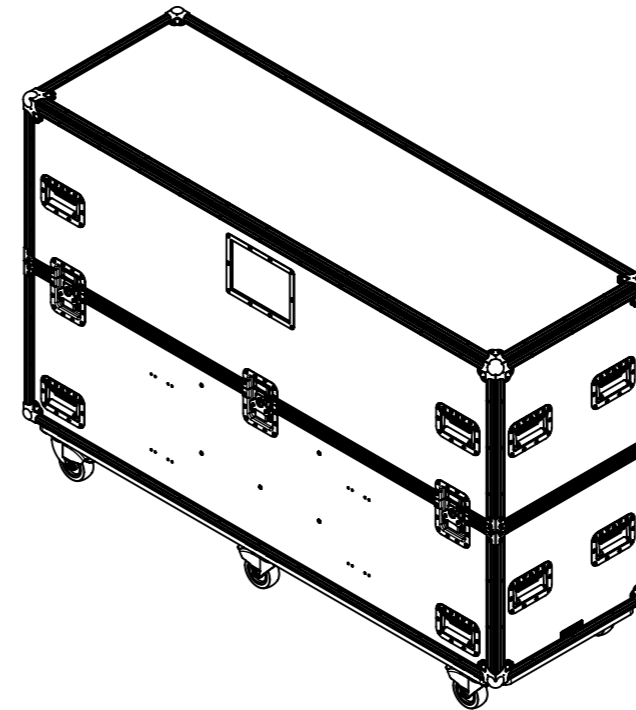
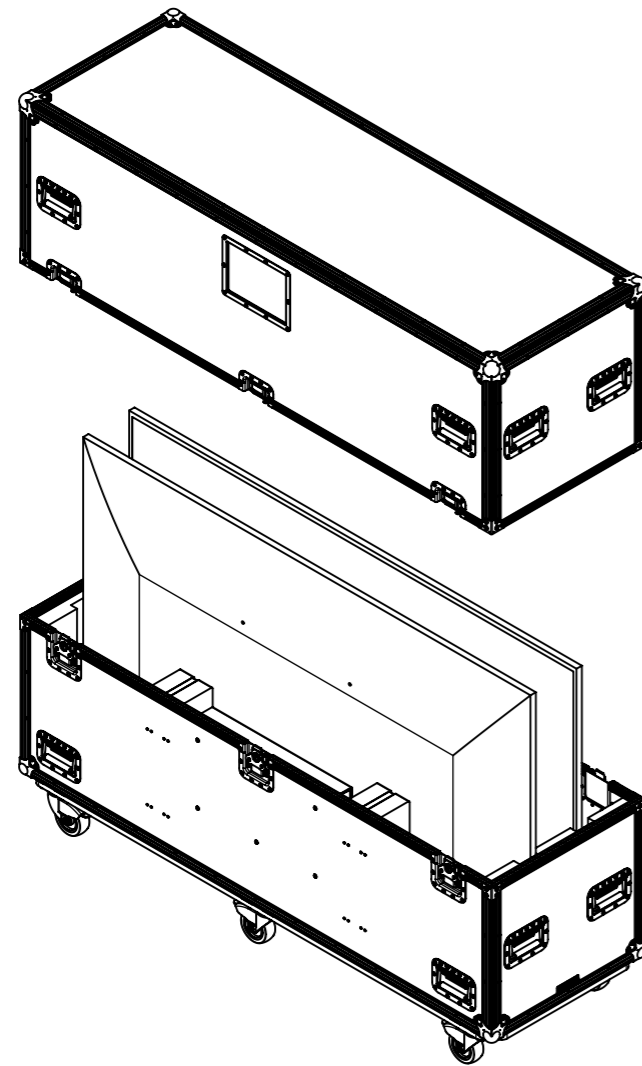
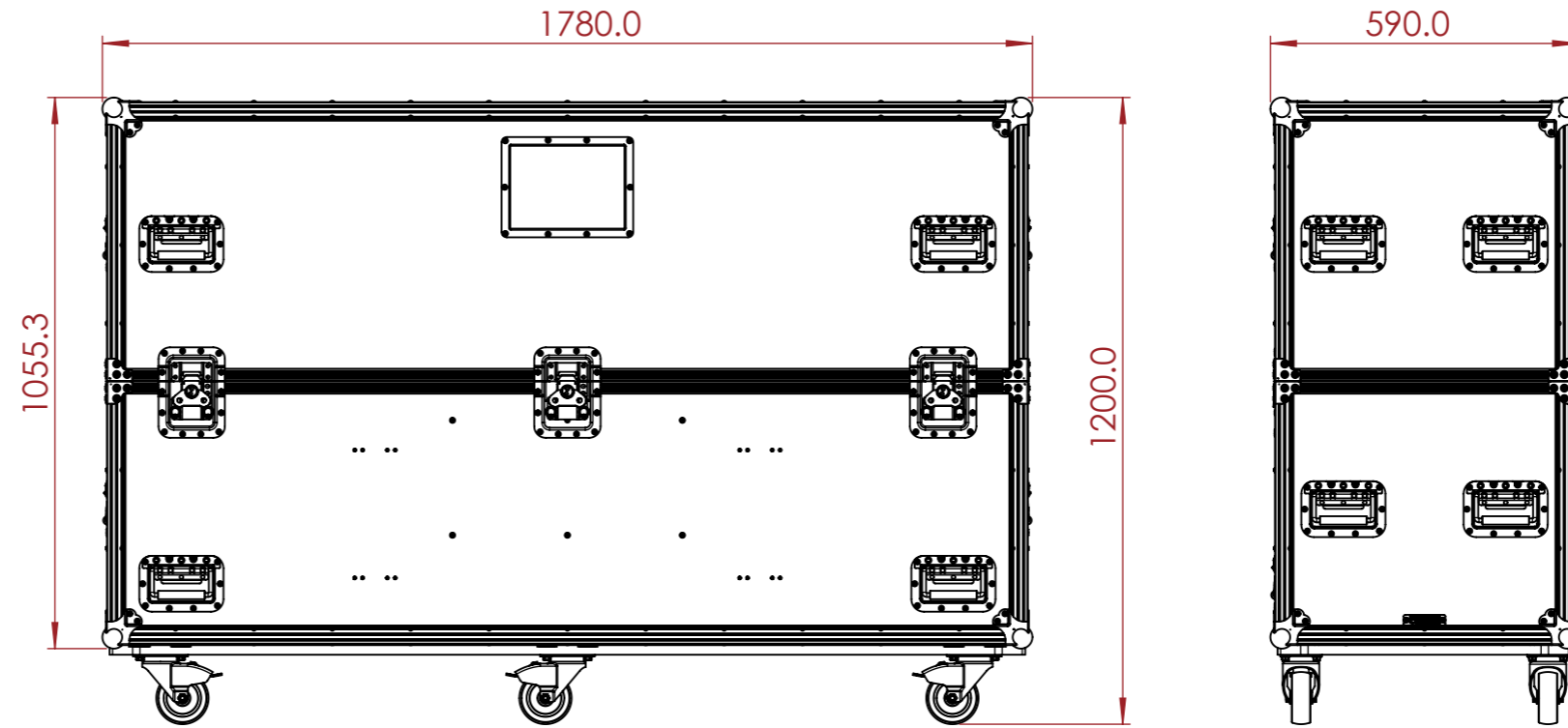

NOTES:
UNLESS SPECIFIED IN THE DRAWING,
ALL PRODUCTS DISPLAYED IN THIS
DRAWING OTHER THAN THE CASE
ITSELF IS NOT PART OF OUR PRODUCT
OFFERING.

ESTIMATED WEIGHT (CASE ONLY):

102.9 KG

ITEM CODE:

TV-75D-SS-QE75T

DRAWN BY:

RP

CHECKED BY:

AS

SCALE:

NTS



MAIL : sales@armorcases.com.au
WEB : www.armorcases.com.au