

SECTION A-A

PRODUCT FEATURES

CONSTRUCTION

- 9MM HIGH QUALITY PLYWOOD PANEL
- ALUMINIUM EXTRUSIONS
- PENN ELCOM HARDWARE
- EVA FOAM
- STEEL BALL CORNERS

FEATURES

- DEDICATED SPACE FOR RIGTEC X30 FRAME, ATOM GRIP, LENS AND ADDITIONAL ACCESSORIES
- BRAKED CASTOR WHEELS
- EASY TO LIFT LID
- CASTOR DISHES FOR STACKING

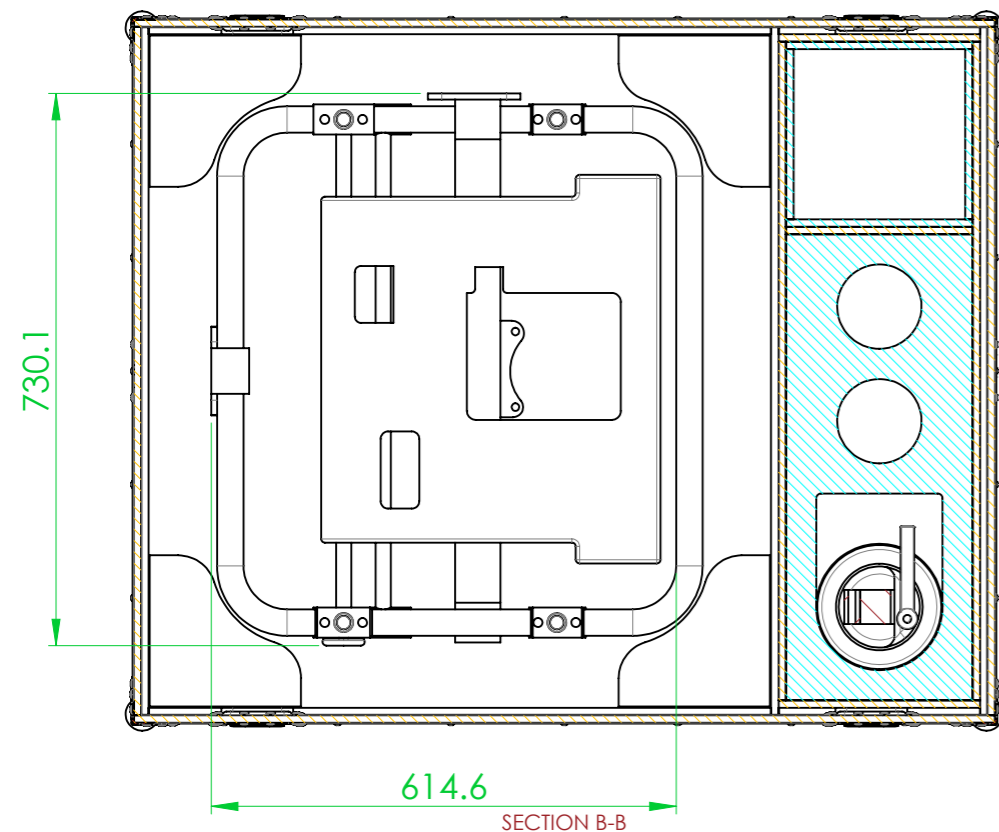

SECTION B-B

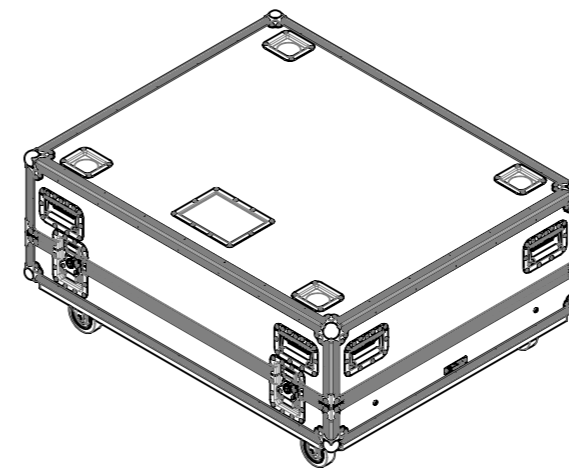

PJTR-RIGTEC-X30-EXT-SA30-1

Atom Grip Standard

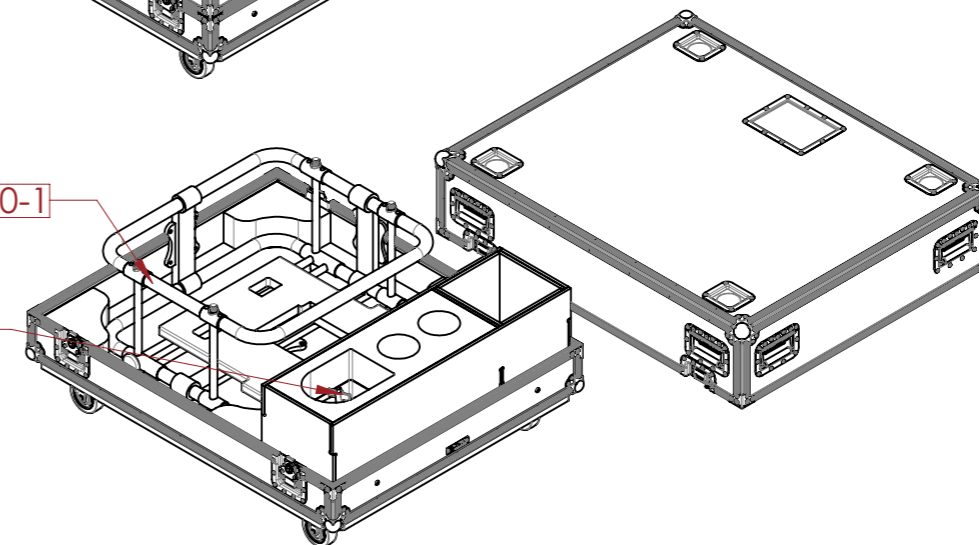

NOTES:
UNLESS SPECIFIED IN THE DRAWING,
ALL PRODUCTS DISPLAYED IN THIS
DRAWING OTHER THAN THE CASE
ITSELF IS NOT PART OF OUR PRODUCT
OFFERING.

ESTIMATED WEIGHT (CASE ONLY):

61.62 KG

ITEM CODE:

PJTR-RIGTEC-X30

DRAWN BY:

HA

CHECKED BY:

AS

SCALE:

NTS



MAIL : sales@armorcases.com.au
WEB : www.armorcases.com.au