

PRODUCT FEATURES

**CONSTRUCTION**

- 12MM BIRCH VENEER PLYWOOD WITH HPL EXTERIOR FACE AND PVC INTERIOR FACE
- PENN ELCOM HARDWARE

**FEATURES**

- STORAGE SPACE FOR 4X ZONDA 3FX LIGHTS
- STORAGE FOR CLAMPS, BRACKETS AND ACCESSORIES
- CASTOR DISHES FOR EASE OF STACKING
- LABEL DISH FOR EASE OF RECOGNITION
- 1X CORNER HANDLE
- 8X RECESSED HANDLES
- 2X BRAKED CASTORS
- 2X NON-BRAKED CASTORS

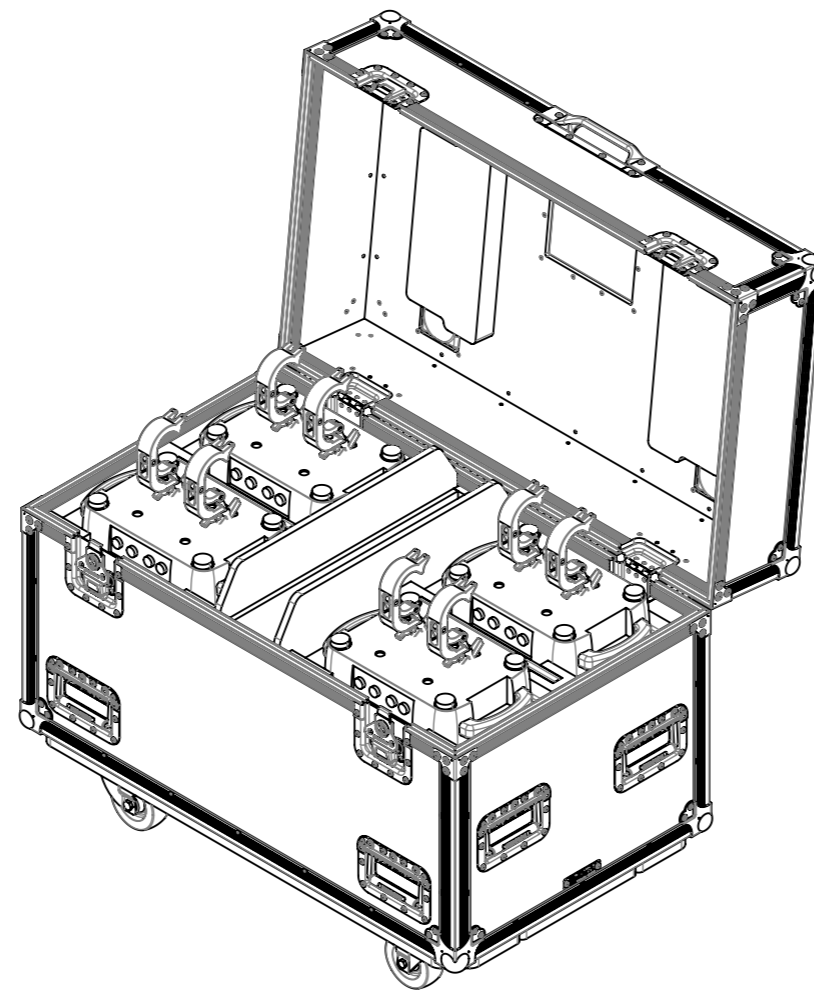
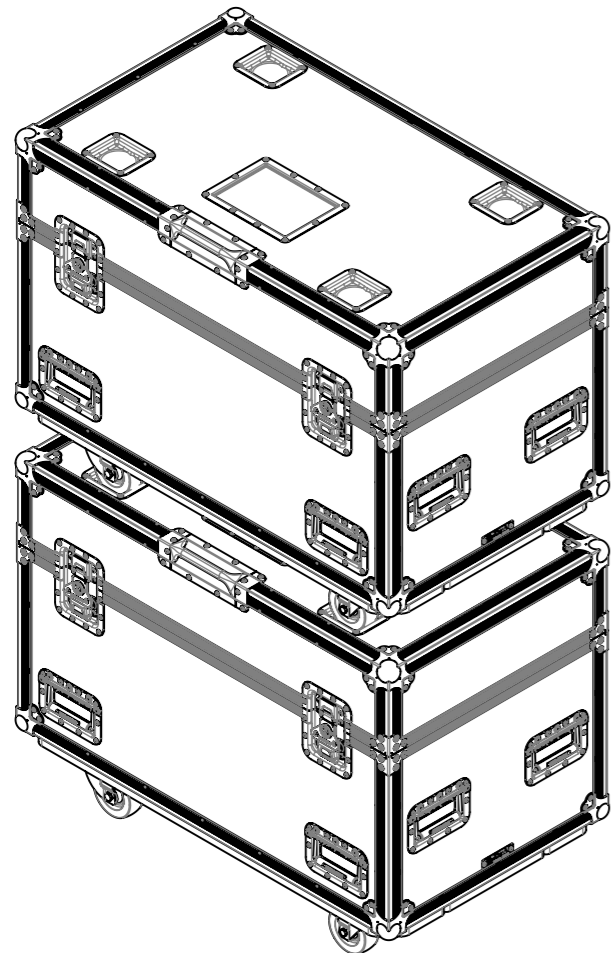
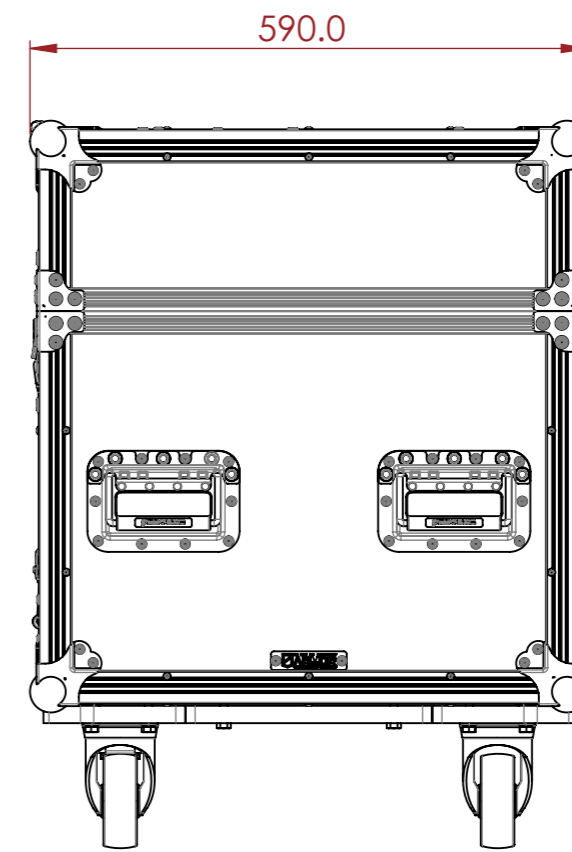
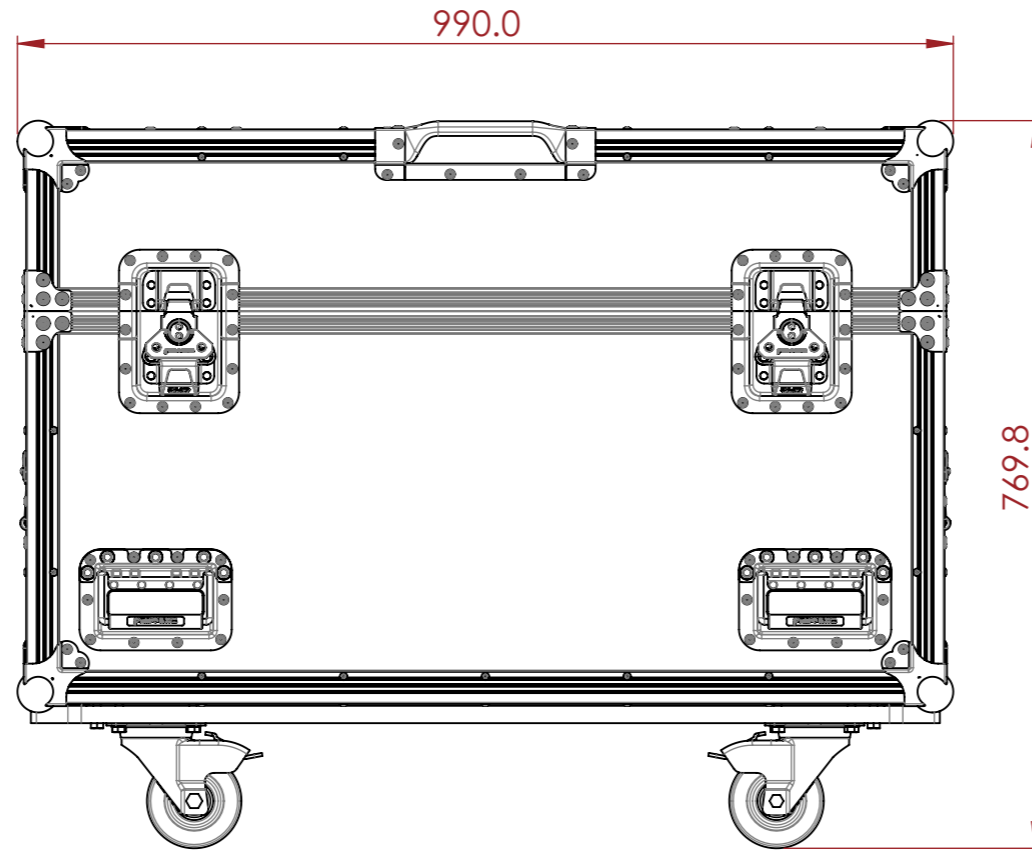

NOTES:  
UNLESS SPECIFIED IN THE DRAWING,  
ALL PRODUCTS DISPLAYED IN THIS  
DRAWING OTHER THAN THE CASE  
ITSELF IS NOT PART OF OUR PRODUCT  
OFFERING.

ESTIMATED WEIGHT (CASE ONLY):  
59.27 KG

ITEM CODE:  
LXMH-ARYTON-ZFX

DRAWN BY: K.I. CHECKED BY: AS

SCALE:  
NTS



MAIL : [sales@armorcases.com.au](mailto:sales@armorcases.com.au)  
WEB : [www.armorcases.com.au](http://www.armorcases.com.au)