

NOTES:  
UNLESS SPECIFIED IN THE DRAWING,  
ALL PRODUCTS DISPLAYED IN THIS  
DRAWING OTHER THAN THE CASE  
ITSELF IS NOT PART OF OUR PRODUCT  
OFFERING.

## PRODUCT FEATURES

### CONSTRUCTION

- 12MM BIRCH VENEER PLYWOOD WITH HPL EXTERIOR FACE AND PVC INTERIOR FACE
- 2X ERGONOMICALLY PLACED HANDLES FOR LIFTING AND TRANSPORTING
- 2X MEDIUM LATCHES
- EVA 38B FOAM PROTECTION
- 1X MEDIUM LABEL DISH

### FEATURES

- DEDICATED SPACE FOR CHAMSYS QUICK Q\_20
- GENERAL STORAGE SPACE FOR ACCESSORIES
- COMPACT DESIGN

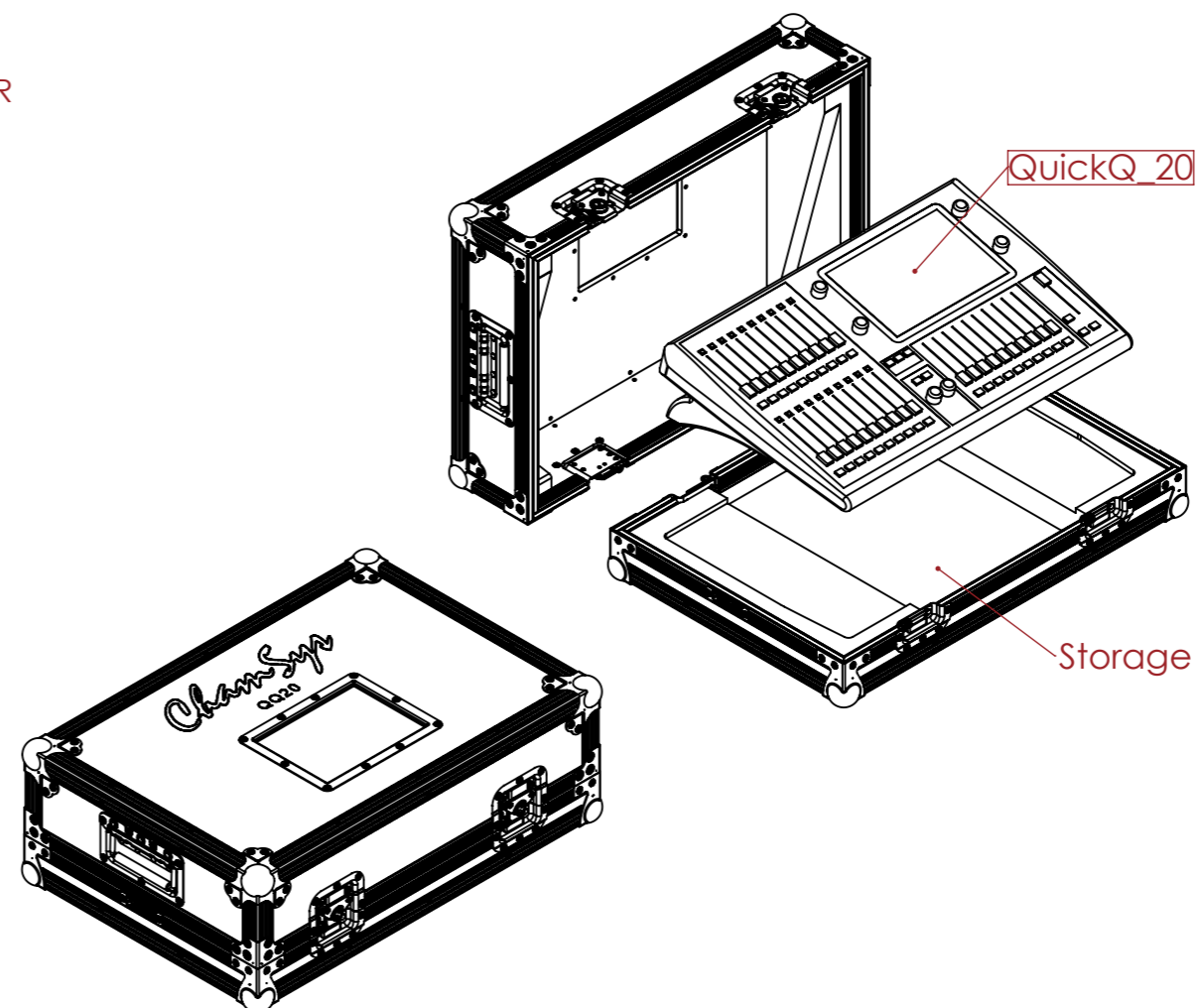

ESTIMATED WEIGHT (CASE ONLY):

12.96 KG

ITEM CODE:

LXCTRL-CMS-QQ20

DRAWN BY:

H.A

CHECKED BY:

AS

SCALE:

NTS



MAIL : [sales@armorcases.com.au](mailto:sales@armorcases.com.au)  
WEB : [www.armorcases.com.au](http://www.armorcases.com.au)