

PRODUCT FEATURES

CONSTRUCTION

- 12MM BIRCH VENEER PLYWOOD WITH HPL EXTERIOR FACE AND PVC INTERIOR FACE
- PENN ELCOM HARDWARE

INSTALLED EQUIPMENT (INCLUDED)

- 2X LARGE RECESSED HANDLES
- 4X LARGE LATCHES
- 4X 75mm CASTORS 2X BRAKED

FEATURES

- LIFT OFF LID DESIGN
- GENERAL STORAGE FOR ACCESSORIES UNDER THE AMPLIFIER

KEY MEASUREMENTS

- 65mm HEIGHT OF STORAGE UNDER THE AMPLIFIER

DESIGN SPECIFICATIONS

- TRUCK FRIENDLY DIMENISONS

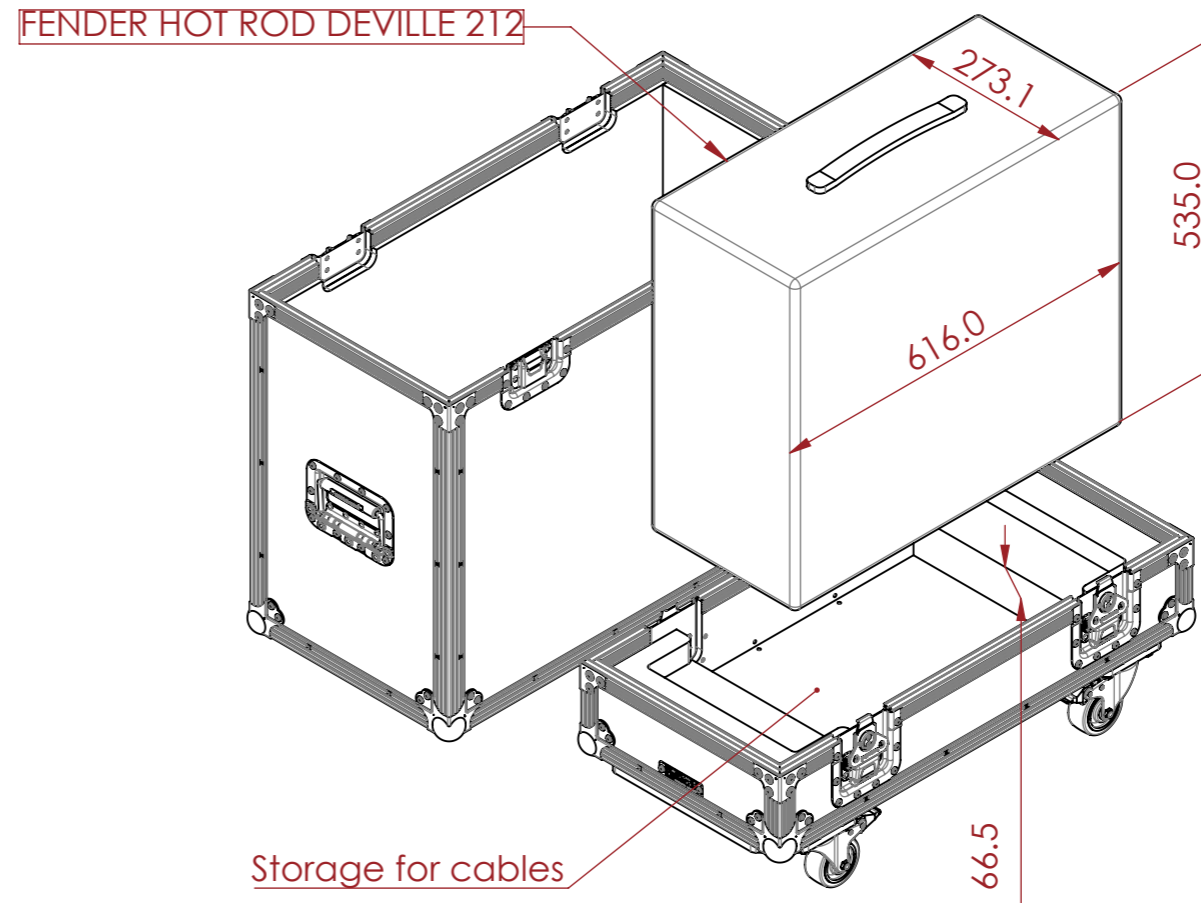
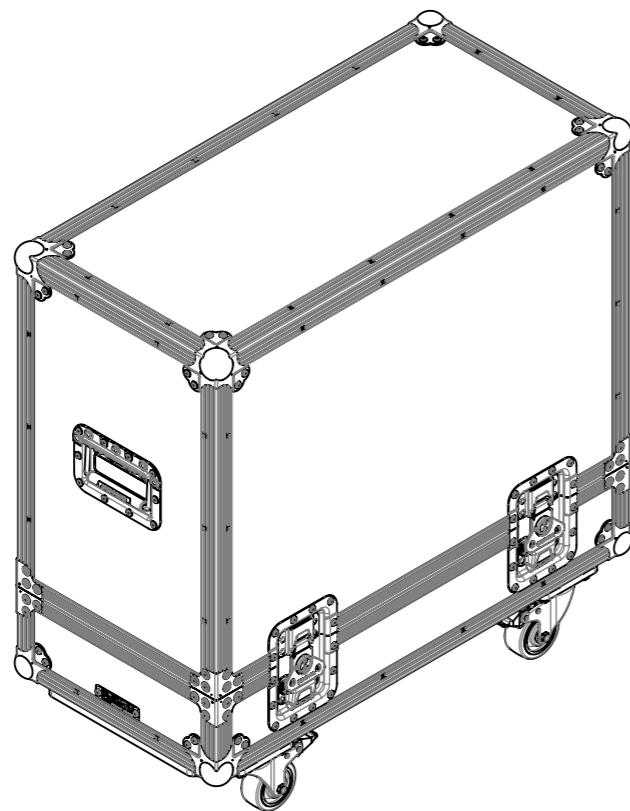
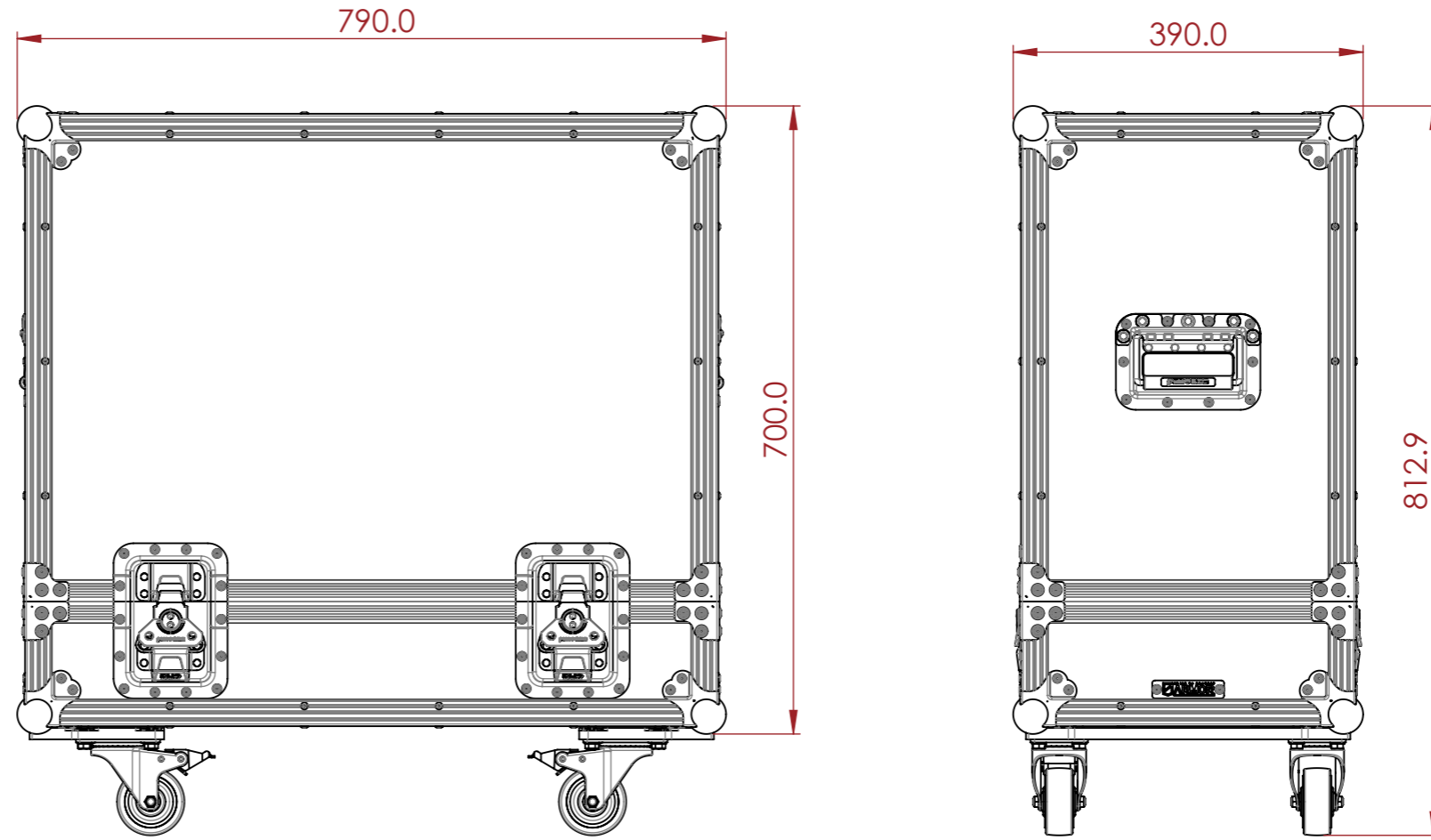

NOTES:

UNLESS SPECIFIED IN THE DRAWING, ALL PRODUCTS DISPLAYED IN THIS DRAWING OTHER THAN THE CASE ITSELF IS NOT PART OF OUR PRODUCT OFFERING.

ESTIMATED WEIGHT (CASE ONLY):

29.6 KG

ITEM CODE:

AMP8470-FNDR-HRD212

DRAWN BY:

HA

CHECKED BY:

AS

SCALE:

NTS



MAIL : sales@armorcases.com.au
 WEB : www.armorcases.com.au