

# PRODUCT FEATURES

## CONSTRUCTION

- 12MM BIRCH VENEER PLYWOOD WITH HPL EXTERIOR FACE AND PVC INTERIOR FACE
- ARMOR HARDWARE

## FEATURES

- DEDICATED SPACE FOR 2X SONY KD-55X80L
- STORAGE SPACE : 225.8 x 423.2 x 793.2 mm
- EASY TO USE LIFT-OFF-LID DESIGN
- TRUCK FRIENDLY DIMENSIONS
- 3X BRAKED , 3X NON BRAKED CASTORS
- 6X LARGE LATCHES
- 12X MEDIUM RECESSED HANDLES

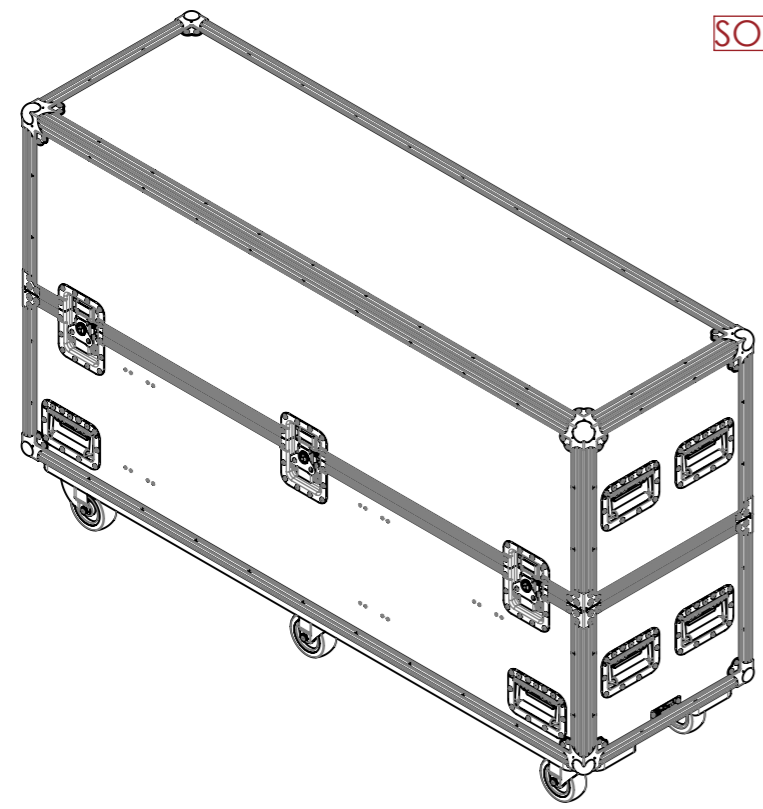
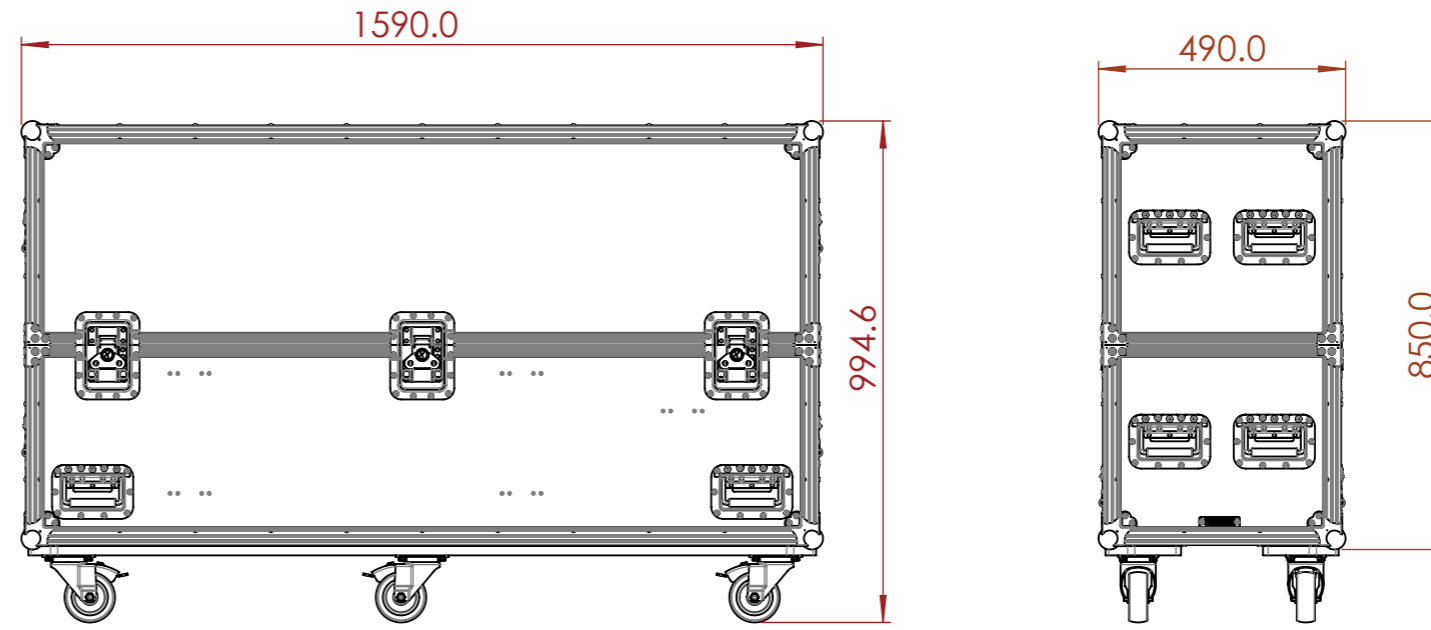

SONY KD-55X80L

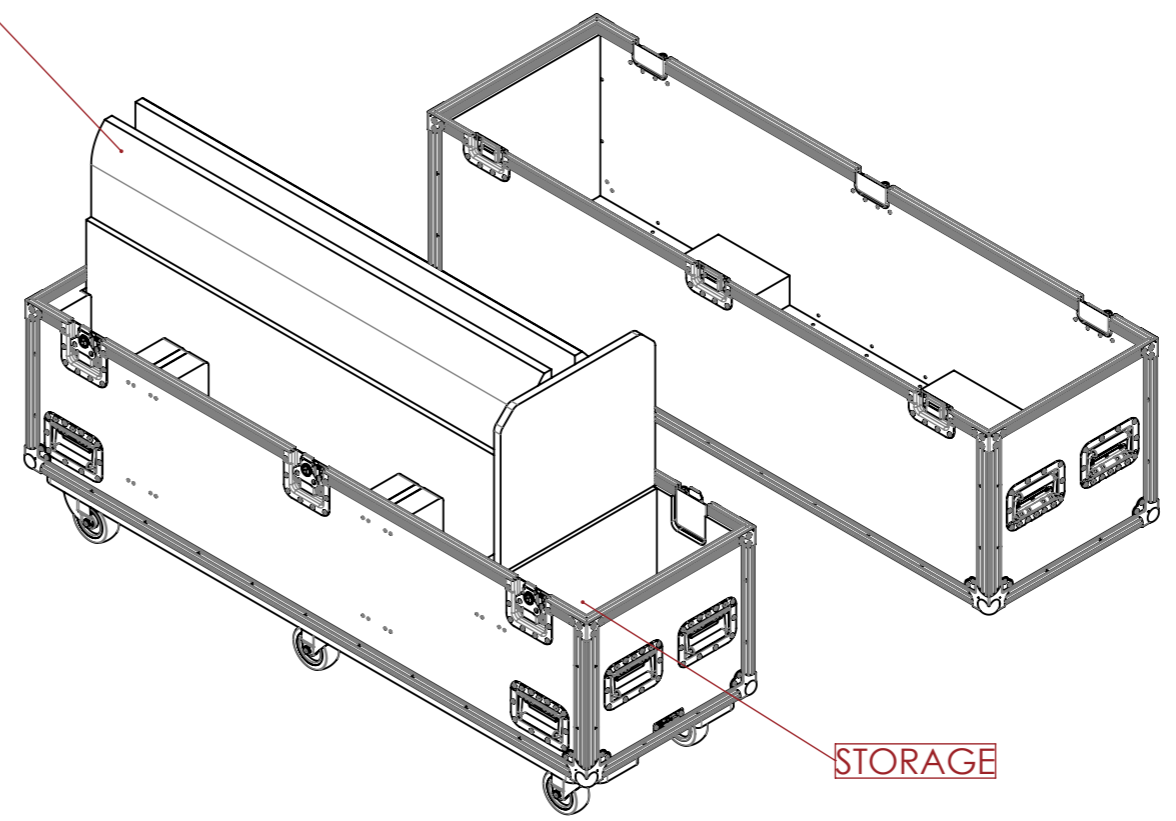

STORAGE

NOTES:  
UNLESS SPECIFIED IN THE DRAWING,  
ALL PRODUCTS DISPLAYED IN THIS  
DRAWING OTHER THAN THE CASE  
ITSELF IS NOT PART OF OUR PRODUCT  
OFFERING.

ESTIMATED WEIGHT (CASE ONLY):

76.8 KG

ITEM CODE:

TV-55D-SNY-KDX80L

DRAWN BY:

HA

CHECKED BY:

AS

SCALE:

NTS



MAIL : [sales@armorcases.com.au](mailto:sales@armorcases.com.au)  
WEB : [www.armorcases.com.au](http://www.armorcases.com.au)