

NOTES:  
UNLESS SPECIFIED IN THE DRAWING,  
ALL PRODUCTS DISPLAYED IN THIS  
DRAWING OTHER THAN THE CASE  
ITSELF IS NOT PART OF OUR PRODUCT  
OFFERING.

## PRODUCT FEATURES

### CONSTRUCTION

- 9MM BIRCH VENEER PLYWOOD WITH HPL EXTERIOR FACE AND PVC INTERIOR FACE
- ARMOR HARDWARE.
- 8X ERGONOMICALLY PLACED HANDLES FOR LIFTING AND TRANSPORTING
- LARGE LATCHES
- EVA38B FOAM PROTECTION
- 12MM PAIR CASTOR BOARD
- 4X 75MM CASTORS 2X BRAKED

### FEATURES

- DEDICATED SPACE FOR 2X PHILIPS-32DBL3550Q75
- EASY TO USE LIFT-OFF-LID DESIGN
- TRUCK PACK FRIENDLY DIMENSIONS

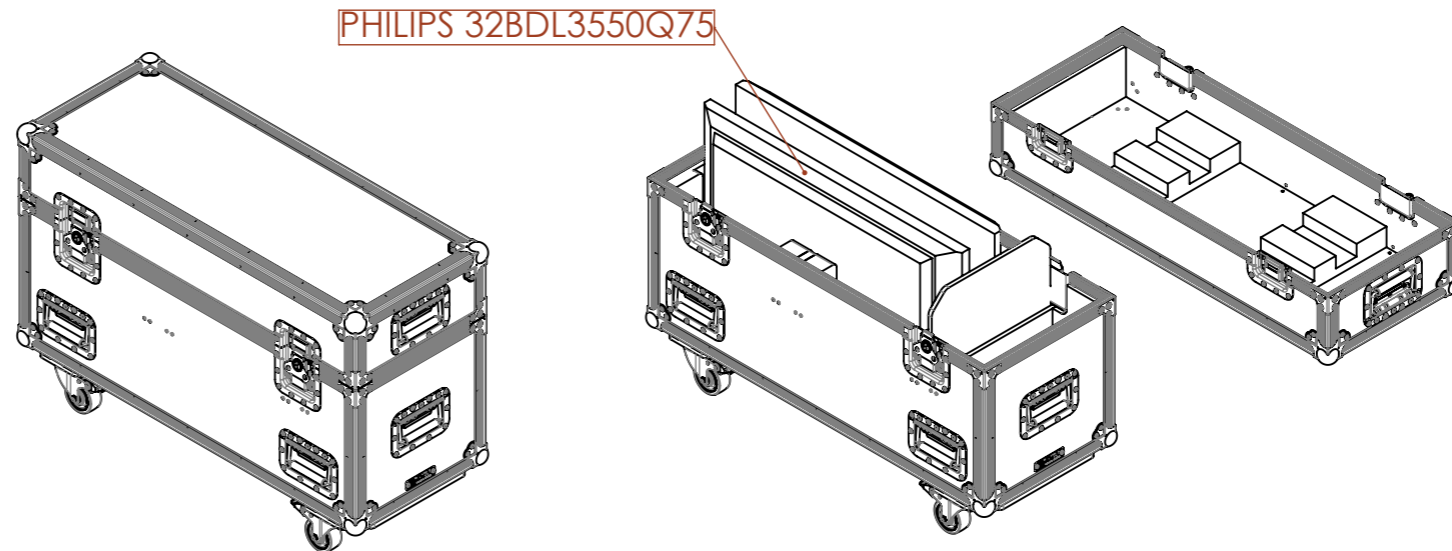

ESTIMATED WEIGHT (CASE ONLY):

27.2 KG

ITEM CODE:

TV-32D-PLP-32BD-HT

DRAWN BY:

HA

CHECKED BY:

AS

SCALE:

NTS



MAIL : [sales@armorcases.com.au](mailto:sales@armorcases.com.au)  
WEB : [www.armorcases.com.au](http://www.armorcases.com.au)