

**PRODUCT FEATURES**

**CONSTRUCTION**

- 9MM BIRCH VENEER PLYWOOD WITH HPL EXTERIOR FACE AND PVC INTERIOR FACE
- ARMOR HARDWARE

**INSTALLED EQUIPMENT (INCLUDED)**

- NONE

**FEATURES**

- NOT APPLICABLE

**KEY MEASUREMENTS**

- HEIGHT OF CASE 558MM

**DESIGN SPECIFICATIONS**

- GENERAL STORAGE SPACE FOR ACCESSORIES
- STORAGE SPACE FOR 3X LENSES

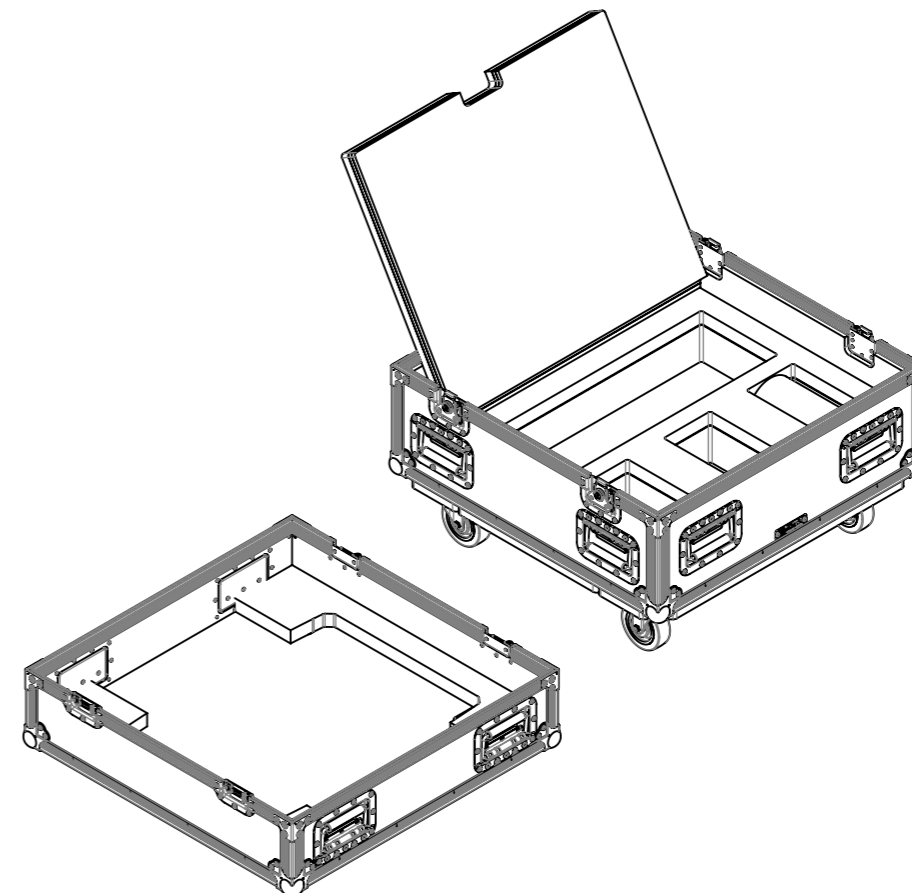
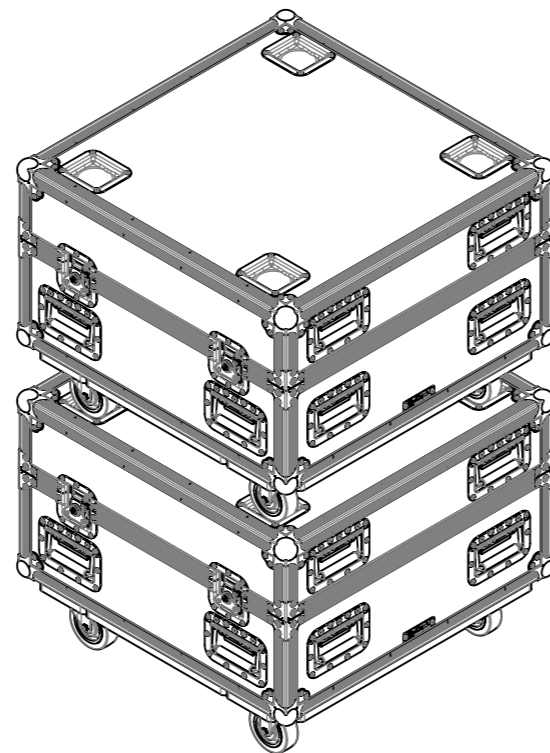
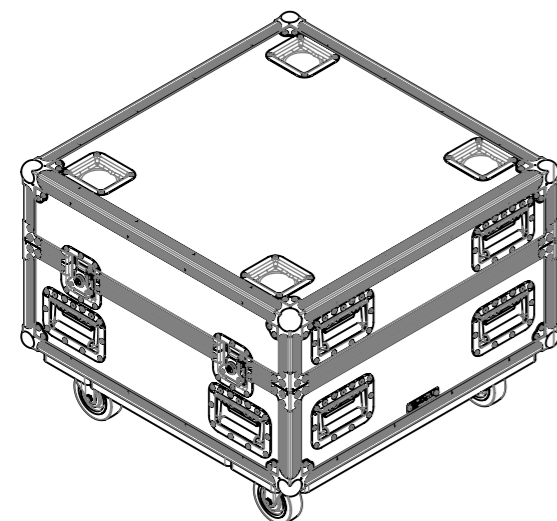
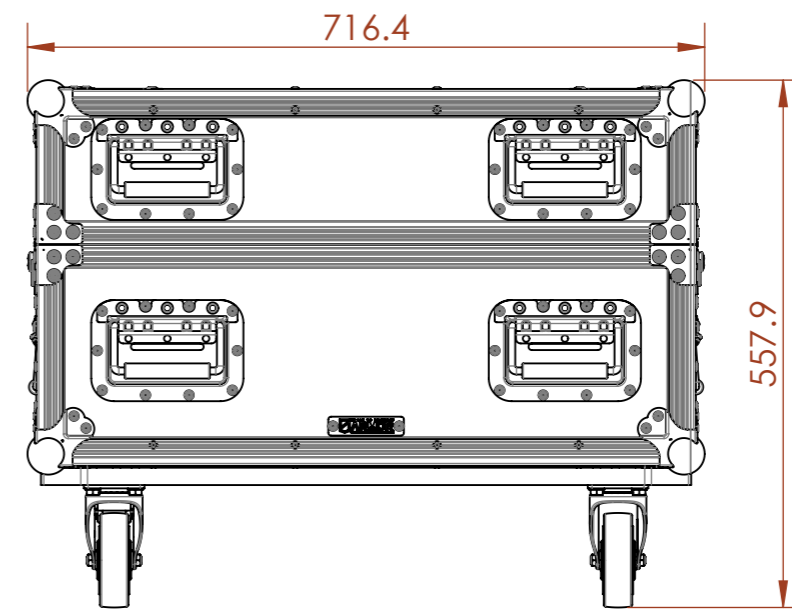
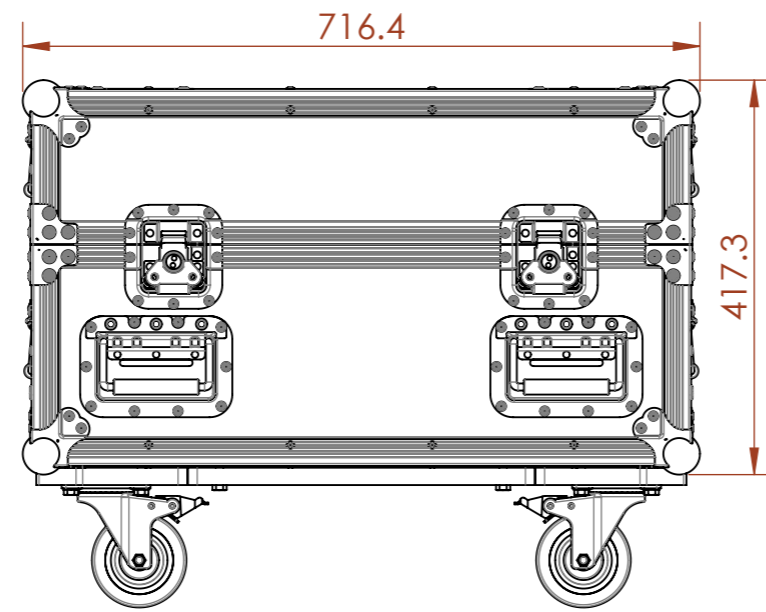

NOTES:  
UNLESS SPECIFIED IN THE DRAWING,  
ALL PRODUCTS DISPLAYED IN THIS  
DRAWING OTHER THAN THE CASE  
ITSELF IS NOT PART OF OUR PRODUCT  
OFFERING.

ESTIMATED WEIGHT (CASE ONLY):

36.2 KG

ITEM CODE:

PJTR-PS-PTMZ570

DRAWN BY:

HA

CHECKED BY:

AS

SCALE:

NTS



MAIL : [sales@armorcases.com.au](mailto:sales@armorcases.com.au)  
WEB : [www.armorcases.com.au](http://www.armorcases.com.au)