

PRODUCT FEATURES

CONSTRUCTION

- 12MM BIRCH VENEER PLYWOOD WITH HPL EXTERIOR FACE AND PVC INTERIOR FACE
- PENN ELCOM HARDWARE

INSTALLED EQUIPMENT (INCLUDED)

- TWO MONITOR VESA ATTACHMENTS, 100 X 100 VESA MOUNTS
- 12RU RACK STRIPS LOCATED AT THE FRONT AND BACK
- FRONT TO BACK RACK STRIP DISTANCE AT 562MM
- 2RU TRAY, 2 X 2RU DRAWER, 3RU DRAWER

FEATURES

- FRONT LID CAN BE SETUP ON THE RIGHT OR LEFT SIDE OF THE WORKSTATION
- SLAM LID LOCATED ON THE BACK
- DUAL POCKETS LOCATED WITH 130MM WIDTH
- PULL OUT DRAWER WITH FLIP OUT PAD
- GAS STRUTS SUPPORTED TOP LID
- FLIP OUT SECOND MONITOR

KEY MEASUREMENTS

- FOLDABLE TABLE TOP HEIGHT 870MM

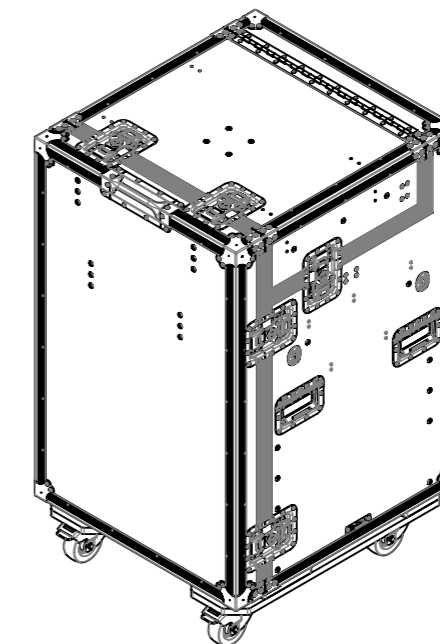
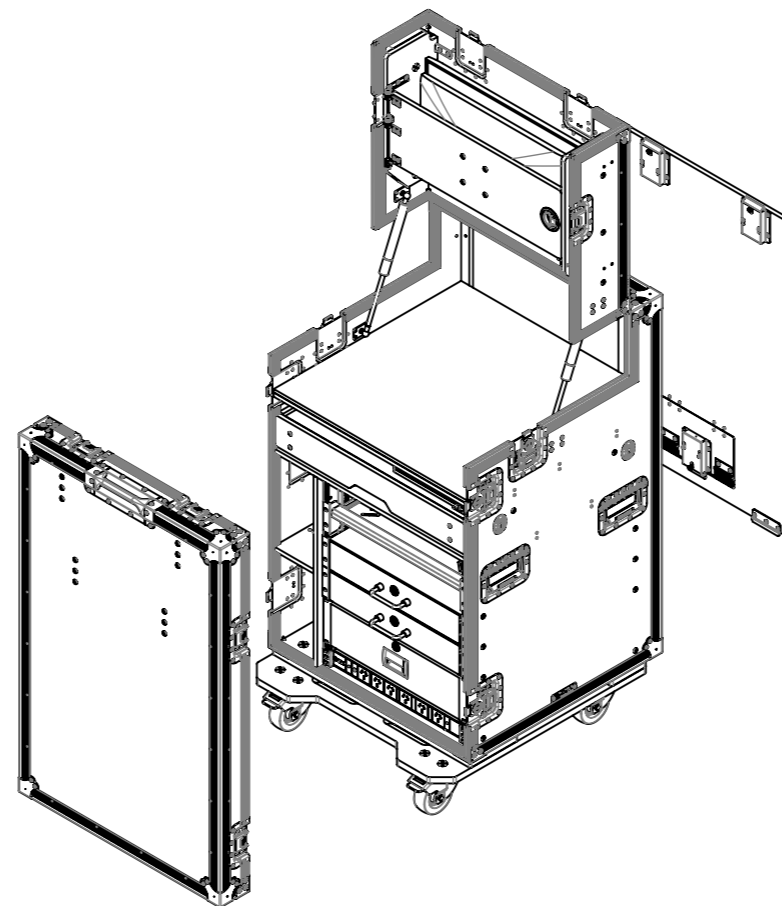
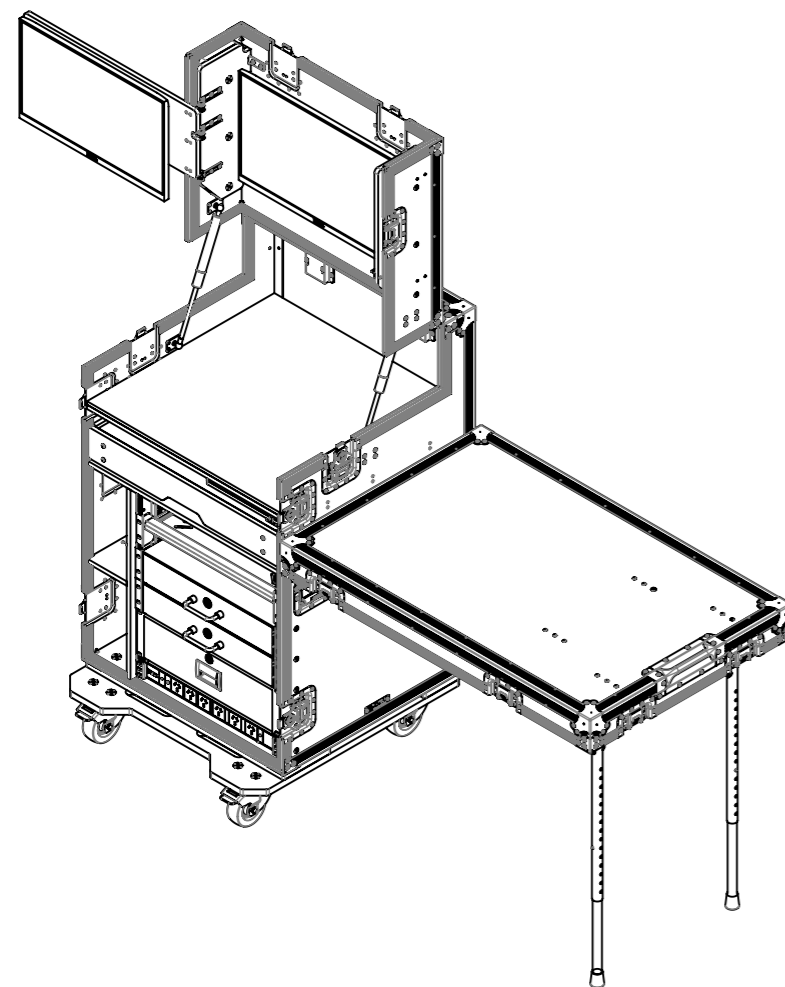
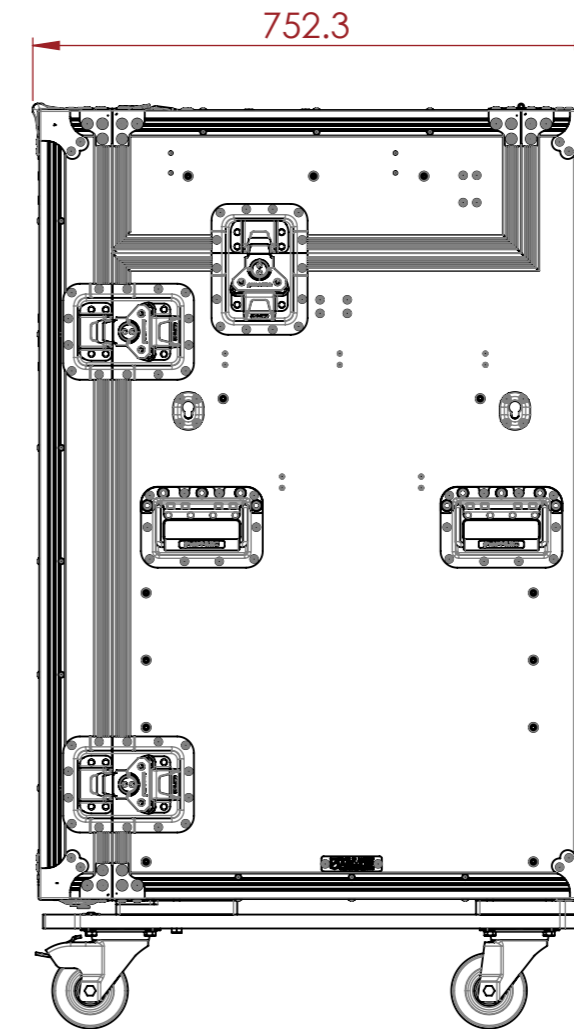
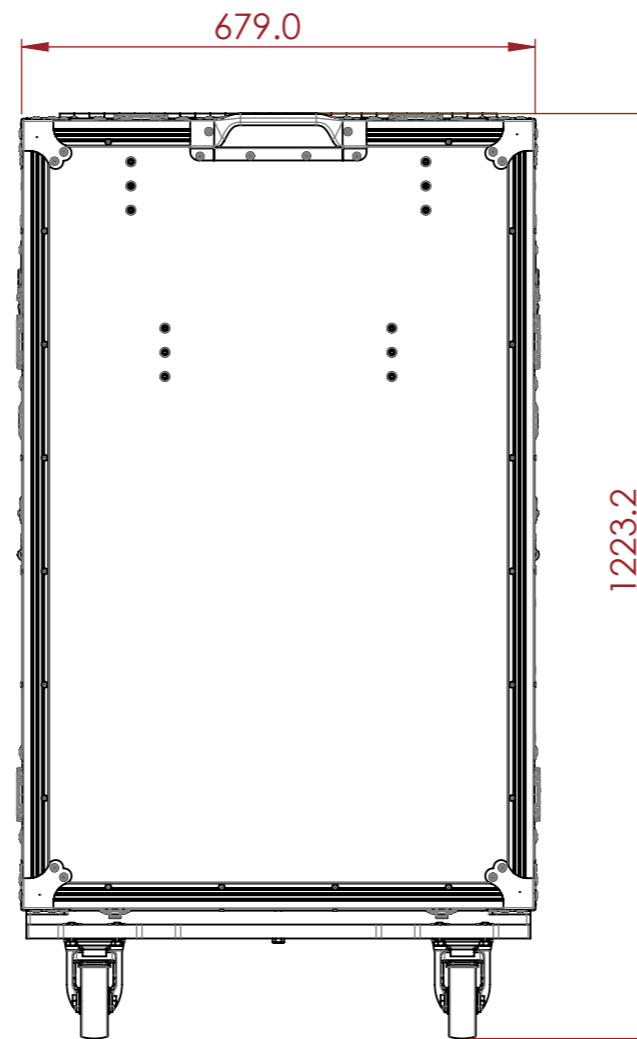

NOTES:

UNLESS SPECIFIED IN THE DRAWING, ALL PRODUCTS DISPLAYED IN THIS DRAWING OTHER THAN THE CASE ITSELF IS NOT PART OF OUR PRODUCT OFFERING.

ESTIMATED WEIGHT (CASE ONLY):

106.83 KG

ITEM CODE:

WS-FP1-RS

DRAWN BY:

K.I

CHECKED BY:

AS

SCALE:

NTS



MAIL : sales@armorcases.com.au
 WEB : www.armorcases.com.au