

# PRODUCT FEATURES

## CONSTRUCTION

- 9MM BIRCH VENEER PLYWOOD WITH HPL EXTERIOR FACE AND PVC INTERIOR FACE
- ARMOR HARDWARE

## INSTALLED EQUIPMENT (INCLUDED)

- 8X DRAWERS
- 6X LARGE RECESSED HANDLES
- 2X LARGE LATCHES
- 4X CASTOR WHEELS 2X BRAKED

## FEATURES

- CARPET LINING IN THE DRAWERS
- CLAMP SHELL DESIGN

## KEY MEASUREMENTS

- SIZE OF POCKET STORAGE 394W X 70D X 135H

## DESIGN SPECIFICATIONS

- 3X POCKET STORAGE IN THE LID WITH 5mm FOAM LINING

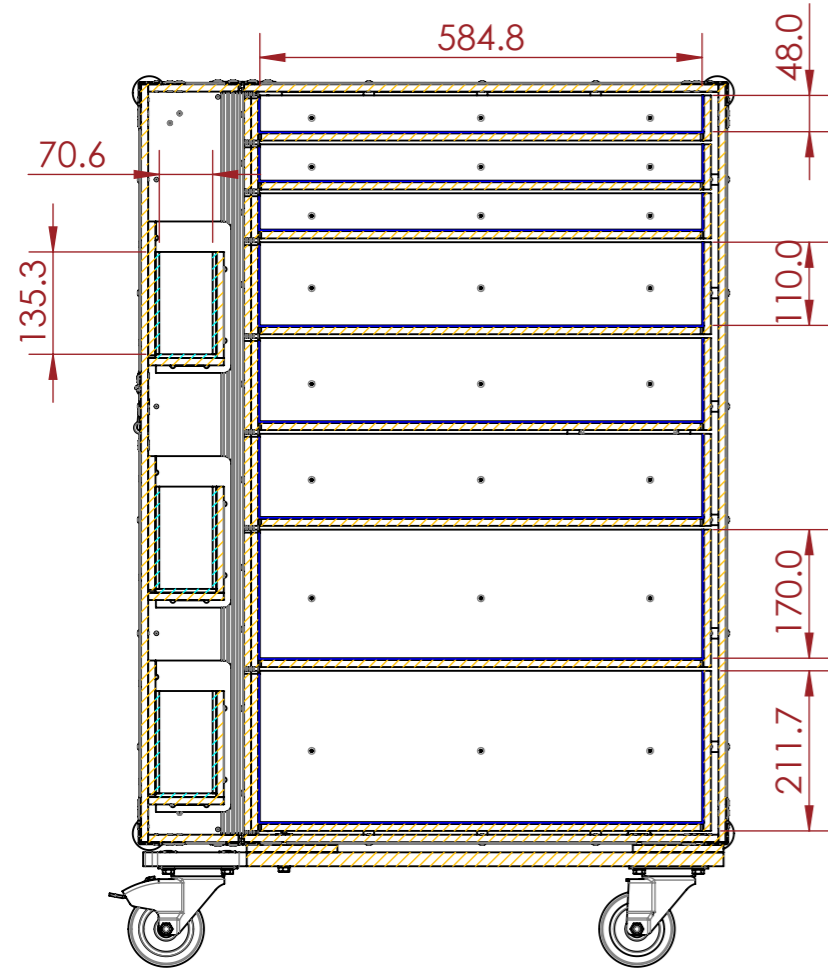
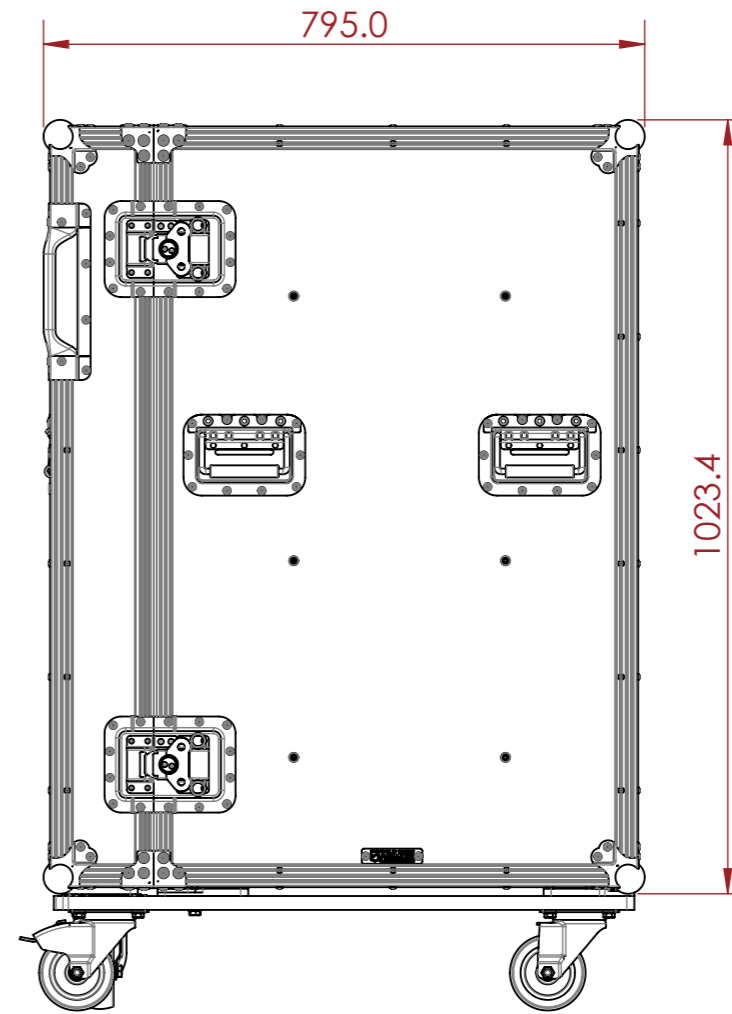
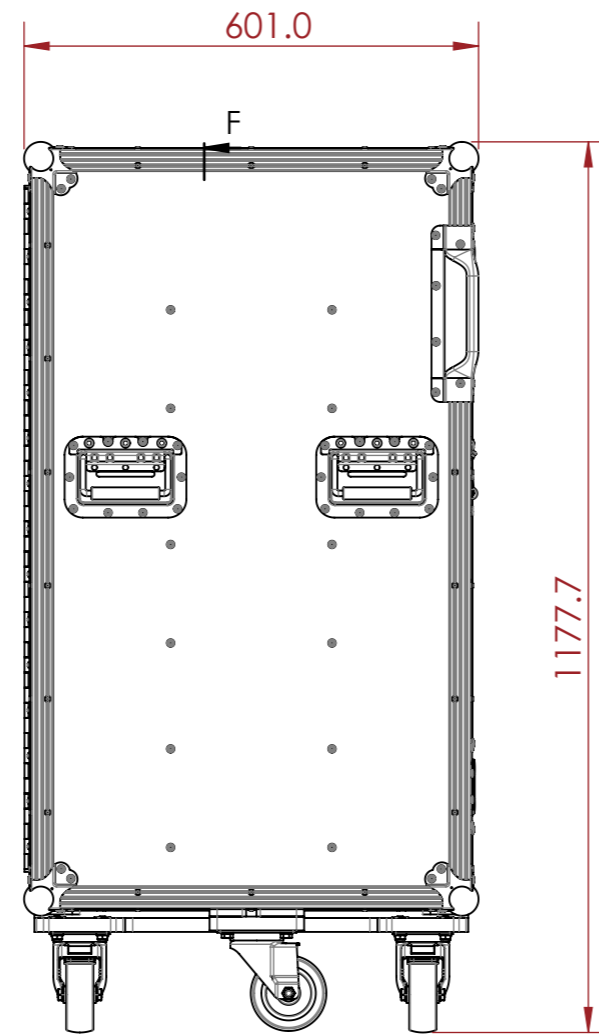

SECTION F-F

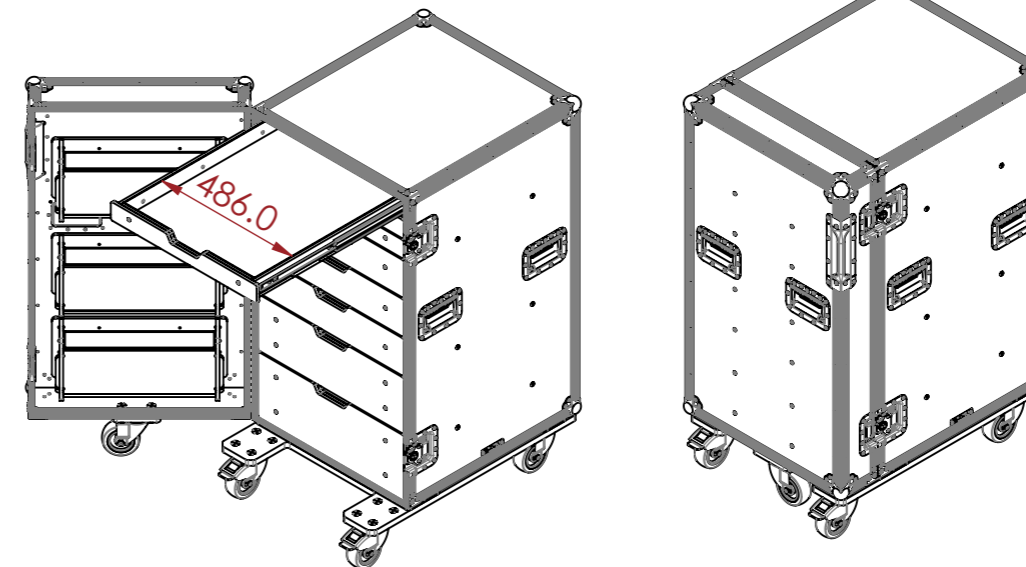

NOTES:  
UNLESS SPECIFIED IN THE DRAWING,  
ALL PRODUCTS DISPLAYED IN THIS  
DRAWING OTHER THAN THE CASE  
ITSELF IS NOT PART OF OUR PRODUCT  
OFFERING.

ESTIMATED WEIGHT (CASE ONLY):

105.20 KG

ITEM CODE:

UTL-DR8

DRAWN BY:

HA

CHECKED BY:

AS

SCALE:

NTS



MAIL : [sales@armorcases.com.au](mailto:sales@armorcases.com.au)  
WEB : [www.armorcases.com.au](http://www.armorcases.com.au)