

CUSTOMER NAME:

QTY IN THIS BATCH:



BUILT BY:

DUE DATE:

MAIL : sales@armorcases.com.au
WEB : www.armorcases.com.au

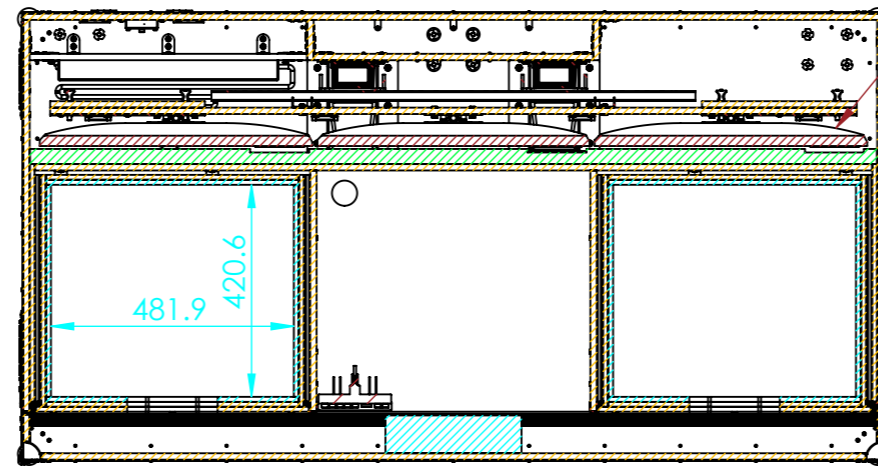
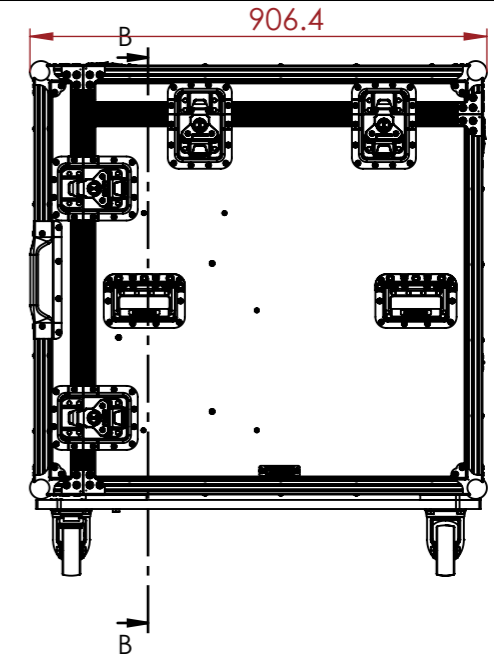
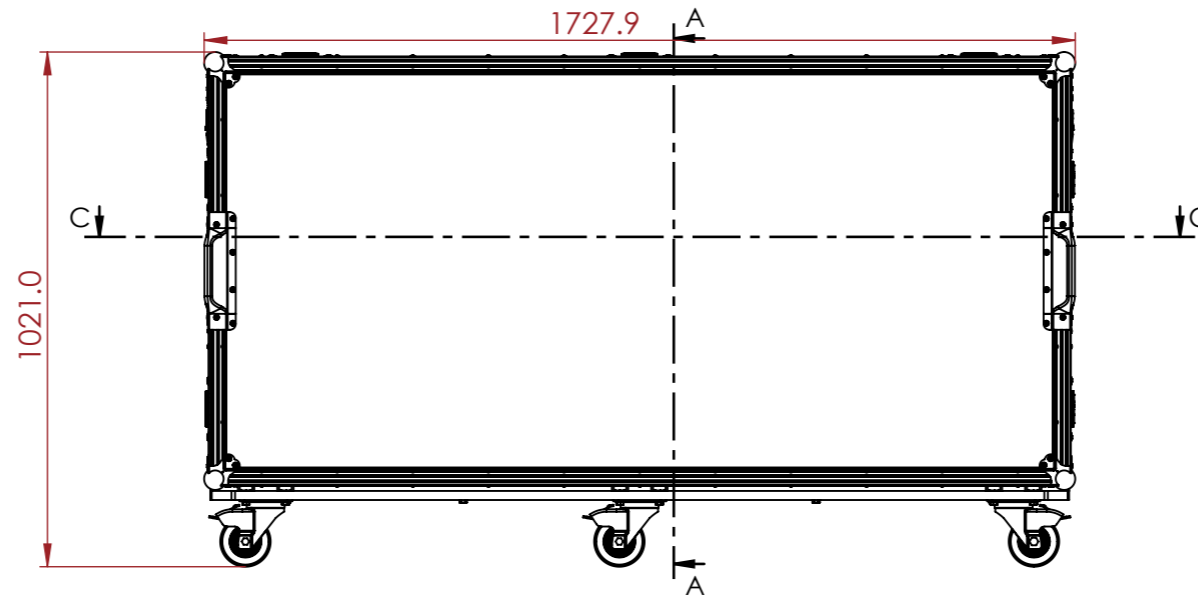
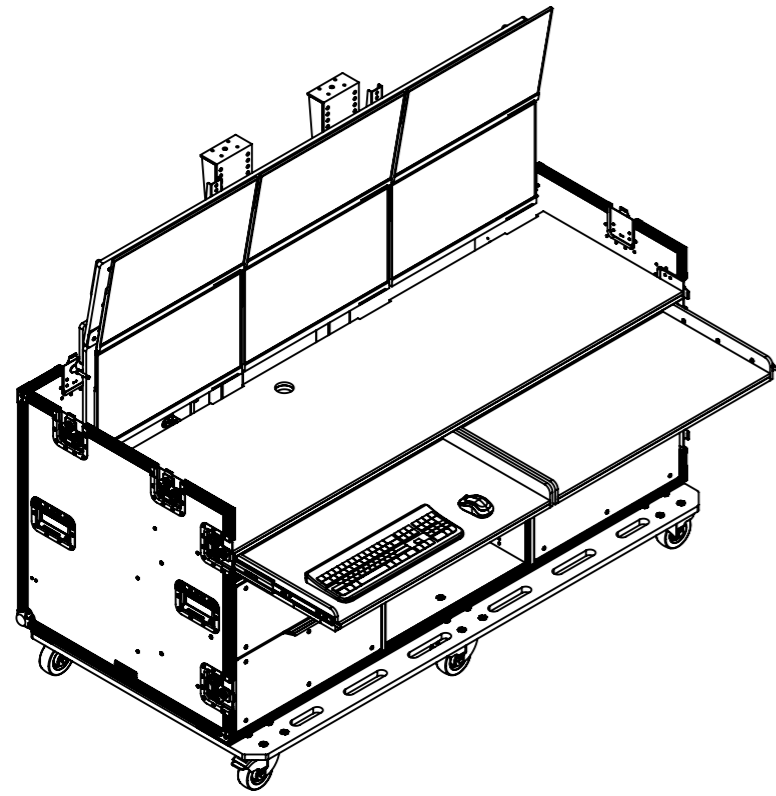

SECTION C-C

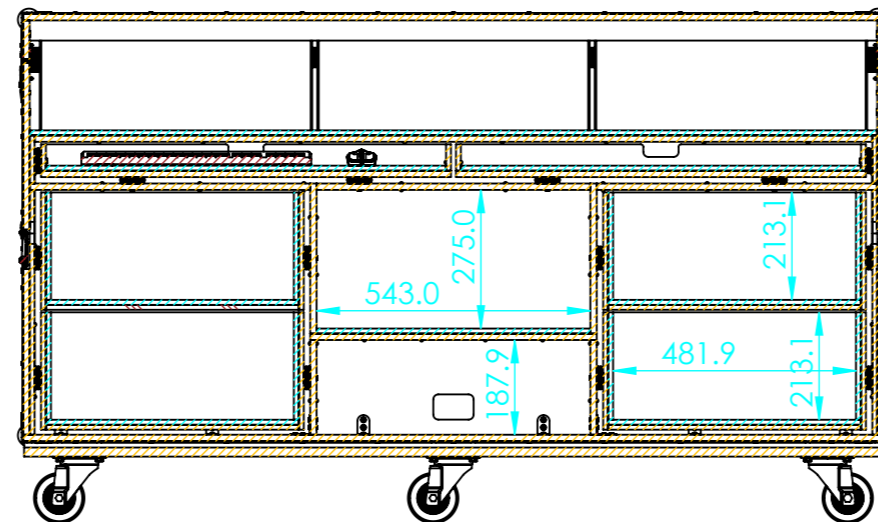
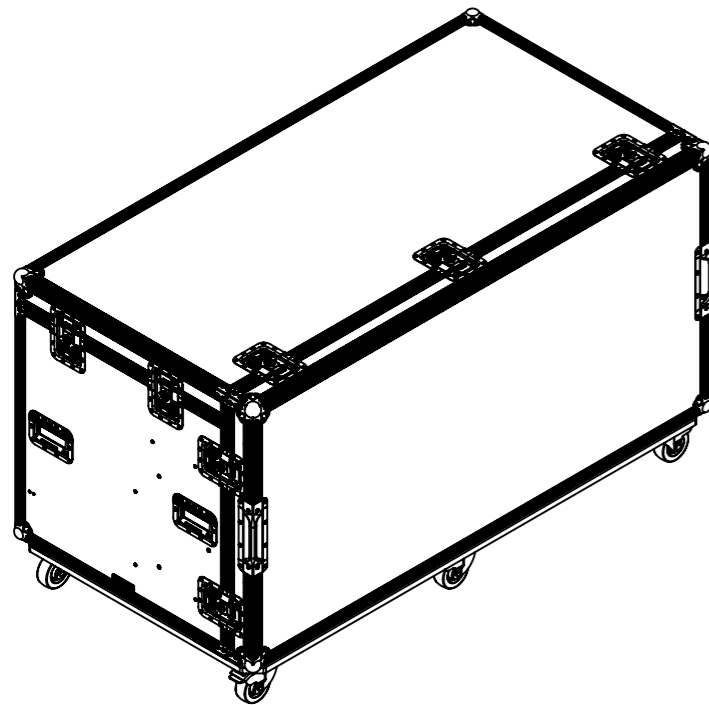

SECTION B-B

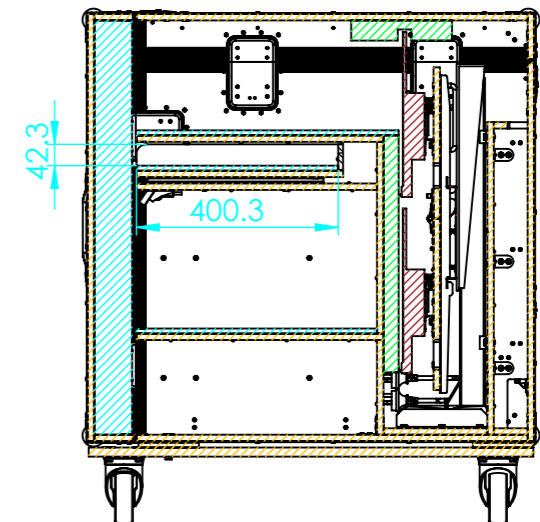

SECTION A-A