

PRODUCT FEATURES

CONSTRUCTION

- 12MM BIRCH VENEER PLYWOOD WITH HPL EXTERIOR FACE AND PVC INTERIOR FACE
- PENN ELCOM HARDWARE
- 6X ERGONOMICALLY PLACED HANDLES FOR LIFTING AND TRANSPORTING
- 4X MEDIUM LATCHES
- EVA FOAM PROTECTION

INSTALLED EQUIPMENT (NOT INCLUDED)

- 1X BEHRINGER X32 PRODUCER

FEATURES

- COMPACT DESIGN
- LIFT OFF LID
- STORAGE SPACE UNDERNEATH THE CONSOLE

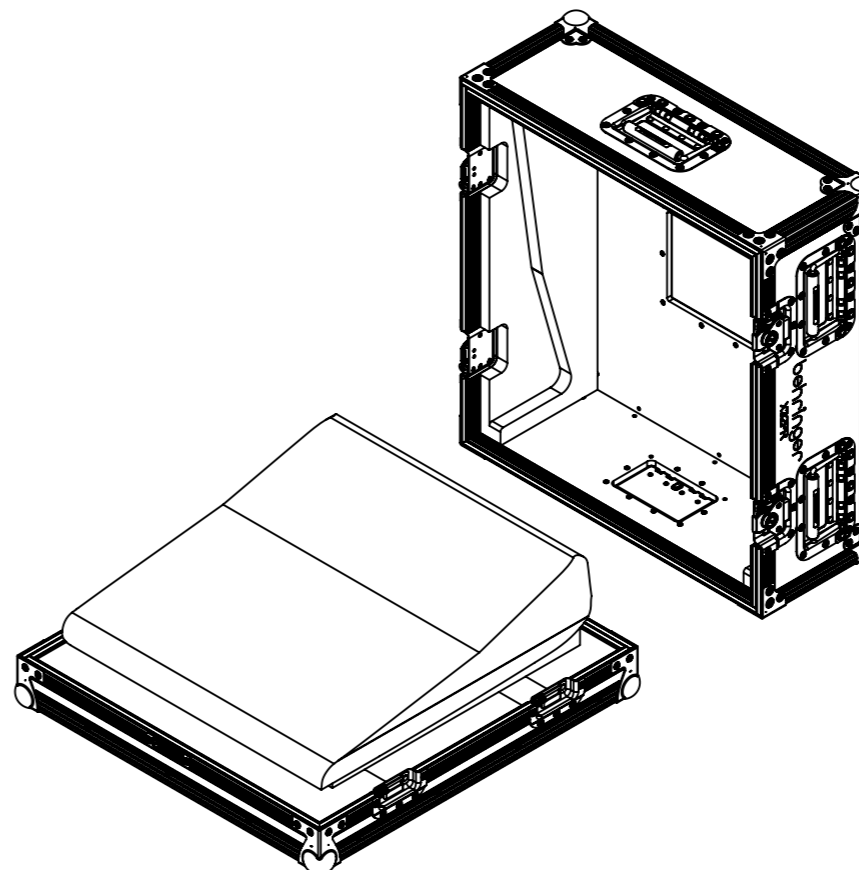
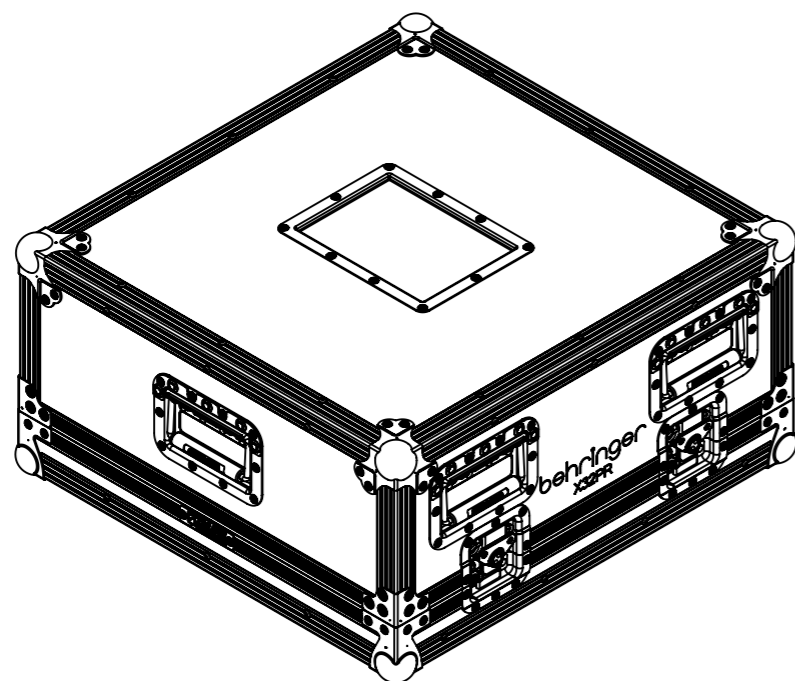
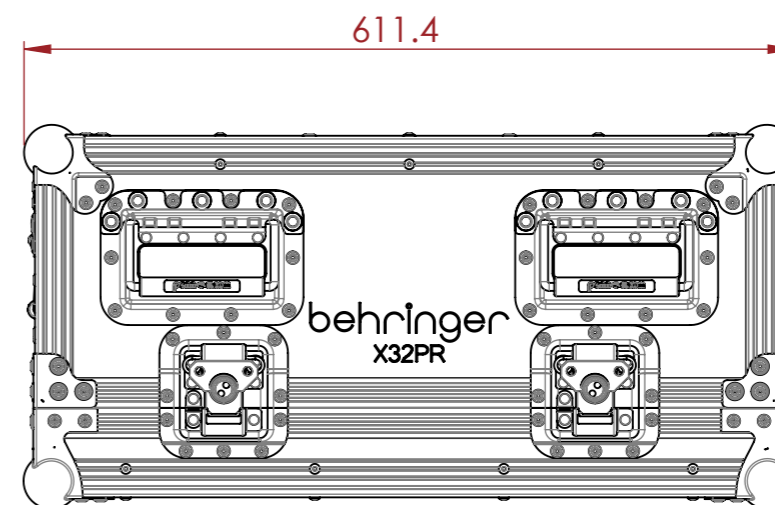
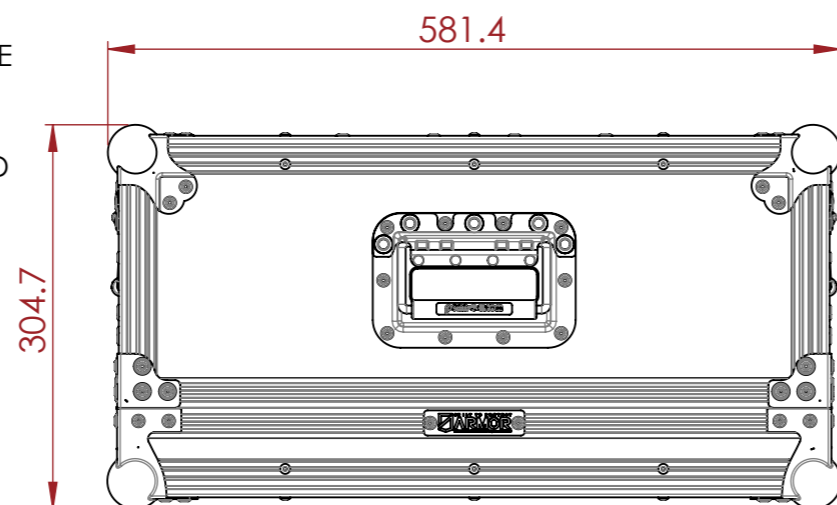

NOTES:

UNLESS SPECIFIED IN THE DRAWING, ALL PRODUCTS DISPLAYED IN THIS DRAWING OTHER THAN THE CASE ITSELF IS NOT PART OF OUR PRODUCT OFFERING.

ESTIMATED WEIGHT (CASE ONLY):

17.64 KG

ITEM CODE:

MIXR-BEH-X32PR

DRAWN BY:

RP

CHECKED BY:

AS

SCALE:

NTS



MAIL : sales@armorcases.com.au
WEB : www.armorcases.com.au