

PRODUCT FEATURES

CONSTRUCTION

- 12MM BIRCH VENEER PLYWOOD WITH HPL EXTERIOR FACE AND PVC INTERIOR FACE
- PENN ELCOM HARDWARE

INSTALLED EQUIPMENT (INCLUDED)

- 4X VESA MOUNTS(100X100/75X75)
- 2X POWERBOARD

INSTALLED EQUIPMENT (NOT INCLUDED)

- 2X LG 32" ULTRAGEAR QHD MONITOR(32GP750-B)
- 2X TCL 32S615-AU 32" MONITOR
- 1X MONSTER 2.1.2 CHANNEL DOLBY ATMOS SOUNDBAR(MT-SB512DA)
- 1X MONSTER 2.1.2 CHANNEL DOLBY ATMOS SUBWOOFER(MT-SB512DA)
- 1X BROTHER HL-L2350DW LASER PRINTER
- 1X LENOVO THINKPAD UNIVERSAL THUNDERBOLT 4 DOCK(40B00135AU)

FEATURES

- HATCH DOOR AT THE BACK
- PULL OUT PLATFORM THAT CAN BE LOCKED AT MINIMUM AND MAXIMUM POSITION
- CABLE COMPARTMENT BEHIND THE PULL OUT PLATFORM WITH REMOVABLE LID FOR EASY ACCESS
- TILTABLE MONITOR SUPPORT

KEY MEASUREMENTS

- PULL OUT PLATFORM HEIGHT AT 920MM
- SMALL DRAWER INTERNAL - 431.9X339.1X125.1MM(WXDXH)
- BIG DRAWER INTERNAL - 431.9X339.1X283.8MM(WXDXH)

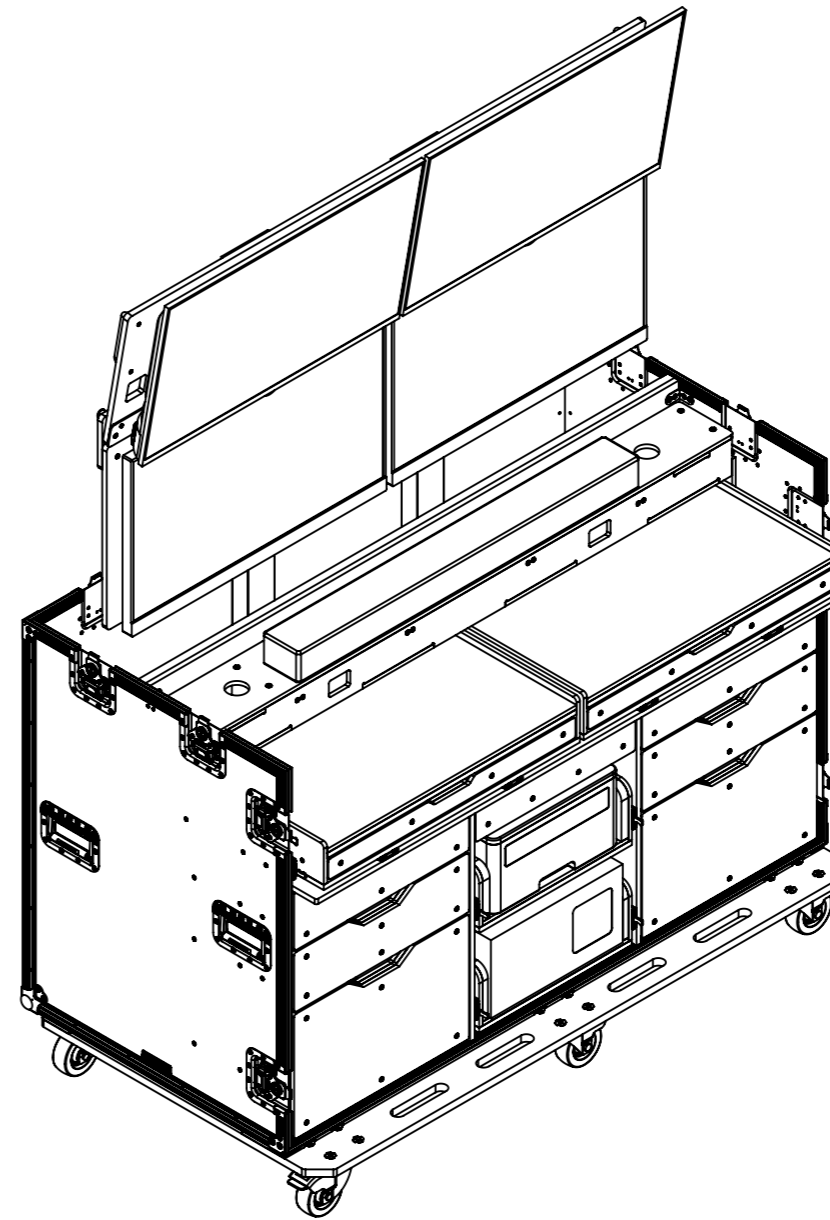
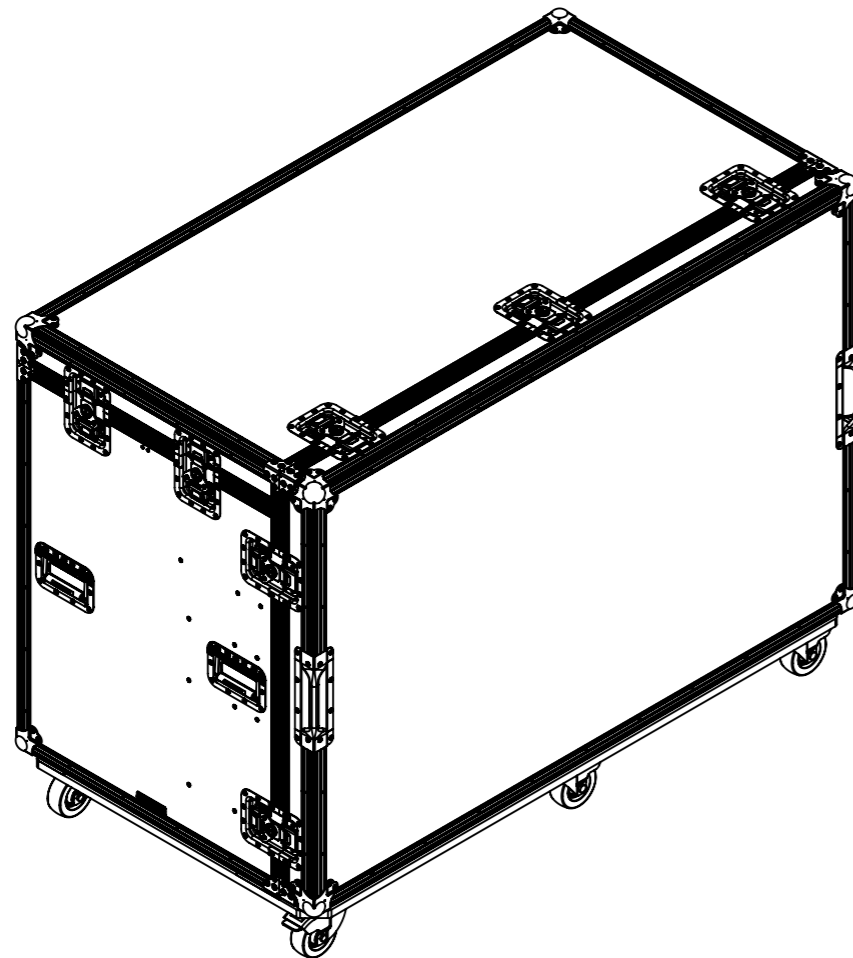
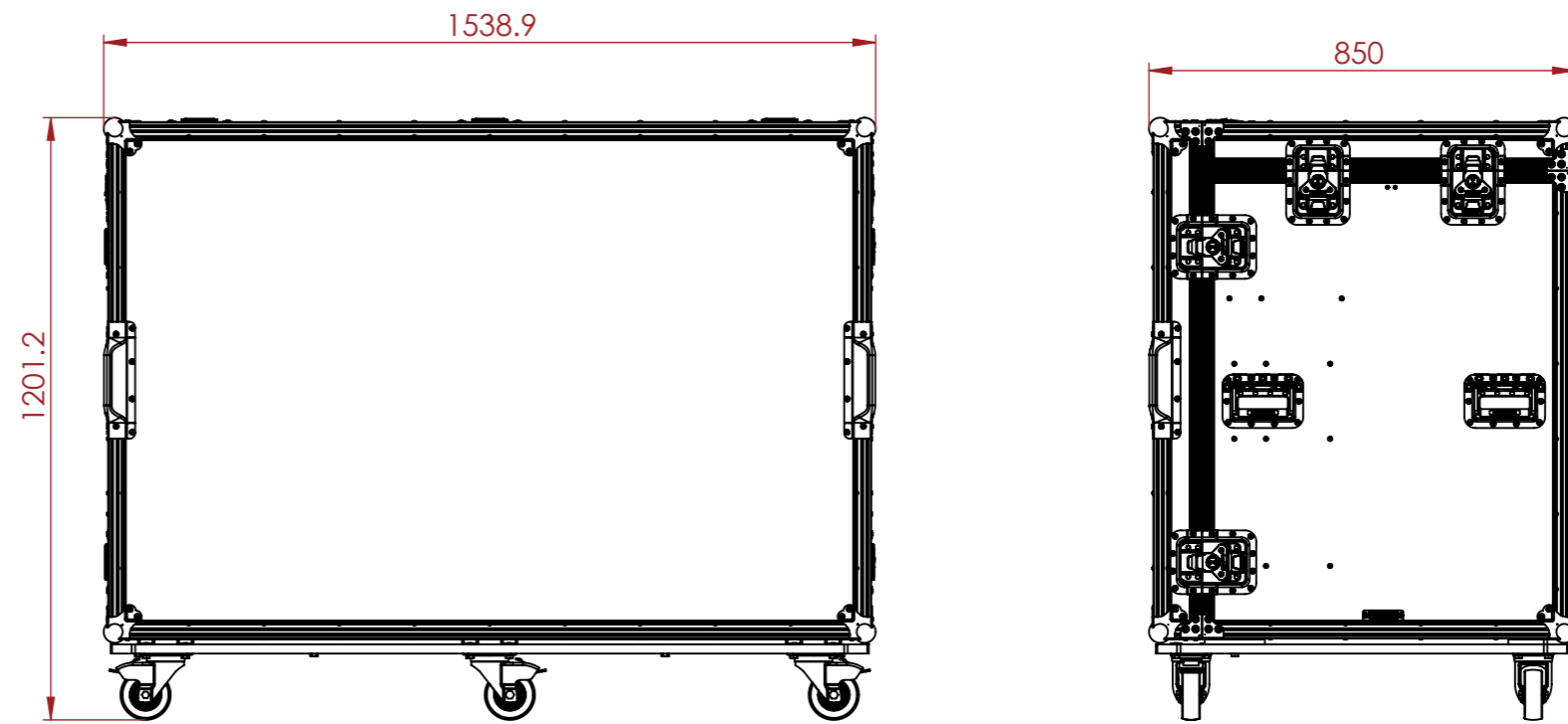

NOTES:

UNLESS SPECIFIED IN THE DRAWING, ALL PRODUCTS DISPLAYED IN THIS DRAWING OTHER THAN THE CASE ITSELF IS NOT PART OF OUR PRODUCT OFFERING.

ESTIMATED WEIGHT (CASE ONLY):

256.06 KG

ITEM CODE:

WS-FP3-SL4

DRAWN BY:

RP

CHECKED BY:

AS

SCALE:

NTS



MAIL : sales@armorcases.com.au
WEB : www.armorcases.com.au