

## PRODUCT FEATURES

### CONSTRUCTION

- 12MM BIRCH VENEER PLYWOOD WITH HPL EXTERIOR FACE AND PVC INTERIOR FACE
- PENN ELCOM HARDWARE

### INSTALLED EQUIPMENT (INCLUDED)

- FOUR MONITOR VESA ATTACHMENTS FOR 24 IN AND 22 INCH MONITORS, 100 X 100 VESA MOUNTS
- 2 STANDARD RACK BAYS

### FEATURES

- DETACHABLE LIDS AS WORKSTATION
- SLAM LID LOCATED ON THE BACK
- CUSTOM FOAM PROTECTION
- PULL OUT PERIPHERAL TRAY
- GAS STRUTS SUPPORTED TOP LID
- FLIP OUT SECOND MONITOR

### KEY MEASUREMENTS

- WORKBENCH HEIGHT AT 920MM
- FOLDABLE TABLE TOP HEIGHT 870MM

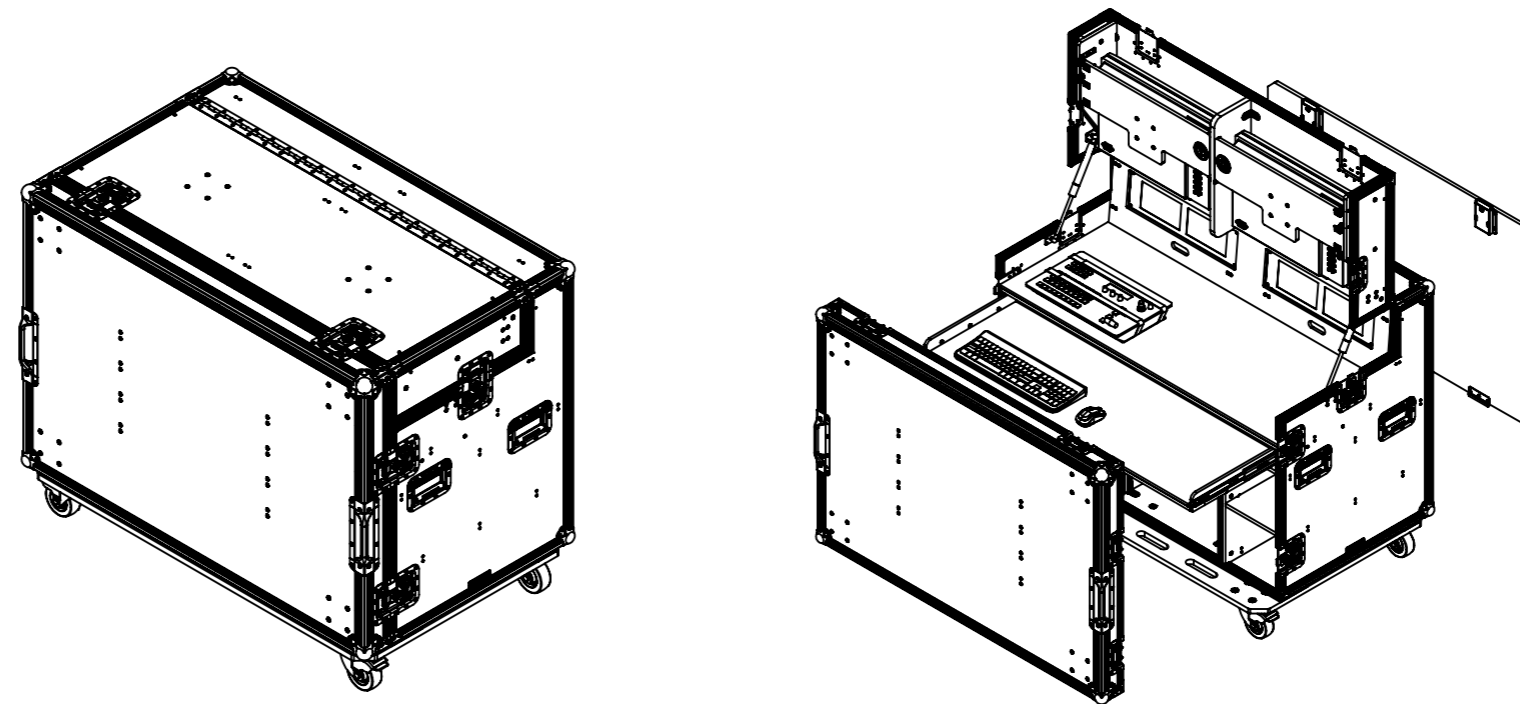
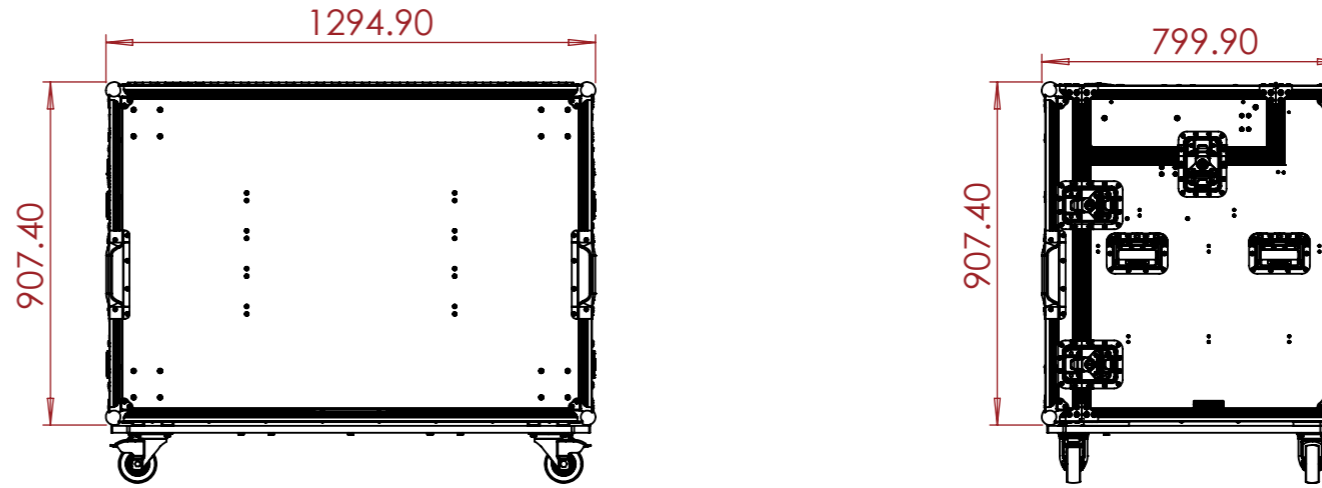

### NOTES:

UNLESS SPECIFIED IN THE DRAWING, ALL PRODUCTS DISPLAYED IN THIS DRAWING OTHER THAN THE CASE ITSELF IS NOT PART OF OUR PRODUCT OFFERING.

ESTIMATED WEIGHT (CASE ONLY):

130.26KG KG

ITEM CODE:

WS-FP2-Q

DRAWN BY:

RP

CHECKED BY:

AS

SCALE:

NTS



MAIL : [sales@armorcases.com.au](mailto:sales@armorcases.com.au)  
WEB : [www.armorcases.com.au](http://www.armorcases.com.au)