

PRODUCT FEATURES

CONSTRUCTION

- 9MM BIRCH VENEER PLYWOOD WITH HPL EXTERIOR FACE AND PVC INTERIOR FACE
- PENN ELCOM HARDWARE

INSTALLED EQUIPMENT (INCLUDED)

- 1X VESA MOUNT(100X100/75X75) FOR 24 INCH MONITOR
- 1X 1U PATCH PANEL WITH 8 HOLES FOR D-SERIES CONNECTORS
- 1X RACK PANEL WITH VENT
- 1X POWERCON IN
- 1X POWERCON THRU
- 4X DMX 5-PIN FEMALE D-SERIES CONNECTOR
- 1X USB 3.0 D-SERIES CONNECTOR
- 1X RJ45 D-SERIES CONNECTOR
- 1X POWERBOARD

INSTALLED EQUIPMENT (NOT INCLUDED)

- GRANDMA3 ON PC COMMAND WING XT
- DELL P2418HT 24" MONITOR
- KEYBOARD

FEATURES

- FOLDABLE MONITOR STAND THE CAN BE SETUP AT THREE DIFFERENT ANGLES
- LED LIGHTING FOR THE CONSOLE
- KEYBOARD DRAWER

KEY MEASUREMENTS

- MAXIMUM DIMENSIONS OF MONITORS THAT CAN FIT IN : 540X340X48MM(WXHXD)

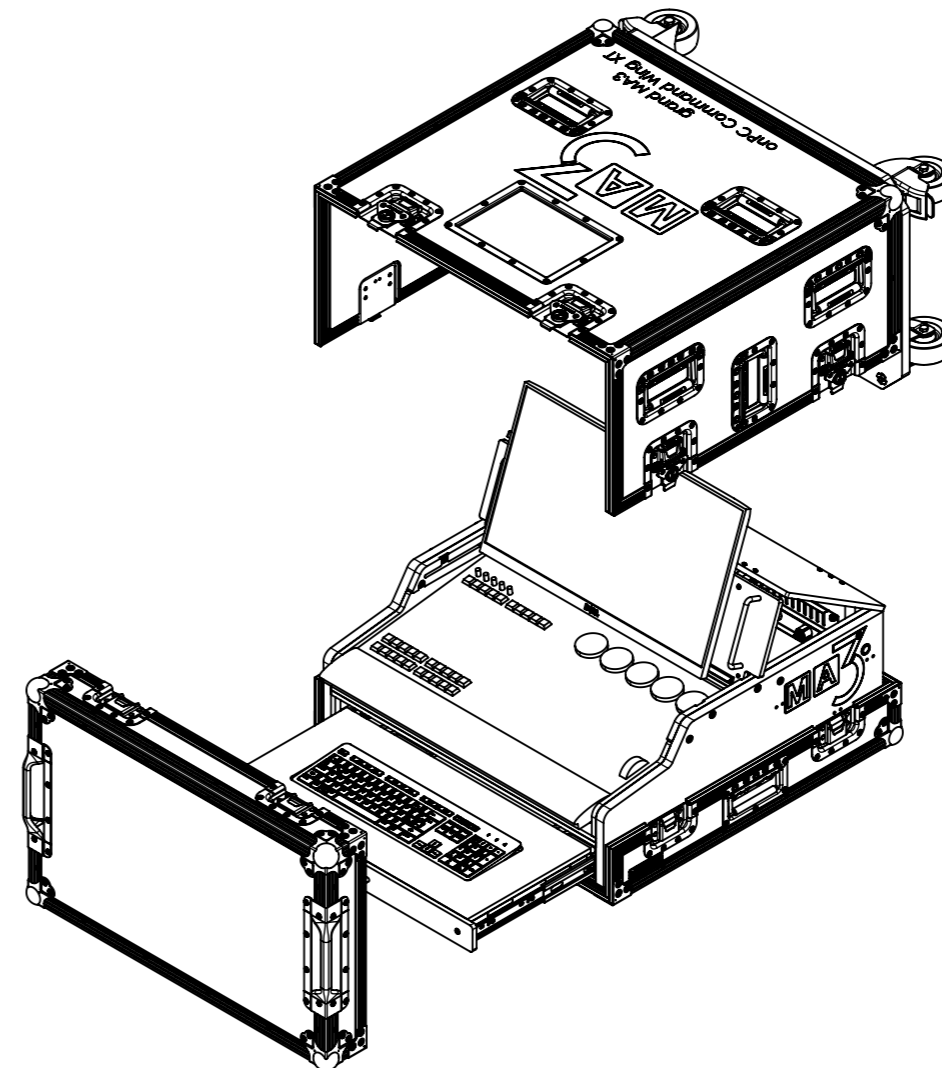
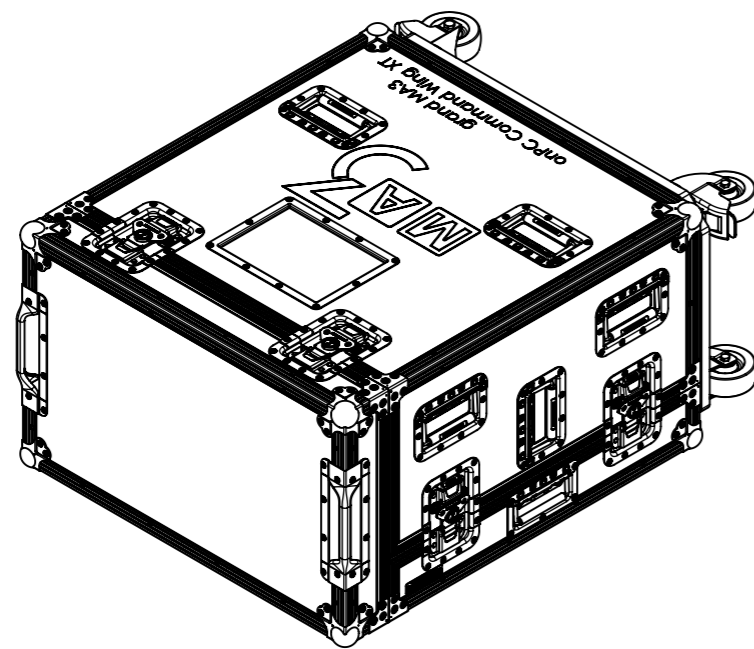
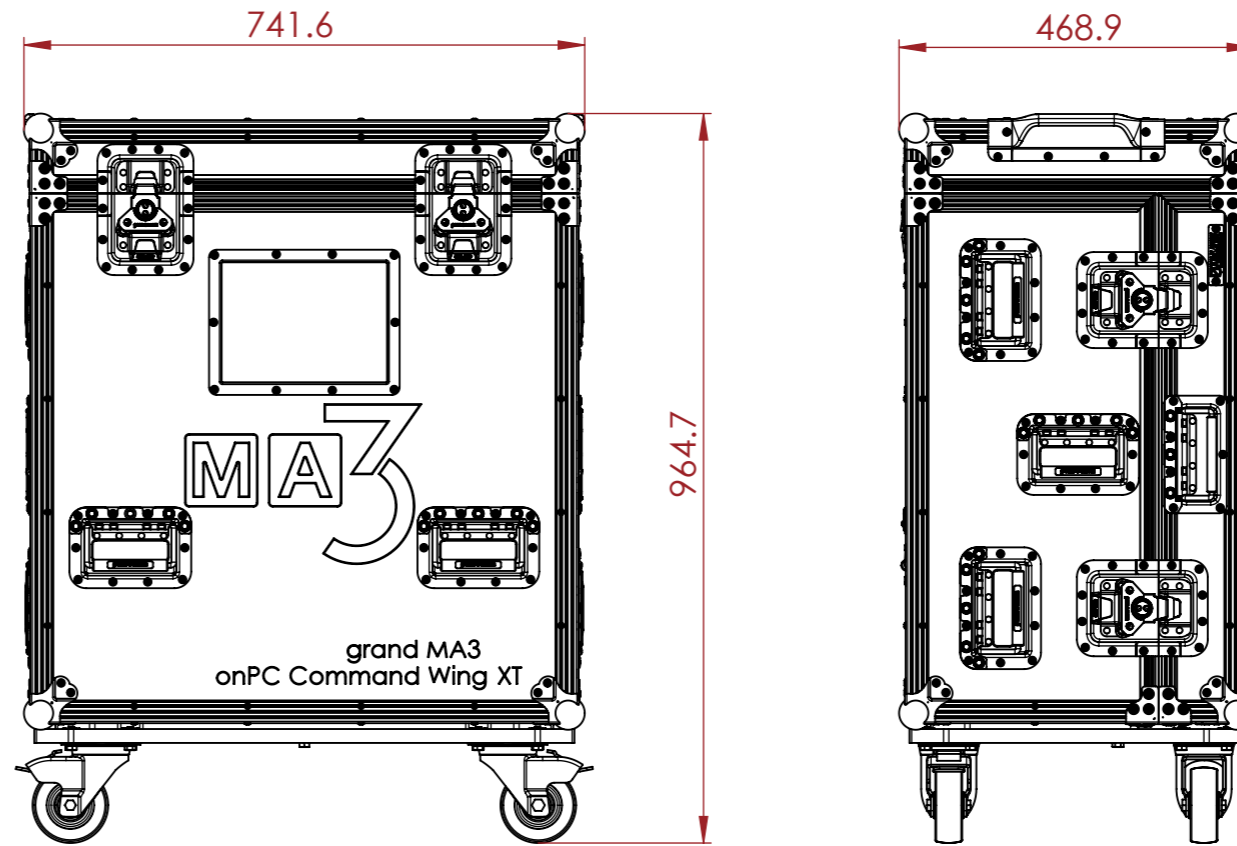

NOTES:

UNLESS SPECIFIED IN THE DRAWING, ALL PRODUCTS DISPLAYED IN THIS DRAWING OTHER THAN THE CASE ITSELF IS NOT PART OF OUR PRODUCT OFFERING.

ESTIMATED WEIGHT (CASE ONLY):

58.8 KG

ITEM CODE:

LXCTRL-MA3CW-XT-M1

DRAWN BY:

RP

CHECKED BY:

AS

SCALE:

NTS



MAIL : sales@armorcases.com.au
WEB : www.armorcases.com.au