

## PRODUCT FEATURES

### CONSTRUCTION

- 12MM BIRCH VENEER PLYWOOD WITH HPL EXTERIOR FACE AND PVC INTERIOR FACE
- PENN ELCOM HARDWARE
- 18MM BIRCH PLYWOOD INSERT

### INSTALLED EQUIPMENT (INCLUDED)

- ONE MONITOR VESA ATTACHMENTS FOR 24 IN MONITOR, 100 X 100 VESA MOUNTS
- PULLOUT DRAWER FOR KEYBOARD

### FEATURES

- GAS STRUT SUPPORTED CONSOLE DECK
- DETACHABLE CONSOLE DECK
- DOOR POCKETS

### KEY MEASUREMENTS

- WORKBENCH HEIGHT AT 920MM
- FOLDABLE TABLE TOP HEIGHT 870MM

### DESIGN SPECIFICATIONS

- EXTRA POCKETS TO STORE ACCESSORIES
- UNIT NEEDS TO HAVE REAR DOOR ACCESS
- GAS STRUTS TO BE USED INSTEAD OF RATCHET LID STAYS

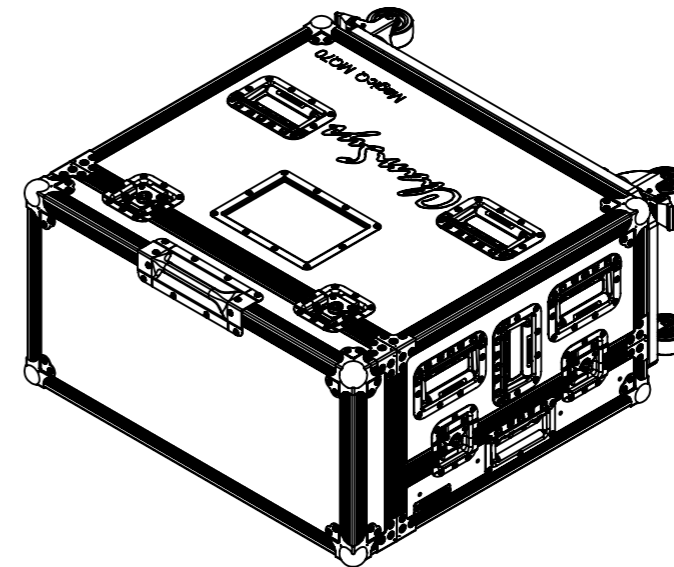
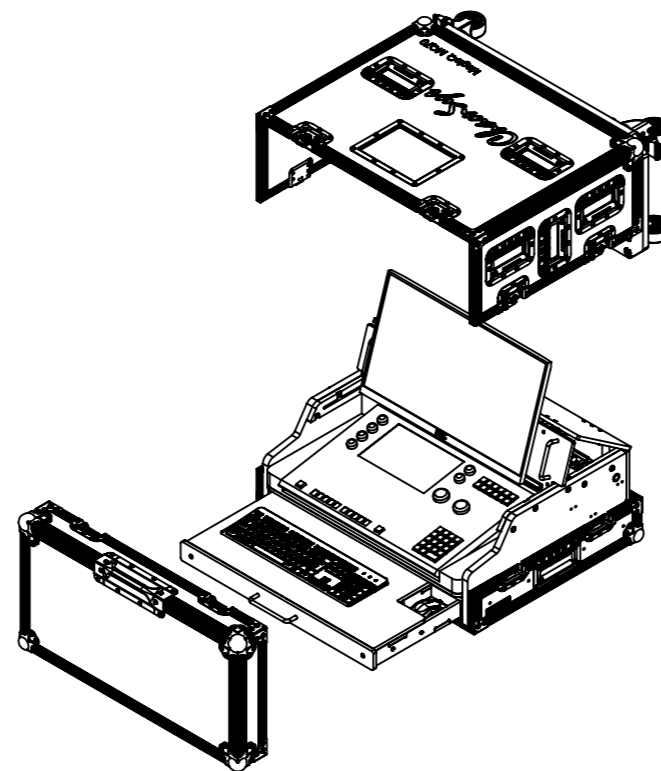
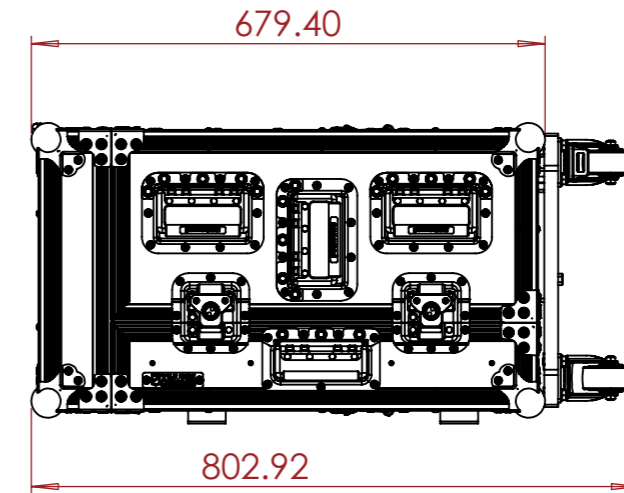
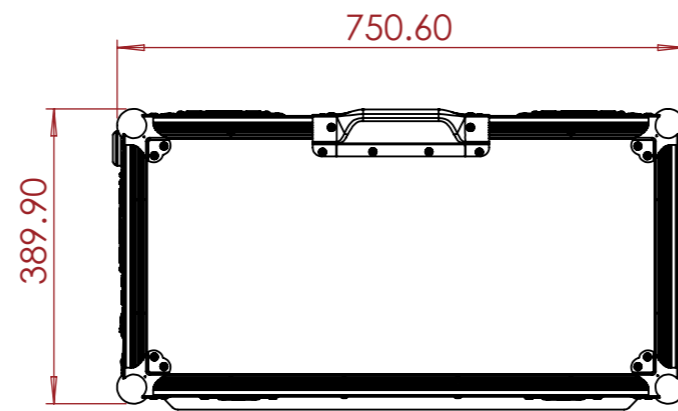

#### NOTES:

UNLESS SPECIFIED IN THE DRAWING, ALL PRODUCTS DISPLAYED IN THIS DRAWING OTHER THAN THE CASE ITSELF IS NOT PART OF OUR PRODUCT OFFERING.

ESTIMATED WEIGHT (CASE ONLY):

43.42 KG

ITEM CODE:

LXCTRL-CMS-MQ70-P24

DRAWN BY:

RP

CHECKED BY:

AS

SCALE:

NTS



MAIL : [sales@armorcases.com.au](mailto:sales@armorcases.com.au)  
WEB : [www.armorcases.com.au](http://www.armorcases.com.au)