

PRODUCT FEATURES

CONSTRUCTION

- 7mm LIGHT WEIGHT POLYPROPYLENE FLIGHT PANEL
- ARMOR HARDWARE

INSTALLED EQUIPMENT (INCLUDED)

- 4X CASTORS 2X BRAKED
- FLAT CORNERS
- 4X MEDIUM LATCHES
- 1X LARGE RECESSED HANDLE

FEATURES

- LIFT-OFF LID DESIGN

KEY MEASUREMENTS

- NONE

DESIGN SPECIFICATIONS

- REMOVEABLE CASTORBOARD

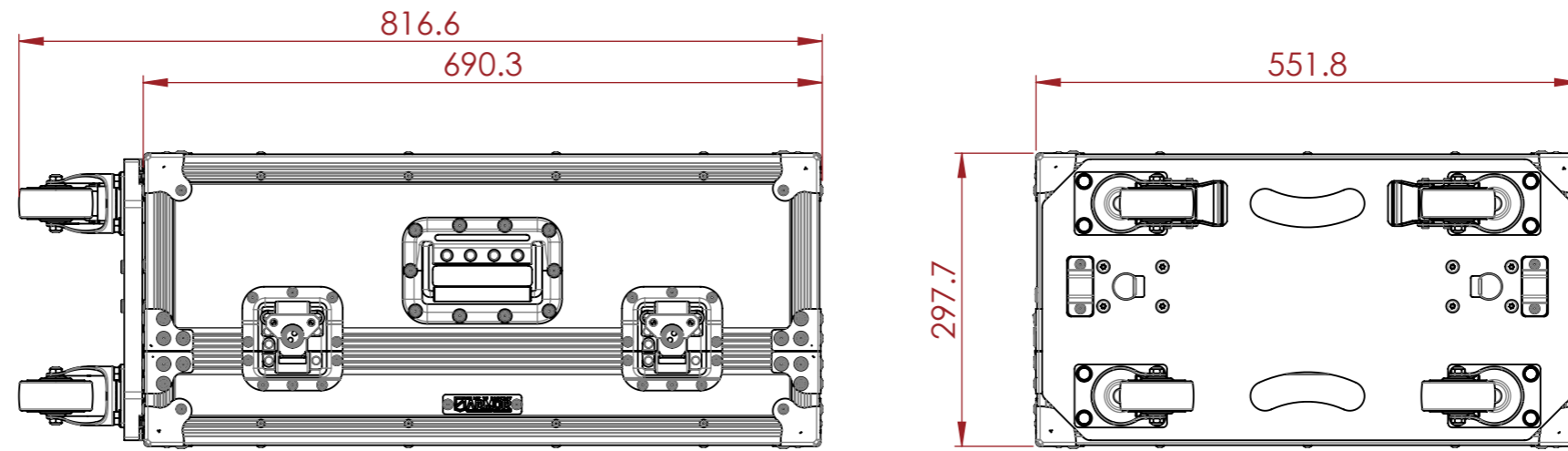

NOTES:

UNLESS SPECIFIED IN THE DRAWING, ALL PRODUCTS DISPLAYED IN THIS DRAWING OTHER THAN THE CASE ITSELF IS NOT PART OF OUR PRODUCT OFFERING.

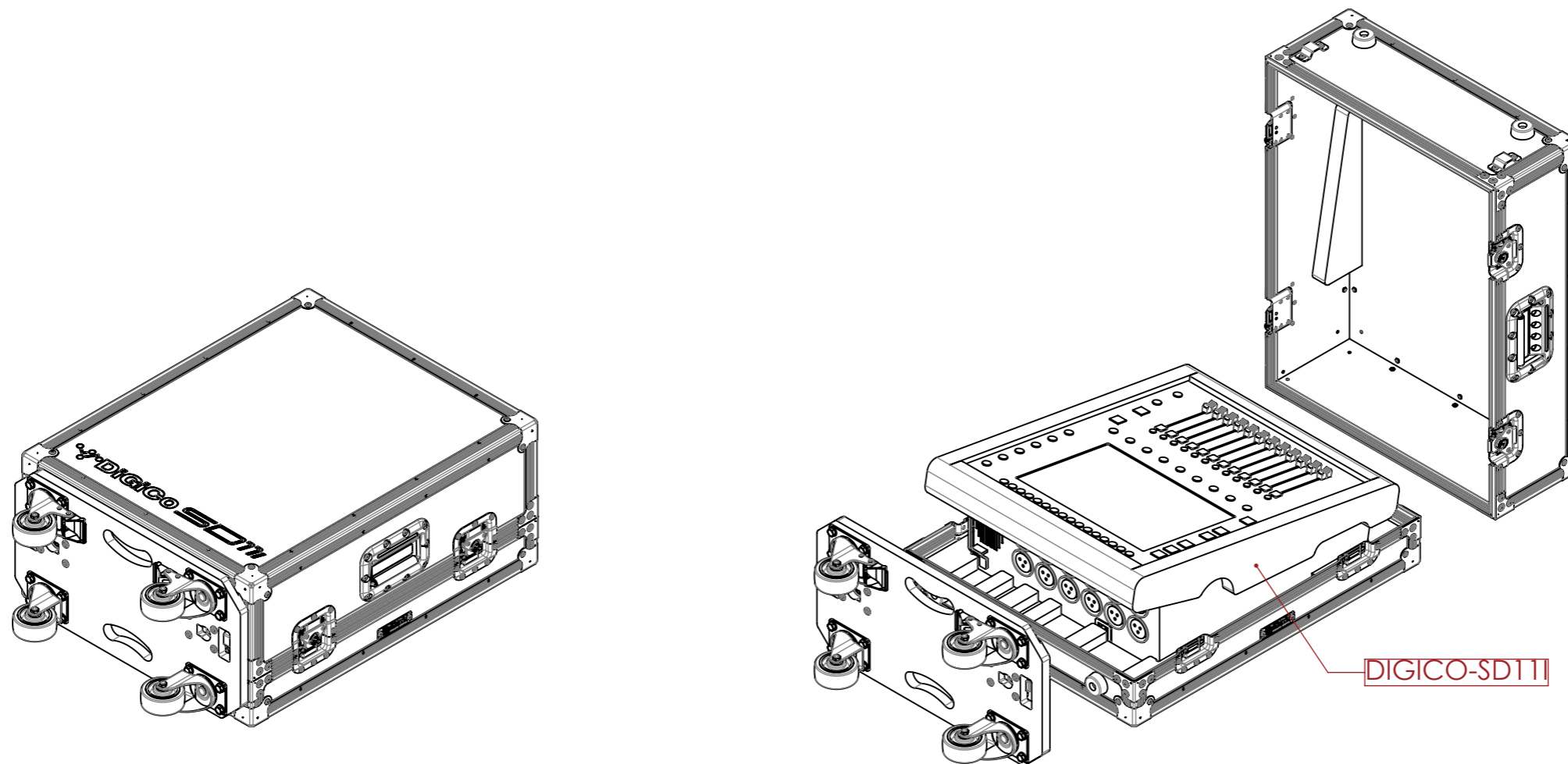

Weight of case without castor board ~ 8kg

ESTIMATED WEIGHT (CASE ONLY):

12.8 KG

ITEM CODE:

MIXR-DIGI-SD11I-F

DRAWN BY:

HA

CHECKED BY:

AS

SCALE:

NTS



MAIL : sales@armorcases.com.au
WEB : www.armorcases.com.au