

PRODUCT FEATURES

CONSTRUCTION

- 12MM BIRCH VENEER PLYWOOD WITH HPL EXTERIOR FACE AND PVC INTERIOR FACE
- PENN ELCOM HARDWARE

INSTALLED EQUIPMENT (INCLUDED)

- CREA SPECTROIL M

FEATURES

- FRONT LID CAN BE SETUP ON THE RIGHT OR LEFT SIDE OF THE WORKSTATION
- SLAM LID LOCATED ON THE BACK

KEY MEASUREMENTS

- WORKBENCH HEIGHT AT 920MM
- FOLDABLE TABLE TOP HEIGHT 870MM

DESIGN SPECIFICATIONS

- EXTRA POCKETS TO STORE ACCESSORIES
- UNIT NEEDS TO HAVE REAR DOOR ACCESS
- GAS STRUTS TO BE USED INSTEAD OF RATCHET LID STAYS

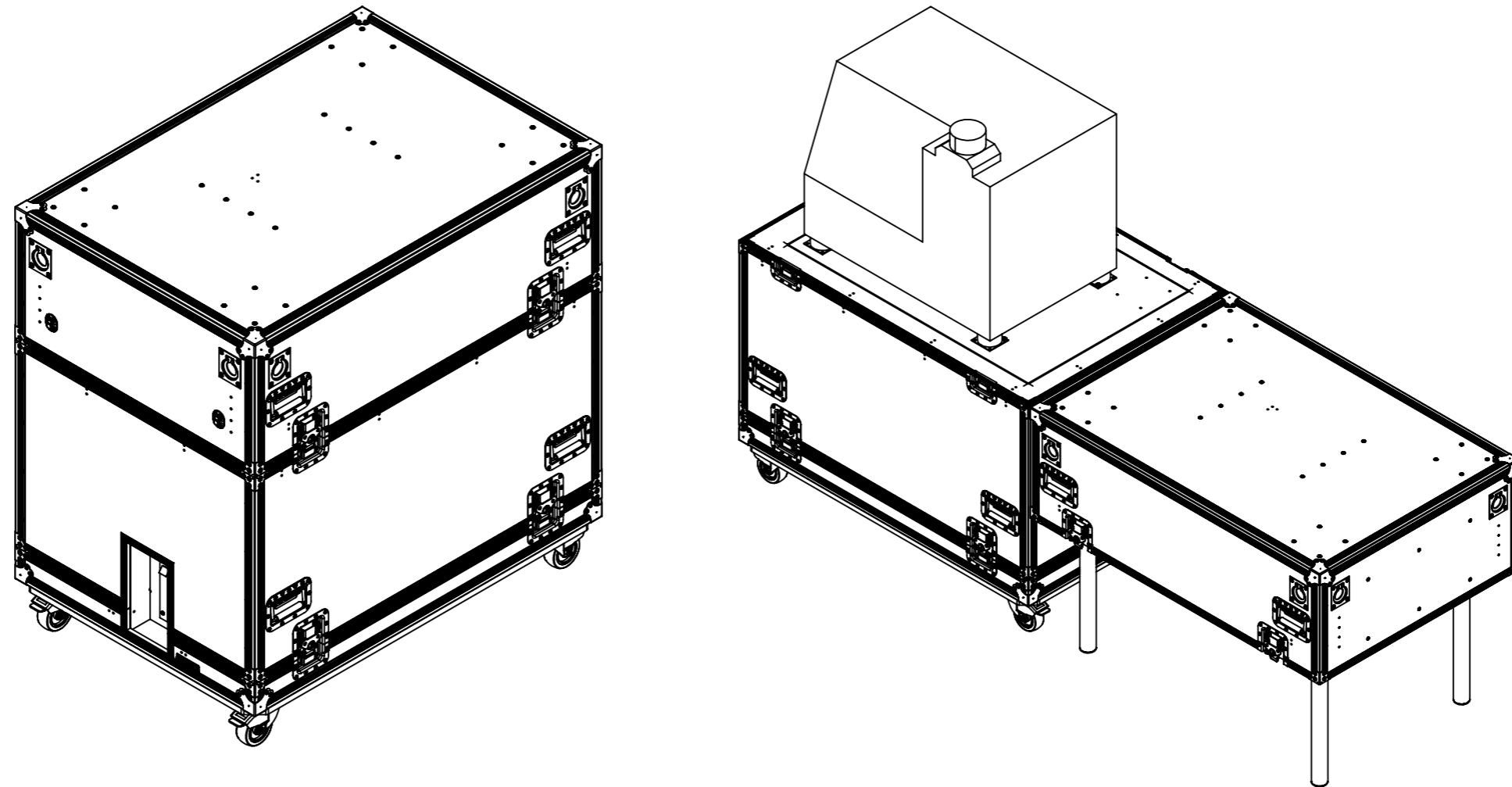
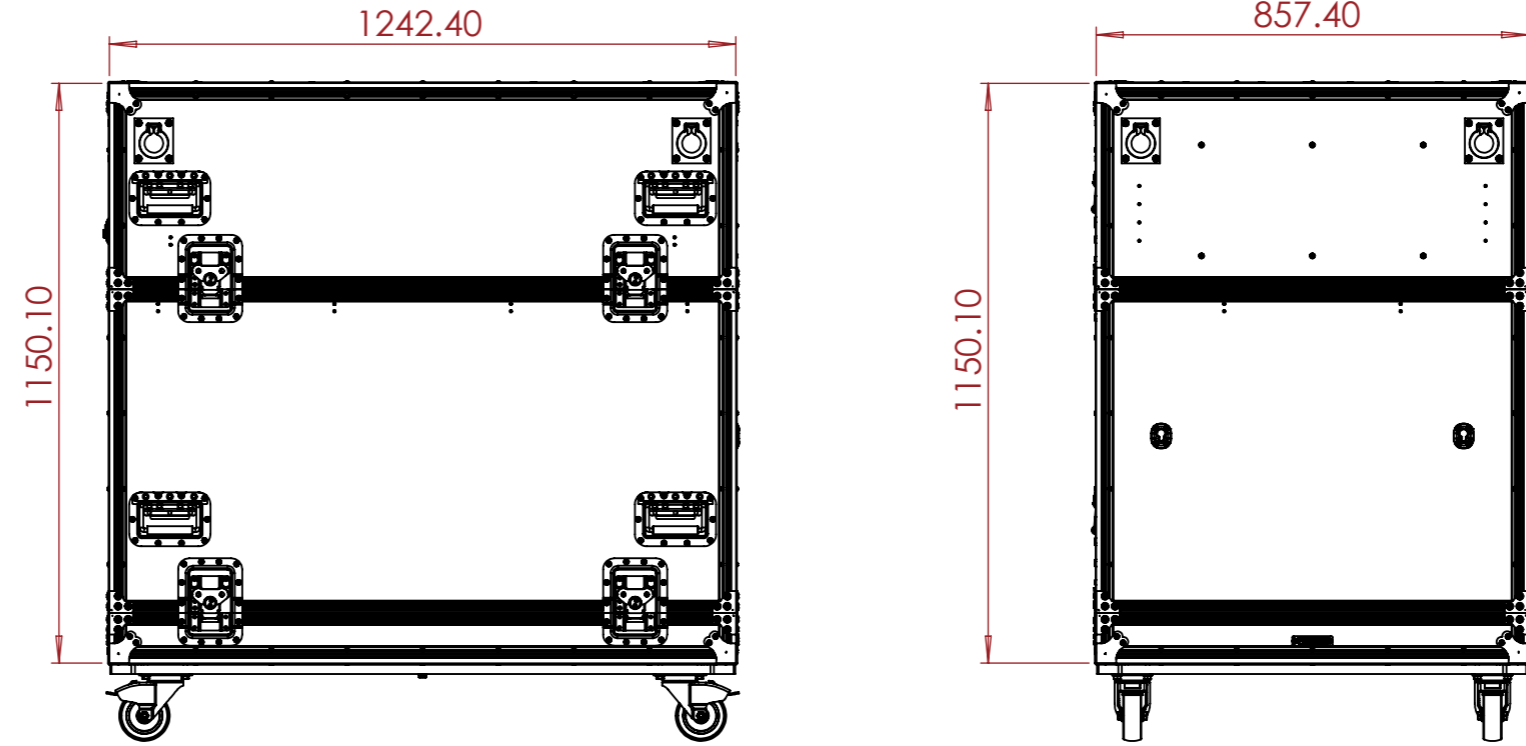

NOTES:
UNLESS SPECIFIED IN THE DRAWING,
ALL PRODUCTS DISPLAYED IN THIS
DRAWING OTHER THAN THE CASE
ITSELF IS NOT PART OF OUR PRODUCT
OFFERING.

ESTIMATED WEIGHT (CASE ONLY):

125.24 KG

ITEM CODE:

LIFT-CREA-SPECTROIL

DRAWN BY:

RP

CHECKED BY:

AS

SCALE:

NTS



MAIL : sales@armorcases.com.au
WEB : www.armorcases.com.au