

PRODUCT FEATURES

CONSTRUCTION

- 12MM BIRCH VENEER PLYWOOD WITH HPL EXTERIOR FACE AND PVC INTERIOR FACE
- PENN ELCOM HARDWARE
- 18MM BIRCH PLYWOOD INSERT

INSTALLED EQUIPMENT (INCLUDED)

- ONE MONITOR VESA ATTACHMENTS FOR 24 IN MONITOR, 100 X 100 VESA MOUNT
- FRONT TO BACK RACK STRIP DISTANCE AT 562MM
- 1X PULL OUT DRAWER

FEATURES

- DUAL POCKETS LOCATED ON THE LEFT SIDE WITH 100MM WIDTH
- PULL OUT KEYBOARD DRAWER WITH FLIP OUT MOUSE PAD
- GAS STRUTS SUPPORTED TOP LID
- GAS STRUTS SUPPORTED PANELS

KEY MEASUREMENTS

- WORKBENCH HEIGHT AT 920MM
- FOLDABLE TABLE TOP HEIGHT 870MM

DESIGN SPECIFICATIONS

- EXTRA POCKETS TO STORE ACCESSORIES
- UNIT NEEDS TO HAVE REAR DOOR ACCESS
- GAS STRUTS TO BE USED INSTEAD OF RATCHET LID STAYS

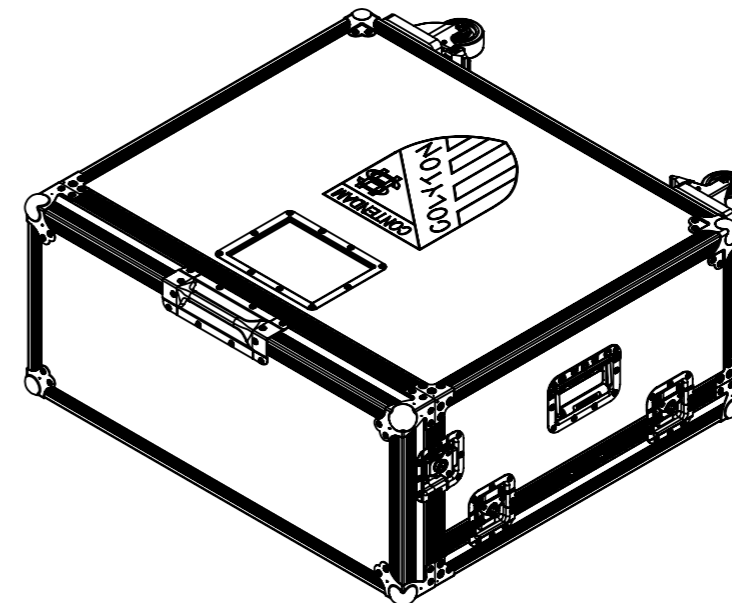
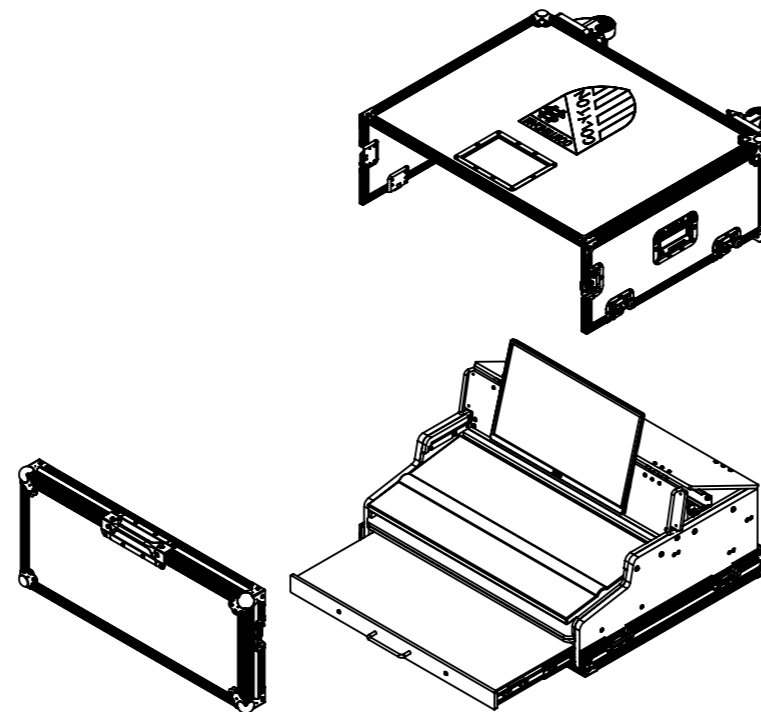
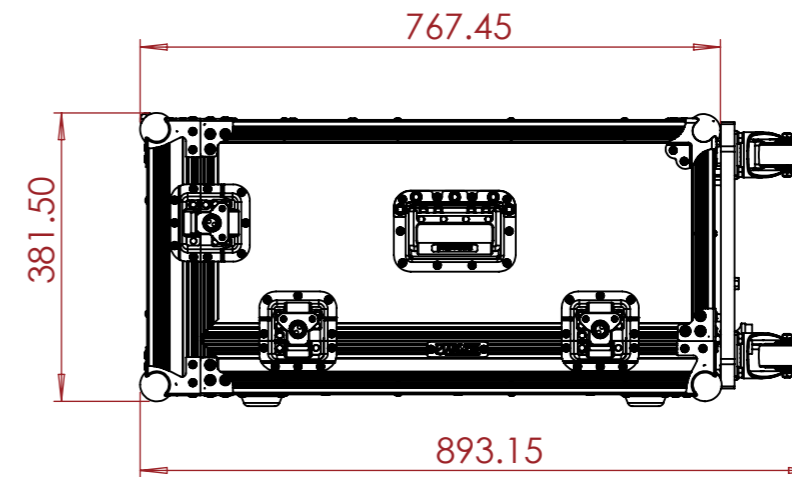
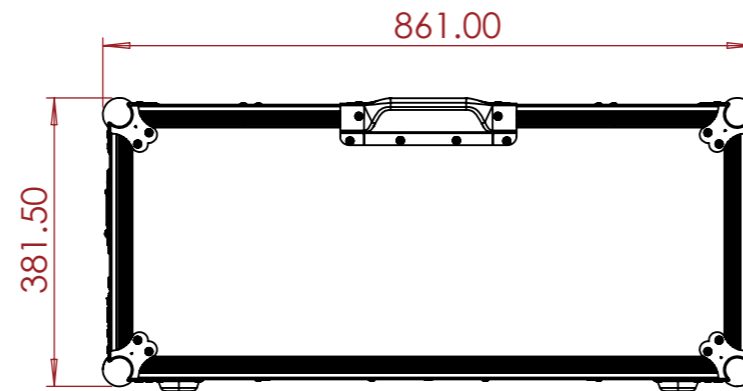

NOTES:

UNLESS SPECIFIED IN THE DRAWING, ALL PRODUCTS DISPLAYED IN THIS DRAWING OTHER THAN THE CASE ITSELF IS NOT PART OF OUR PRODUCT OFFERING.

ESTIMATED WEIGHT (CASE ONLY):

48.85 KG

ITEM CODE:

LXCTRL-ETC-IONXE20-FP01

DRAWN BY:

K.I

CHECKED BY:

AS

SCALE:

NTS



MAIL : sales@armorcases.com.au
WEB : www.armorcases.com.au