

PRODUCT FEATURES

CONSTRUCTION

- 12MM BIRCH VENEER PLYWOOD WITH HPL EXTERIOR FACE AND PVC INTERIOR FACE
- 8X ERGONOMICALLY PLACED HANDLES FOR LIFTING AND TRANSPORTING
- LARGE LATCHES
- 1X MEDIUM LABEL DISH
- EVA38B FOAM PROTECTION
- 18MM FULL CASTOR BOARD
- 4X 100MM CASTORS 2X BRAKED

FEATURES

- SPLIT LID CONSTRUCTION

KIO430L-SLIM [REFERENCE MODEL]

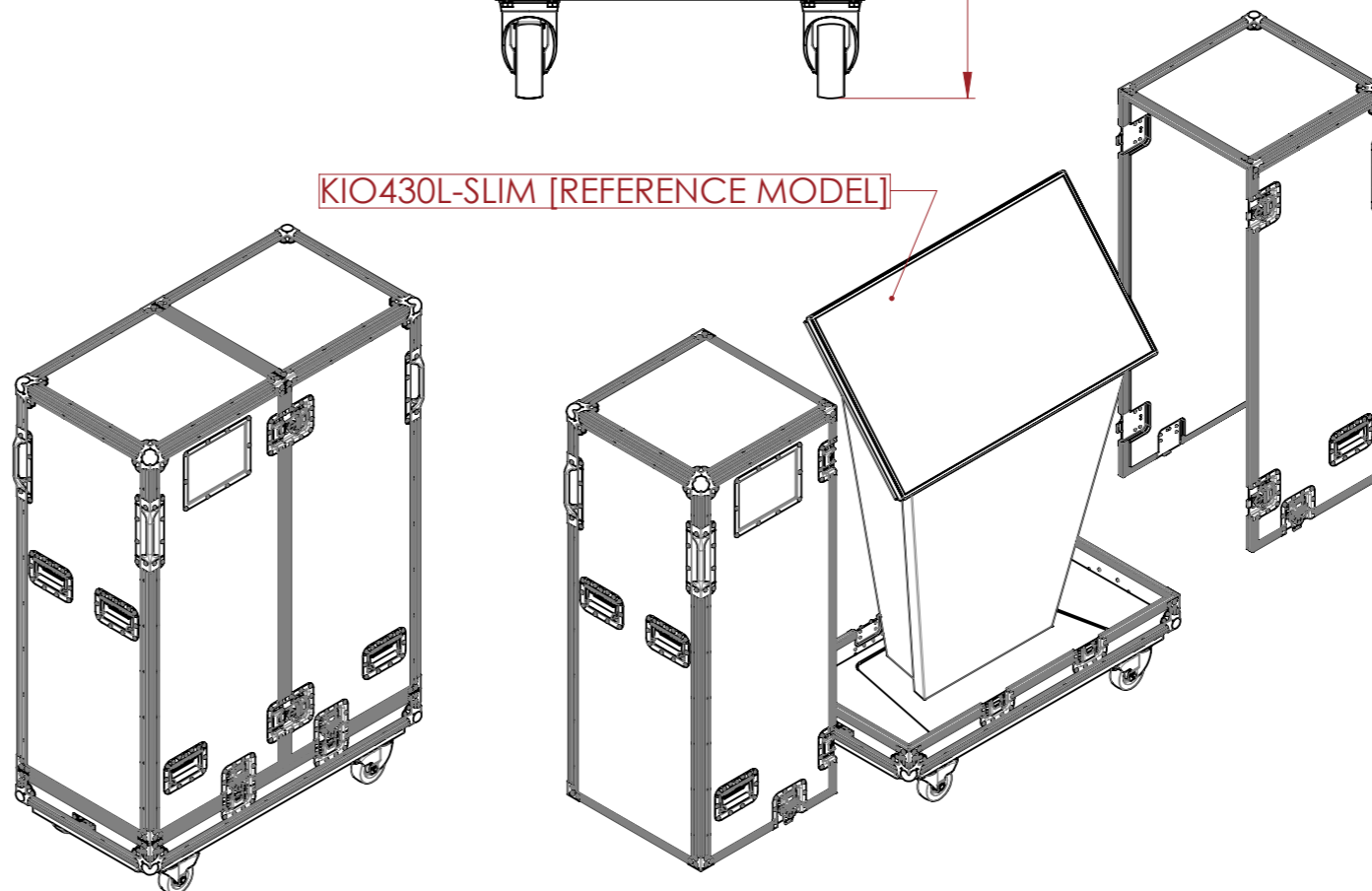

NOTES:

UNLESS SPECIFIED IN THE DRAWING, ALL PRODUCTS DISPLAYED IN THIS DRAWING OTHER THAN THE CASE ITSELF IS NOT PART OF OUR PRODUCT OFFERING.

ESTIMATED WEIGHT (CASE ONLY):

80.36 KG

ITEM CODE:

SPLIT-INT-KIO430L-SL

DRAWN BY:

K.I

CHECKED BY:

AS

SCALE:

NTS



MAIL : sales@armorcases.com.au
 WEB : www.armorcases.com.au