

PRODUCT FEATURES

CONSTRUCTION

- 9MM BIRCH VENEER PLYWOOD WITH HPL EXTERIOR FACE AND PVC INTERIOR FACE
- PENN ELCOM HARDWARE

FEATURES

- STORAGE SPACE FOR 2X YAMAHA DHR10 SPEAKERS
- 8X RECESSED HANDLES
- 4X LARGE LATCHES
- CASTOR DISHES FOR EASE OF STACKING
- 2X BRAKED CASTORS
- 2X NON-BRAKED CASTORS

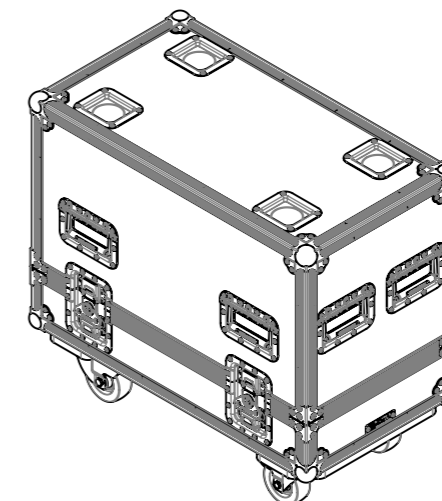
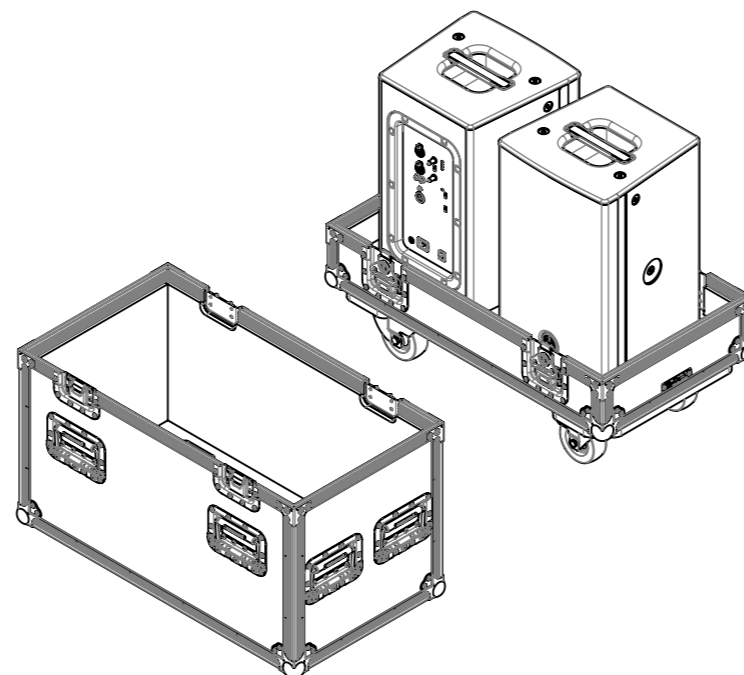
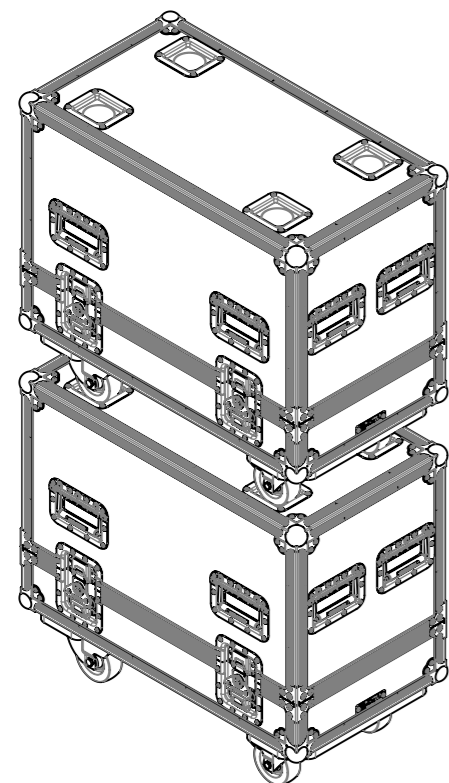
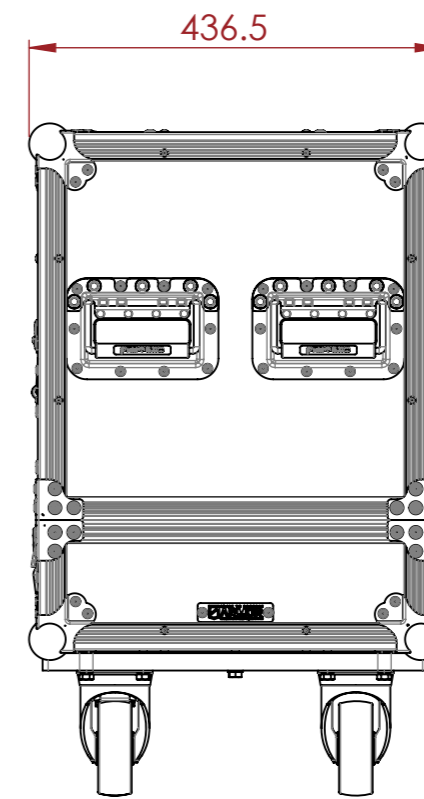
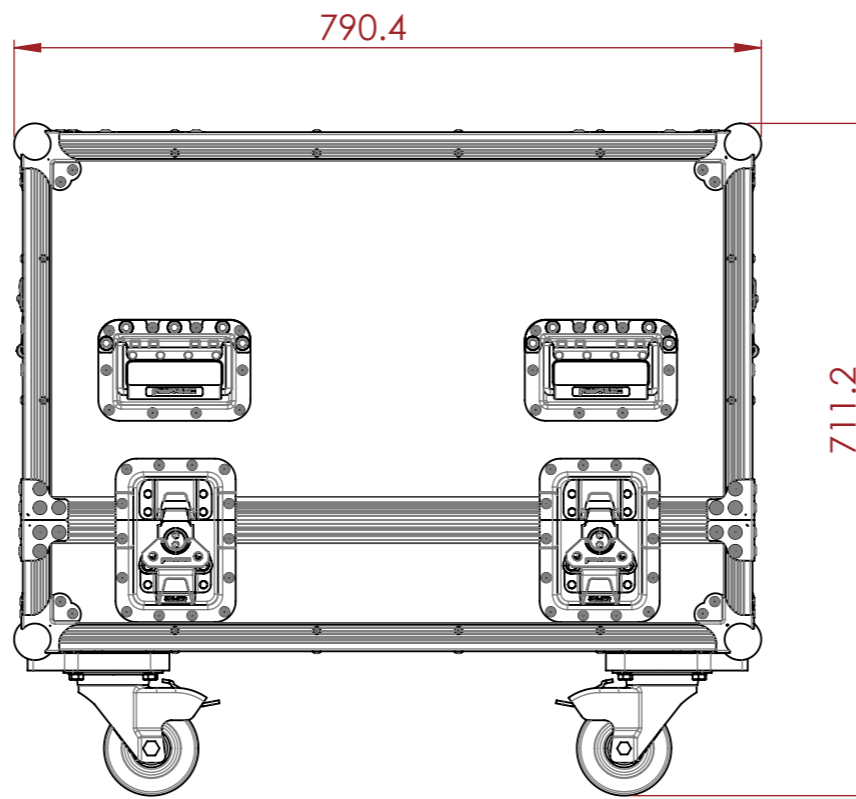

NOTES:
UNLESS SPECIFIED IN THE DRAWING,
ALL PRODUCTS DISPLAYED IN THIS
DRAWING OTHER THAN THE CASE
ITSELF IS NOT PART OF OUR PRODUCT
OFFERING.

ESTIMATED WEIGHT (CASE ONLY):

28.6 KG

ITEM CODE:

SPK-YMH-DHR10

DRAWN BY:

K.I

CHECKED BY:

AS

SCALE:

NTS



MAIL : sales@armorcases.com.au
WEB : www.armorcases.com.au