

PRODUCT FEATURES

CONSTRUCTION

- 9MM BIRCH VENEER PLYWOOD WITH HPL EXTERIOR FACE AND PVC INTERIOR FACE
- PENN ELCOM HARDWARE

INSTALLED EQUIPMENT (INCLUDED)

- 8X LARGE RECESSED HANDLES
- 4X LARGE LATCHES
- 4X 100mm CASTORS 2X BRAKED
- 4X STEEL CASTOR DISHES

FEATURES

- DEDICATED SPACE FOR 2X NEXO PS15-R2 SPEAKERS
- ENGRAVING ON FORNT AND BACK

KEY MEASUREMENTS

- NONE

DESIGN SPECIFICATIONS

- LIFT-OFF LID AND STACKABLE DESIGN

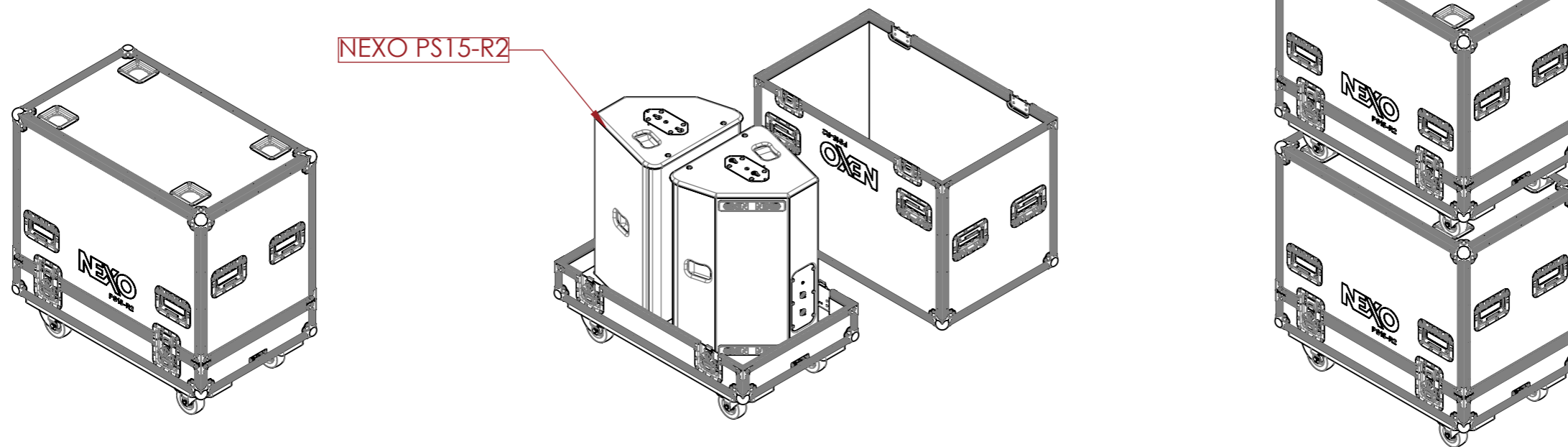
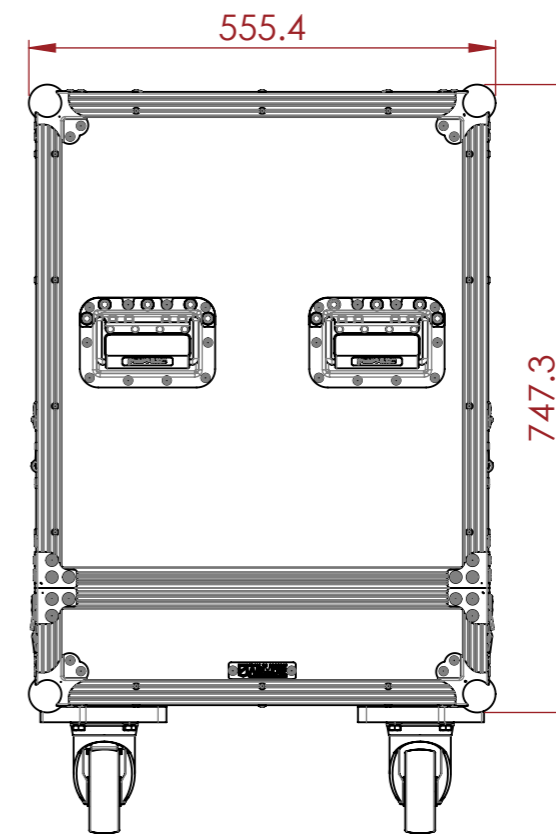
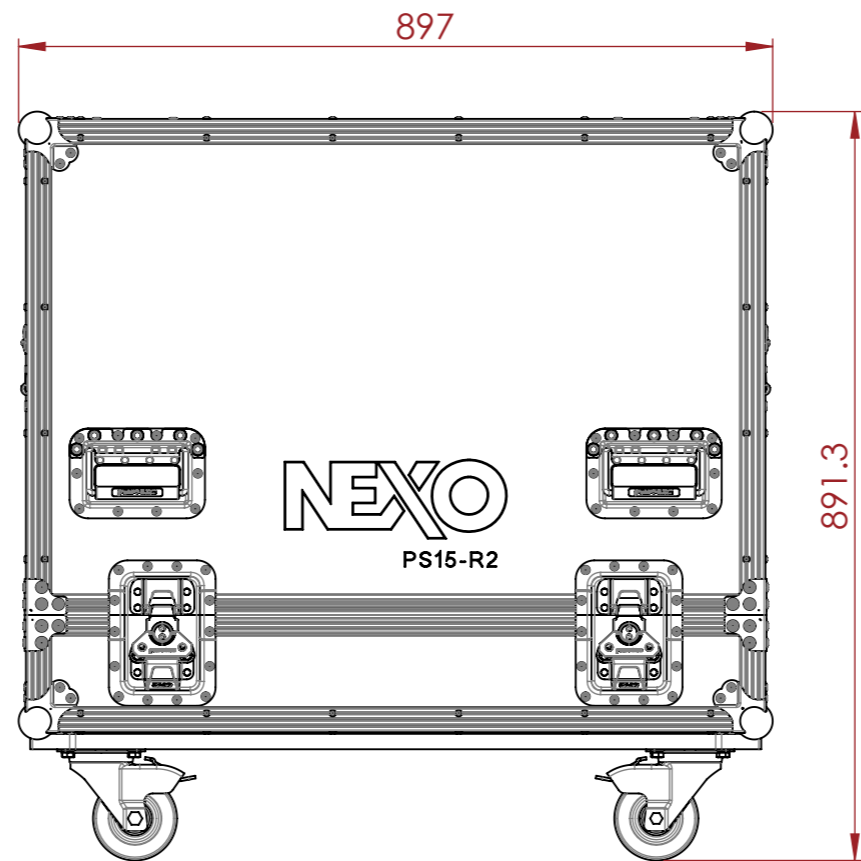

NOTES:

UNLESS SPECIFIED IN THE DRAWING, ALL PRODUCTS DISPLAYED IN THIS DRAWING OTHER THAN THE CASE ITSELF IS NOT PART OF OUR PRODUCT OFFERING.

ESTIMATED WEIGHT (CASE ONLY):

39.0 KG

ITEM CODE:

SPK-NEXO-PS15R2

DRAWN BY:

HA

CHECKED BY:

AS

SCALE:

NTS



MAIL : sales@armorcases.com.au
 WEB : www.armorcases.com.au