

SECTION A-A

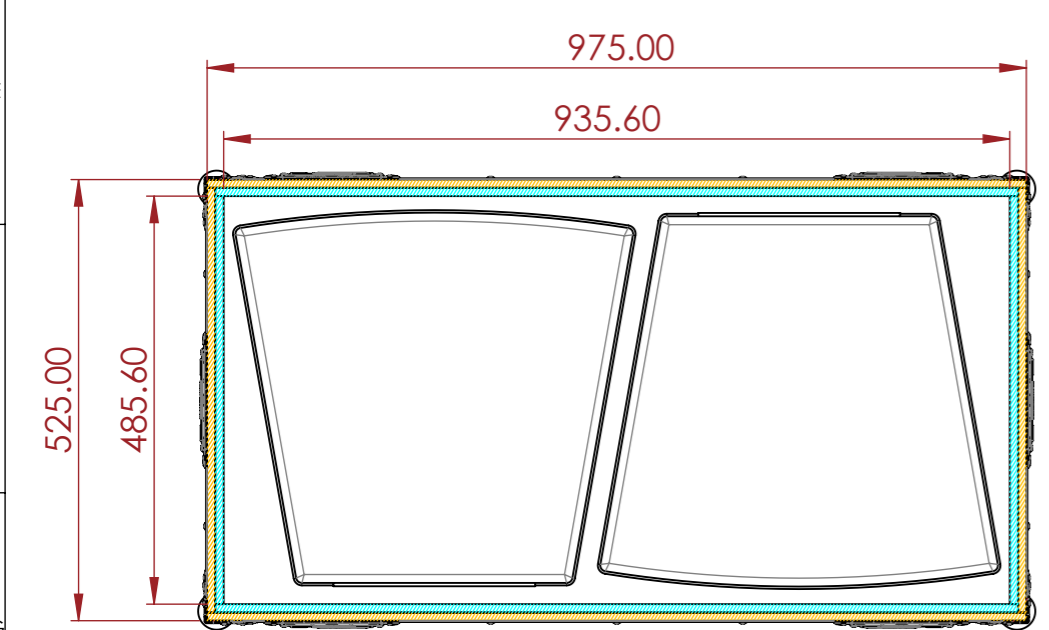

SECTION B-B

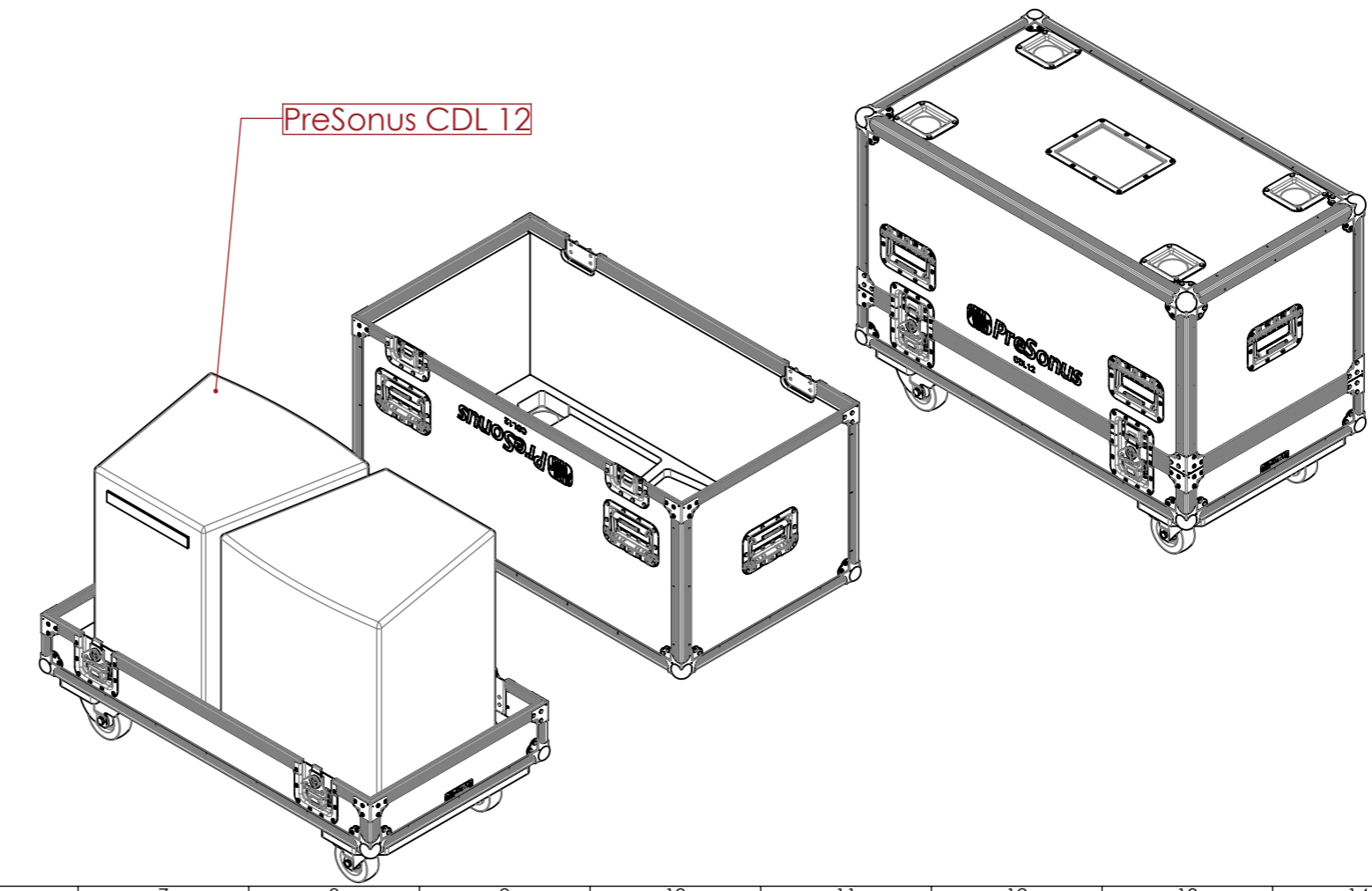

NOTES:

REV	DESCRIPTION	DATE
0	ORIGINAL ISSUE	10/31/2022

ESTIMATED WEIGHT:
34.68 KG

QUANTITY:
1

ITEM CODE:
SPK-PRESO-CD12

DRAWN BY: HA CHECKED BY: AS

SCALE:
NTS



ADD : 45/7-9 Percy St, Auburn,
NSW 2144, Australia
PH : 02 9188 6801
MAIL : sales@armorcases.com.au
WEB : www.armorcases.com.au