

NOTES:
UNLESS SPECIFIED IN THE DRAWING,
ALL PRODUCTS DISPLAYED IN THIS
DRAWING OTHER THAN THE CASE
ITSELF IS NOT PART OF OUR PRODUCT
OFFERING.

PRODUCT FEATURES

CONSTRUCTION

- 9MM BIRCH VENEER PLYWOOD WITH HPL EXTERIOR FACE AND PVC INTERIOR FACE
- ARMOR HARDWARE.

FEATURES

- 2X ERGONOMICALLY PLACED HANDLES FOR LIFTING AND TRANSPORTING
- 4X MEDIUM LATCHES
- EVA38B FOAM PROTECTION
- 2X CORNER CASTORS

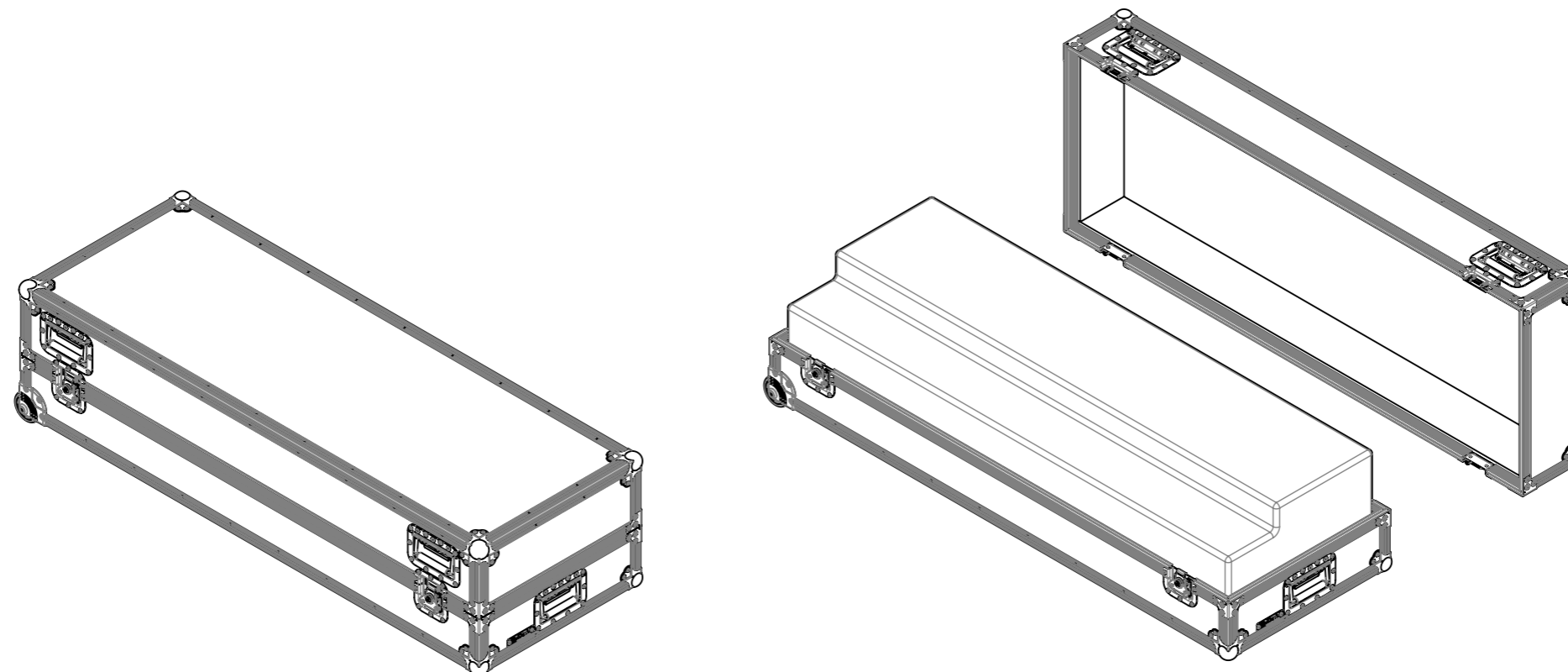

ESTIMATED WEIGHT (CASE ONLY):

31.7 KG

ITEM CODE:

KEY-KAWAI-MP11SE

DRAWN BY:

K.I

CHECKED BY:

AS

SCALE:

NTS



MAIL : sales@armorcases.com.au
WEB : www.armorcases.com.au