

## PRODUCT FEATURES

### CONSTRUCTION

- 7MM POLYPROPYLENE PLASTIC FLIGHT PANEL WITH BLACK EXTERIOR AND INTERIOR FACE
- PENN ELCOM HARDWARE

### INSTALLED EQUIPMENT (NOT INCLUDED)

- 1X OBSIDIAN NX1

### FEATURES

- REMOVABLE LID
- STORAGE SPACE UNDERNEATH THE CONSOLE
- LABEL DISH FOR EASIER IDENTIFICATION

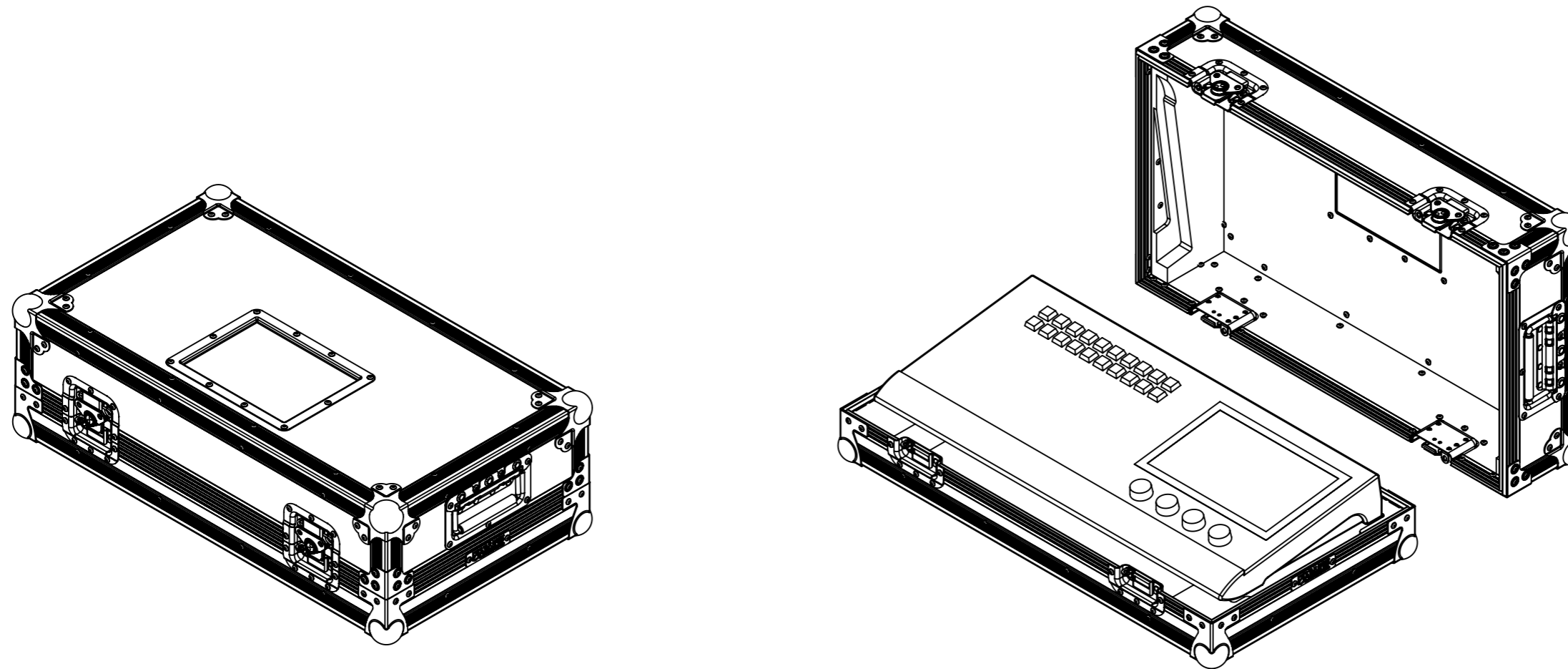
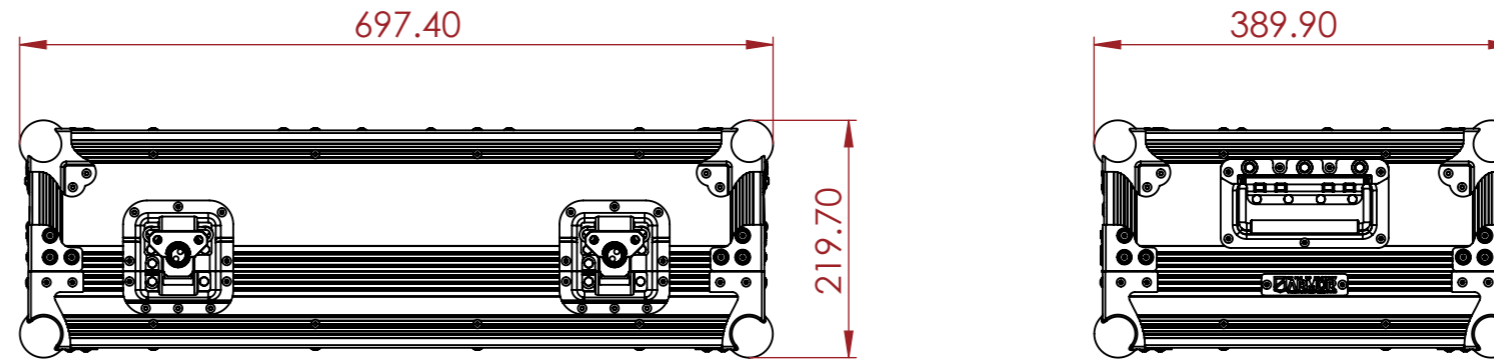

### NOTES:

UNLESS SPECIFIED IN THE DRAWING, ALL PRODUCTS DISPLAYED IN THIS DRAWING OTHER THAN THE CASE ITSELF IS NOT PART OF OUR PRODUCT OFFERING.

ESTIMATED WEIGHT (CASE ONLY):

5.7kg KG

ITEM CODE:

LXCTRL-OBS-NX1

DRAWN BY:

RP

CHECKED BY:

AS

SCALE:

NTS



MAIL : [sales@armorcases.com.au](mailto:sales@armorcases.com.au)  
WEB : [www.armorcases.com.au](http://www.armorcases.com.au)