

PRODUCT FEATURES

CONSTRUCTION

- 12MM BIRCH VENEER PLYWOOD WITH HPL EXTERIOR FACE AND PVC INTERIOR FACE
- PENN ELCOM HARDWARE
- 18MM BIRCH PLYWOOD INSERTS

INSTALLED EQUIPMENT (INCLUDED)

- TWO MONITOR VESA ATTACHMENTS FOR 24 IN AND 22 INCH MONITORS, 100 X 100 VESA MOUNTS
- 2 X PULLOUT DRAWER

FEATURES

- GAS STRUT SUPPORTED PANELS
- DUAL POCKETS LOCATED ON THE LEFT SIDE WITH 100MM WIDTH
- PULL OUT KEYBOARD DRAWER WITH FLIP OUT MOUSE PAD
- GAS STRUTS SUPPORTED TOP LID

KEY MEASUREMENTS

- WORKBENCH HEIGHT AT 920MM
- FOLDABLE TABLE TOP HEIGHT 870MM

DESIGN SPECIFICATIONS

- EXTRA POCKETS TO STORE ACCESSORIES
- UNIT NEEDS TO HAVE REAR DOOR ACCESS
- GAS STRUTS TO BE USED INSTEAD OF RATCHET LID STAYS

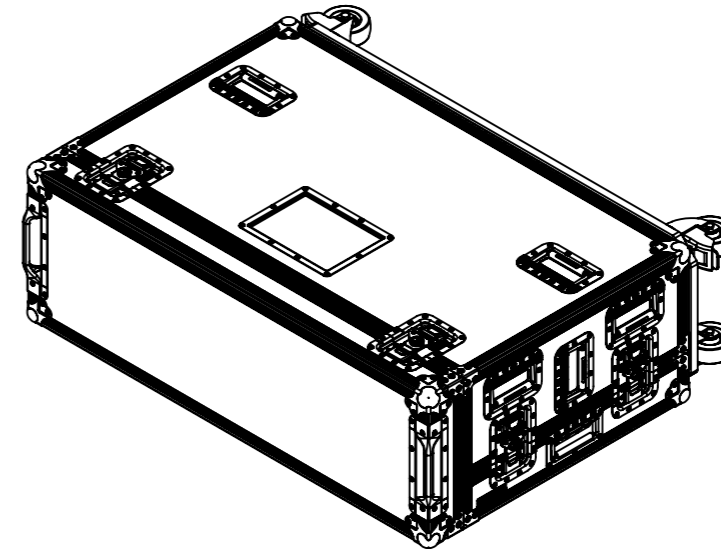
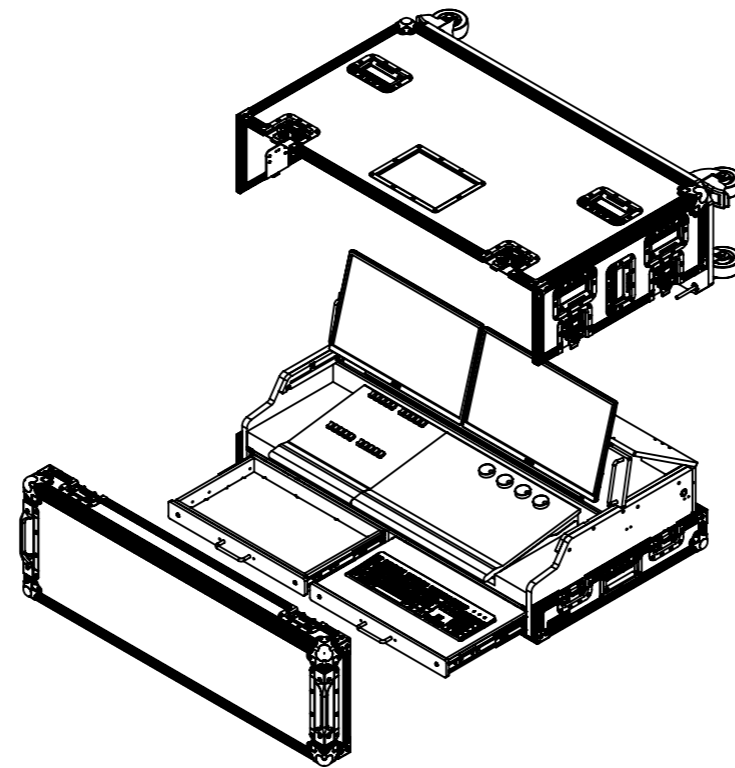
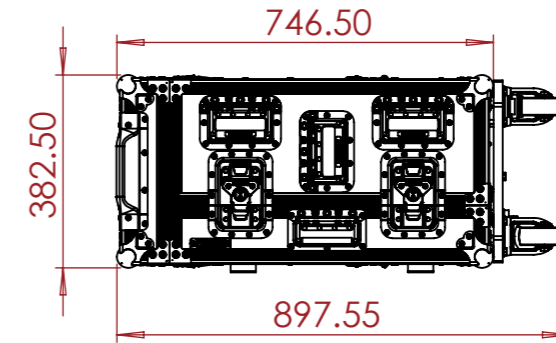
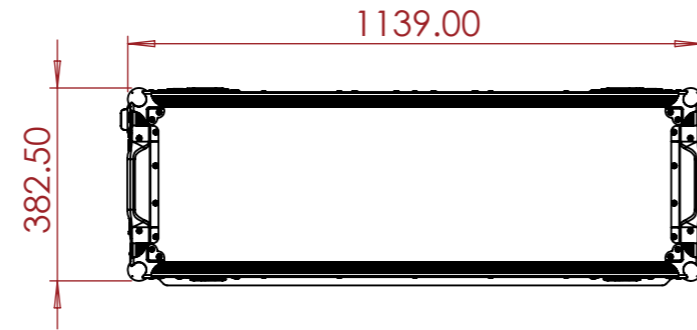

NOTES:

UNLESS SPECIFIED IN THE DRAWING, ALL PRODUCTS DISPLAYED IN THIS DRAWING OTHER THAN THE CASE ITSELF IS NOT PART OF OUR PRODUCT OFFERING.

ESTIMATED WEIGHT (CASE ONLY):

72.6kg

ITEM CODE:

LXCTRL-ETC-PWFW20

DRAWN BY:

RP

CHECKED BY:

AS

SCALE:

NTS



MAIL : sales@armorcases.com.au
WEB : www.armorcases.com.au