

PRODUCT FEATURES

CONSTRUCTION

- 12MM BIRCH VENEER PLYWOOD WITH HPL EXTERIOR FACE AND PVC INTERIOR FACE
- PENN ELCOM HARDWARE
- 18MM BIRCH PLYWOOD INSERT

INSTALLED EQUIPMENT (INCLUDED)

- ONE MONITOR VESA ATTACHMENTS FOR 24 IN MONITOR, 100 X 100 VESA MOUNTS
- 1 X PULL OUT DRAWER

FEATURES

- GAS STRUTS SUPPORTED PANELS
- PULL OUT KEYBOARD DRAWER WITH FLIP OUT MOUSE PAD
- GAS STRUTS SUPPORTED TOP LID

KEY MEASUREMENTS

- WORKBENCH HEIGHT AT 920MM
- FOLDABLE TABLE TOP HEIGHT 870MM

DESIGN SPECIFICATIONS

- EXTRA POCKETS TO STORE ACCESSORIES
- UNIT NEEDS TO HAVE REAR DOOR ACCESS
- GAS STRUTS TO BE USED INSTEAD OF RATCHET LID STAYS

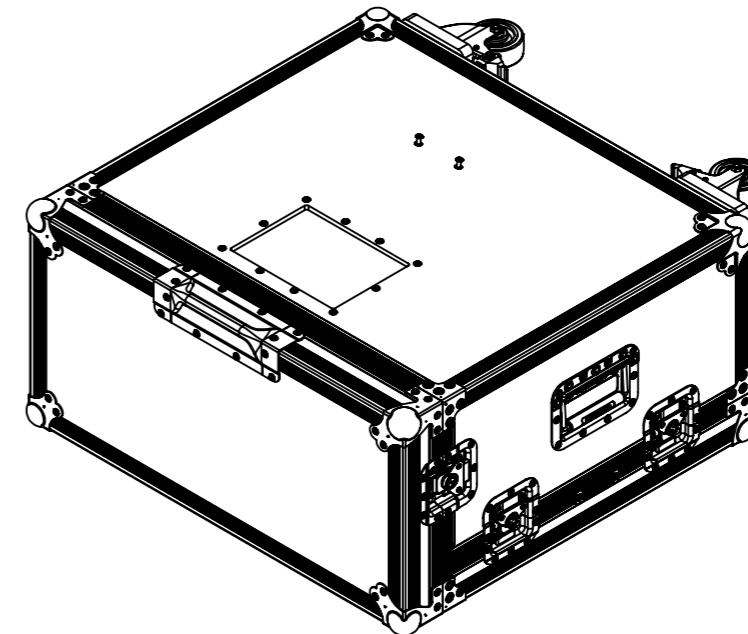
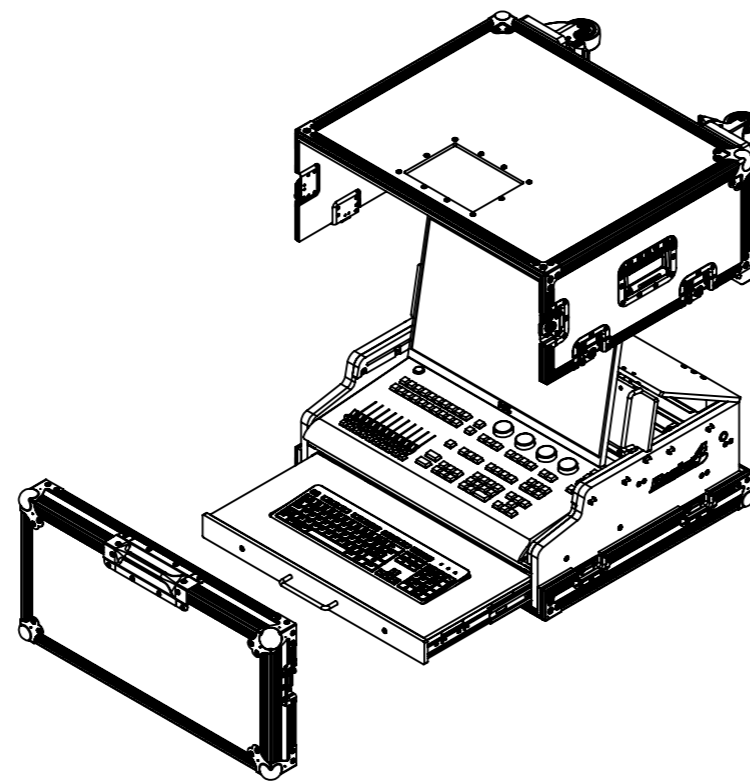
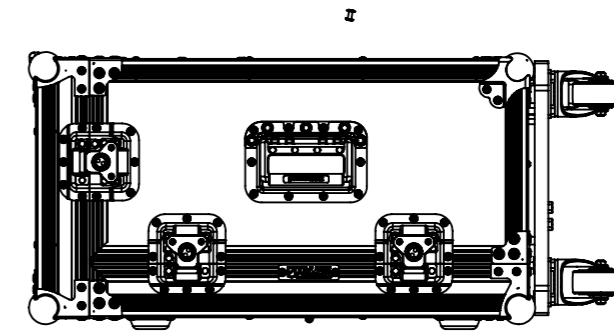
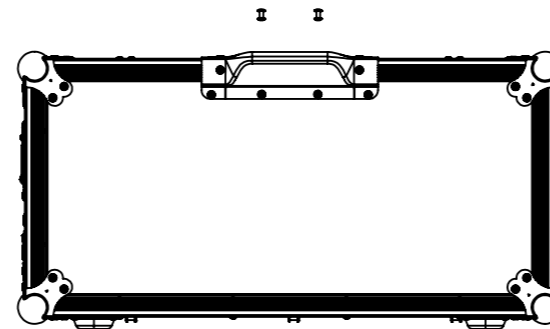

NOTES:

UNLESS SPECIFIED IN THE DRAWING, ALL PRODUCTS DISPLAYED IN THIS DRAWING OTHER THAN THE CASE ITSELF IS NOT PART OF OUR PRODUCT OFFERING.

ESTIMATED WEIGHT (CASE ONLY):

KG

ITEM CODE:

HGL4 CASE

DRAWN BY:

DS

CHECKED BY:

AS

SCALE:

NTS



MAIL : sales@armorcases.com.au
WEB : www.armorcases.com.au