

**PRODUCT FEATURES**

**CONSTRUCTION**

- 9MM BIRCH VENEER PLYWOOD WITH HPL EXTERIOR FACE AND PVC INTERIOR FACE
- PENN ELCOM HARDWARE

**INSTALLED EQUIPMENT (INCLUDED)**

- 2X VESA MOUNT(100X100/75X75) FOR SUPPORTING 24 INCH MONITORS
- LED STRIPS BELOW THE MONITORS

**INSTALLED DEVICES (NOT INCLUDED)**

- 2X DELL 2418HT 24" MONITORS
- 1X ETC ION XE 20
- 1X KEYBOARD

**FEATURES**

- DEDICATED SPACE FOR 1X ETC ION XE 20
- 1X DRAWER FOR KEYBOARD & MOUSE SETUP
- 1X DRAWER FOR GENERAL STORAGE (FOAM LINED)
- FOLDABLE MONITOR STAND THAT CAN BE TILTED IN THREE DIFFERENT ANGLES

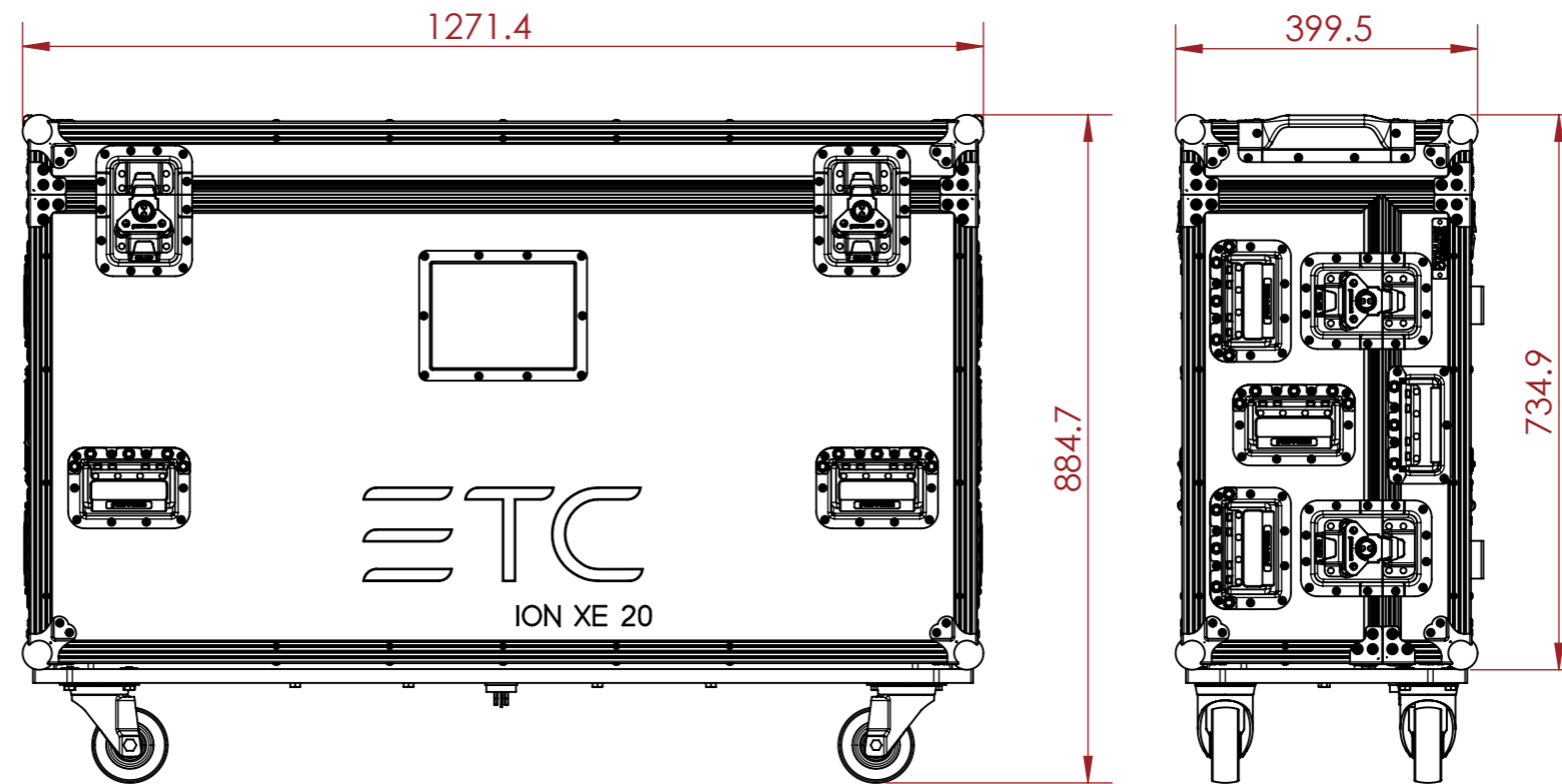

NOTES:  
UNLESS SPECIFIED IN THE DRAWING,  
ALL PRODUCTS DISPLAYED IN THIS  
DRAWING OTHER THAN THE CASE  
ITSELF IS NOT PART OF OUR PRODUCT  
OFFERING.

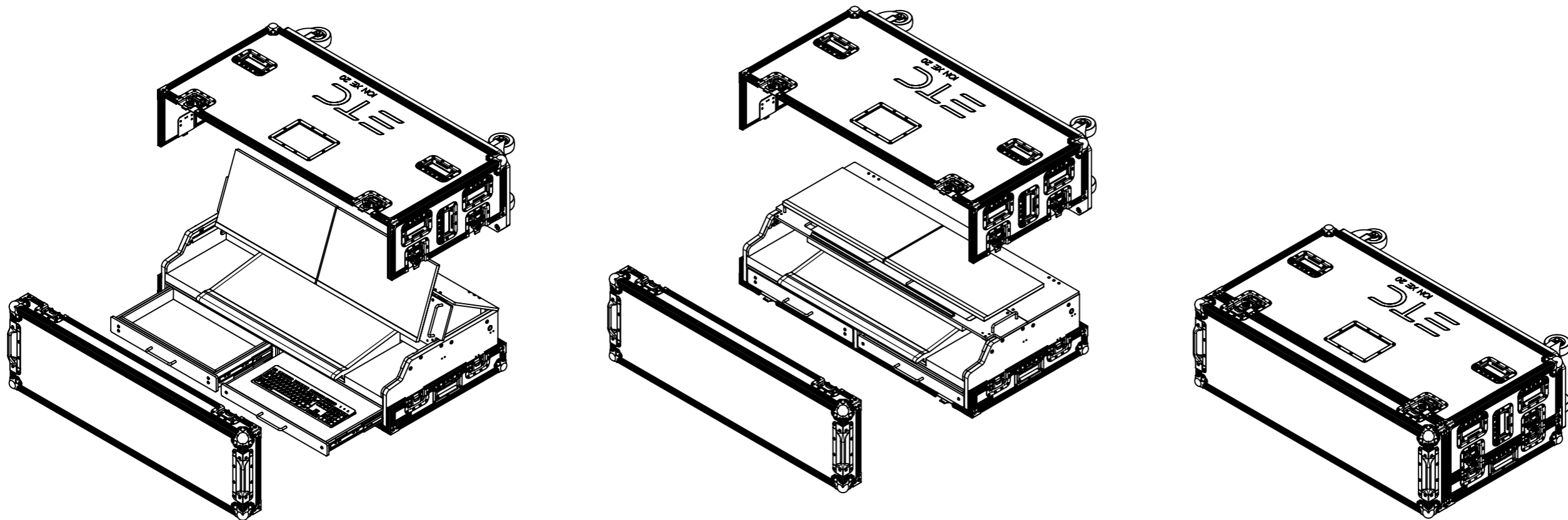

ESTIMATED WEIGHT (CASE ONLY):

76.6 KG

ITEM CODE:

LXCTRL-ETC-IONXE20

DRAWN BY:

RP

CHECKED BY:

AS

SCALE:

NTS



MAIL : [sales@armorcases.com.au](mailto:sales@armorcases.com.au)  
WEB : [www.armorcases.com.au](http://www.armorcases.com.au)