

PRODUCT FEATURES

CONSTRUCTION

- 12MM BIRCH VENEER PLYWOOD WITH HPL EXTERIOR FACE AND PVC INTERIOR FACE
- PENN ELCOM HARDWARE

INSTALLED EQUIPMENT (INCLUDED)

- 2X VESA MOUNTS(100X100/75X75) FOR 24 MONITORS MOUNTS
- 2X VESA MOUNTS(100X100/75X75) FOR 22 MONITORS MOUNTS
- 4X 9U RACK STRIPS LOCATED AT FRONT AND BACK
- 2X 3U RACK STRIPS BELOW THE MONITORS

INSTALLED EQUIPMENT (NOT INCLUDED)

- 2X DELL 2418HT 24" MONITORS
- 2X FSI BM210 21.5" MONITORS
- 1X MICROSOFT WIRED DESKTOP 600 - WIRED KEYBOARD AND MOUSE COMBO
- 2X SMART SCOPE DUO 4K

FEATURES

- FRONT LID CAN BE SETUP AS TABLE FOR ADDITIONAL WORKSPACE
- SLAM LID AND HATCH DOOR LOCATED AT THE BACK
- PULL OUT PLATFORM THAT CAN BE LOCKED AT MINIMUM AND MAXIMUM LENGTH
- FOLDABLE MONITOR SUPPORT
- GAS STRUT SUPPORTED LID
- FOAM SHOCK PROOF RACK BAYS

KEY MEASUREMENTS

- PLATFORM HEIGHT AT 802MM
- FOLDABLE TABLE TOP HEIGHT - 800MM
- FRONT AND REAR RACK STRIPS DISTANCE 478.6MM
- REAR RACK STRIPS TO REAR PANEL 50MM
- STORAGE INTERNAL DIMENSIONS : 135X579X245MM(WDXH)
- MAIN MONITOR AREA – MAXIMUM ALLOWABLE DIMENSIONS: 560X340X55 MM (WDXH)
- FOLD-OUT MONITOR AREA – MAXIMUM ALLOWABLE DIMENSIONS: 540X340X55 MM (WDXH)

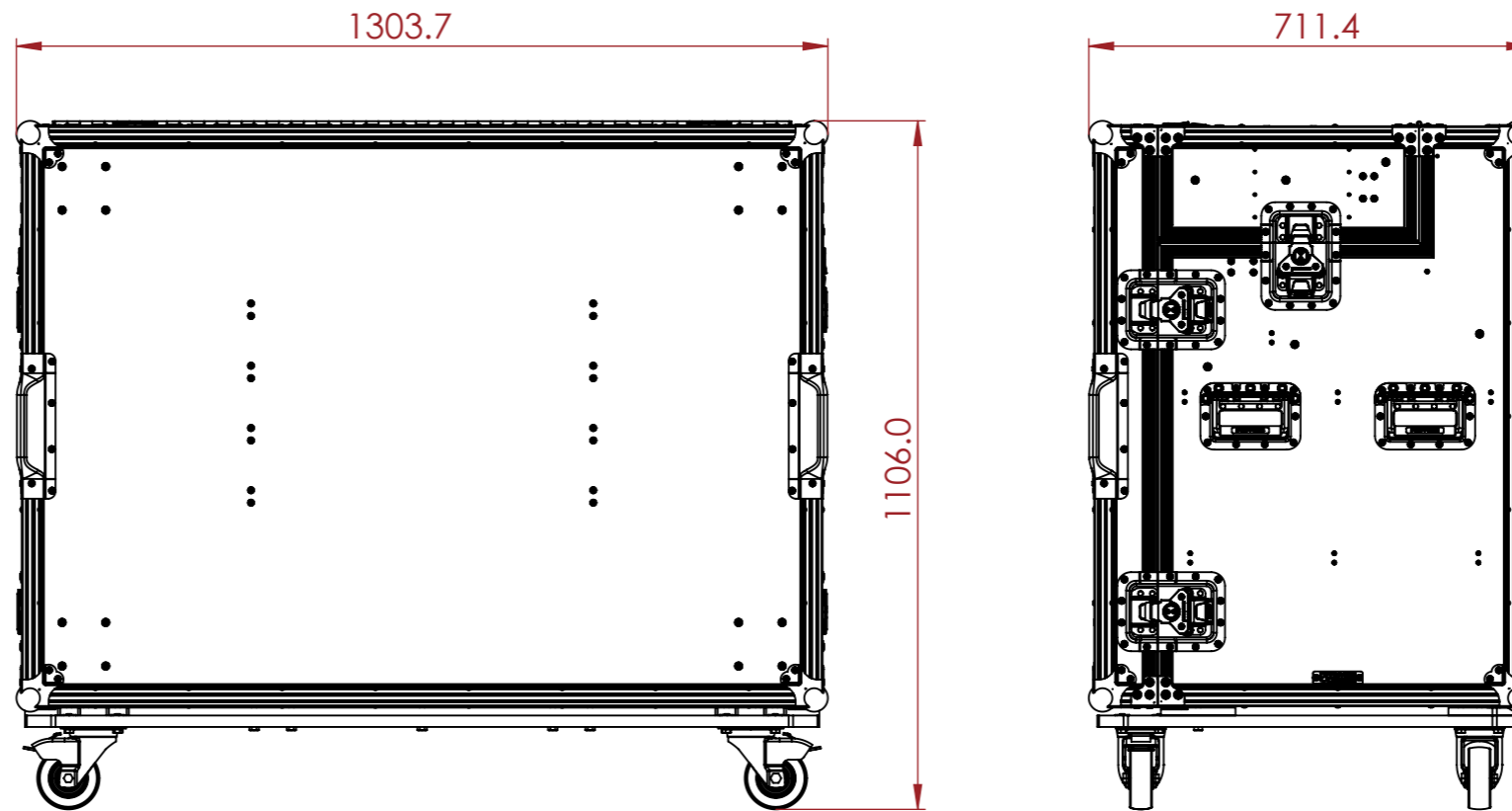

NOTES:  
UNLESS SPECIFIED IN THE DRAWING,  
ALL PRODUCTS DISPLAYED IN THIS  
DRAWING OTHER THAN THE CASE  
ITSELF IS NOT PART OF OUR PRODUCT  
OFFERING.

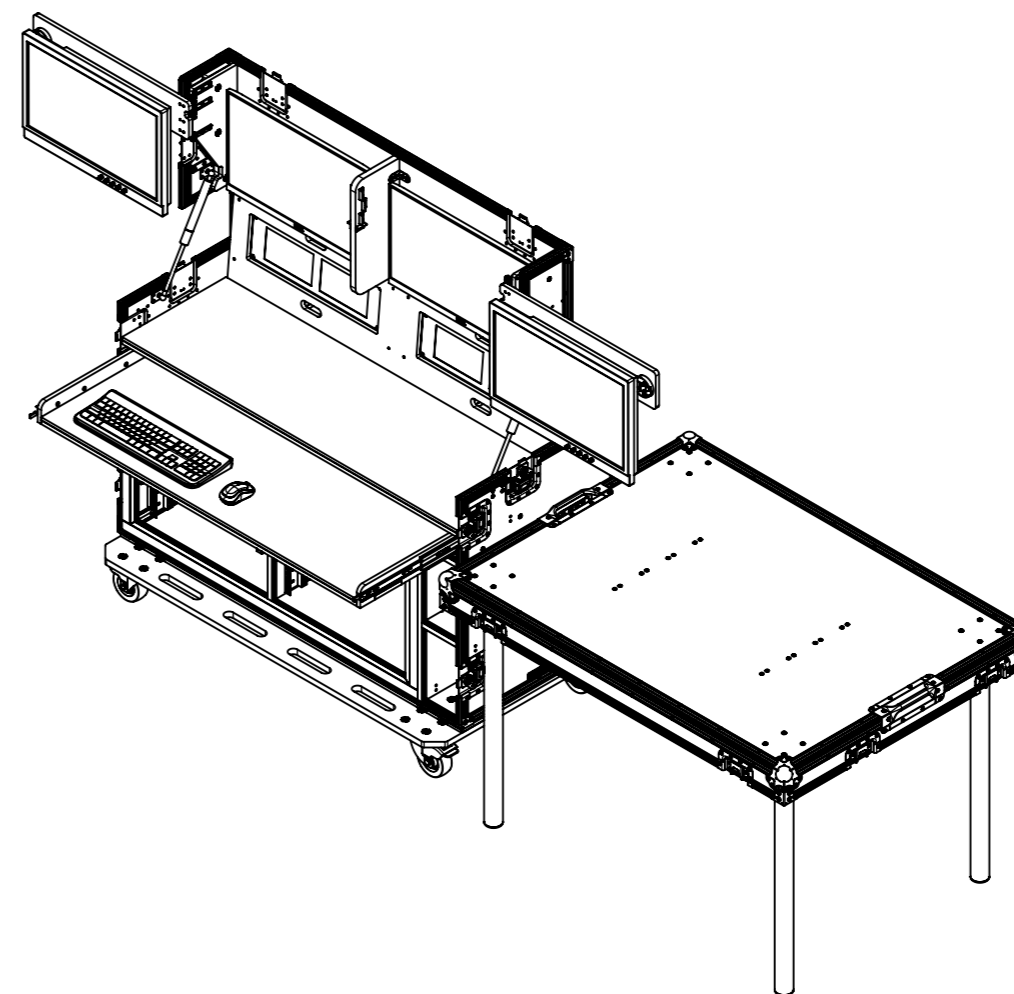
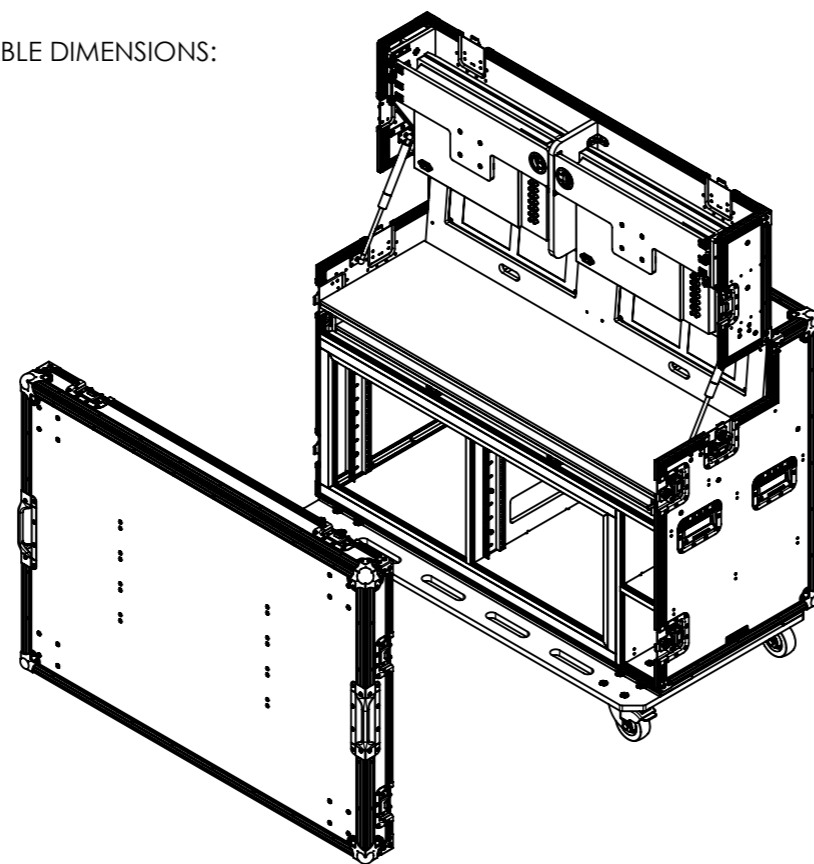
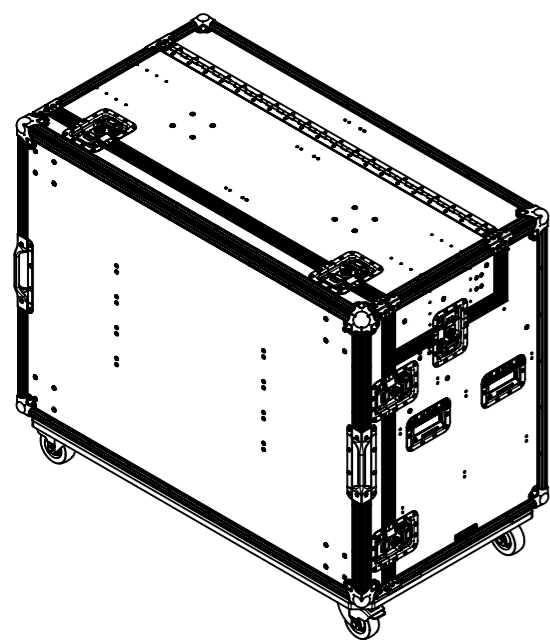

ESTIMATED WEIGHT (CASE ONLY):

151.77 KG

ITEM CODE:

WS-FP2

DRAWN BY:

RP

CHECKED BY:

AS

SCALE:

NTS



MAIL : [sales@armorcases.com.au](mailto:sales@armorcases.com.au)  
WEB : [www.armorcases.com.au](http://www.armorcases.com.au)