

PRODUCT FEATURES

CONSTRUCTION

- 12MM BIRCH VENEER PLYWOOD WITH HPL EXTERIOR FACE AND PVC INTERIOR FACE
- PENN ELCOM HARDWARE

INSTALLED EQUIPMENT (INCLUDED)

- TWO MONITOR VESA ATTACHMENTS FOR 24 INCH AND 21 INCH MONITORS, 100 X 100 VESA MOUNTS
- 11RU RACK STRIPS LOCATED AT THE FRONT AND BACK
- FRONT TO BACK RACK STRIP DISTANCE AT 516MM
- 1X 2RU TRAY
- 2X 2RU DRAWER
- 2X 1RU PATCH PANEL
- 1X 6 WAY PDU AT REAR

FEATURES

- FRONT LID CAN BE SETUP ON THE RIGHT OR LEFT SIDE OF THE WORKSTATION
- SLAM LID LOCATED ON THE BACK
- PULL OUT KEYBOARD DRAWER WITH FLIP OUT MOUSE PAD
- FLIP OUT SECOND MONITOR

KEY MEASUREMENTS

- FOLDABLE TABLE TOP HEIGHT 894MM
- TOP PLATFORM HEIGHT 940MM

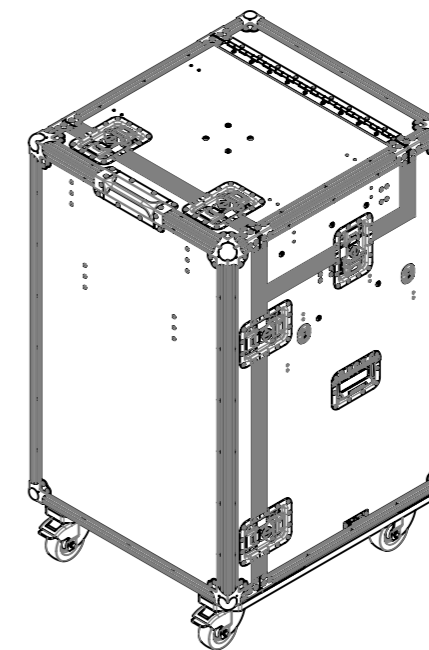
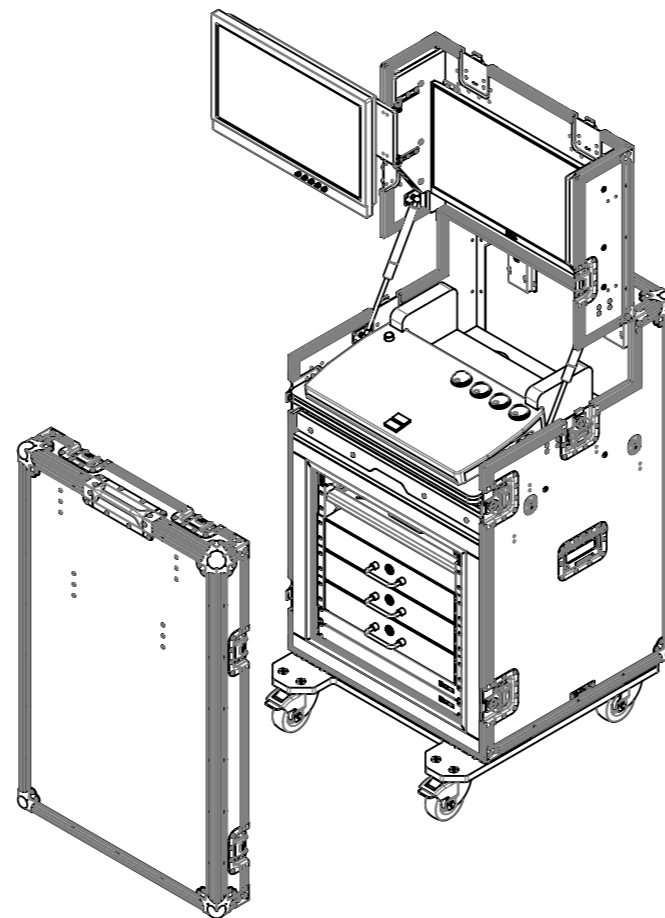
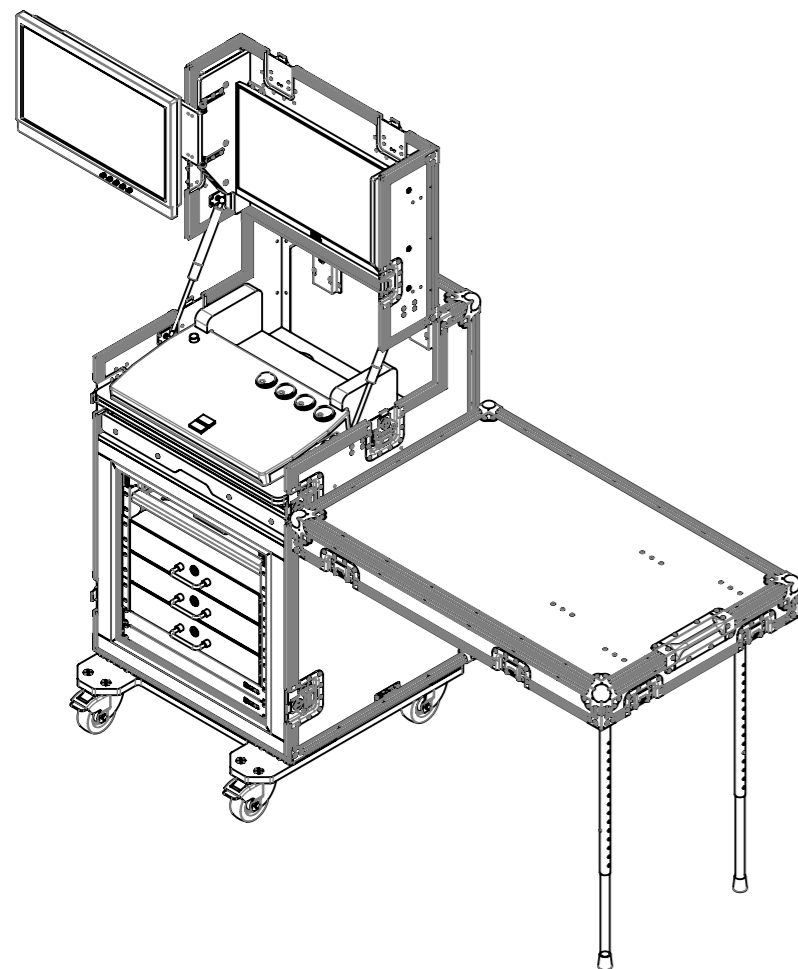
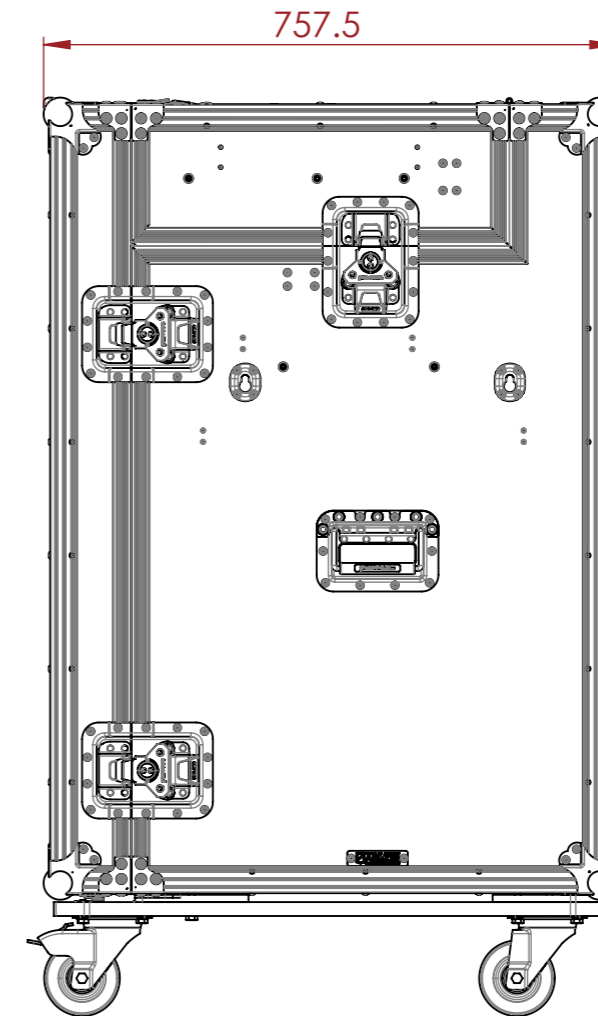
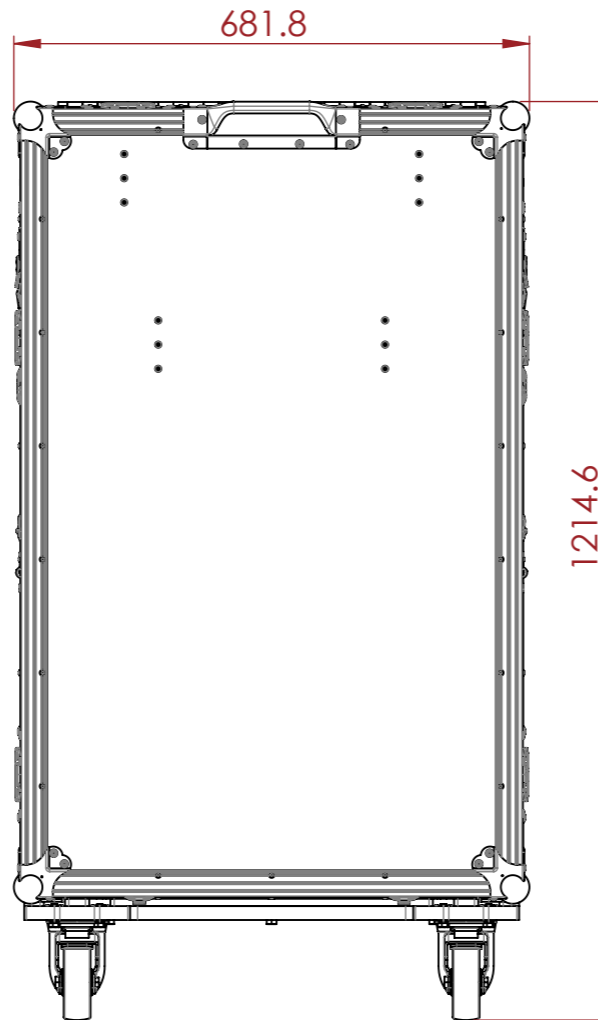

NOTES:

UNLESS SPECIFIED IN THE DRAWING, ALL PRODUCTS DISPLAYED IN THIS DRAWING OTHER THAN THE CASE ITSELF IS NOT PART OF OUR PRODUCT OFFERING.

ESTIMATED WEIGHT (CASE ONLY):

114.71 KG

ITEM CODE:

WS-FP1-NXW

DRAWN BY:

HA

CHECKED BY:

AS

SCALE:

NTS



MAIL : sales@armorcases.com.au
 WEB : www.armorcases.com.au